

## Learning systems for driving instructors

This publication provides a recognised national industry standard for driver education in New Zealand.



# Learning systems for driving instructors

© NZ Transport Agency

[www.nzta.govt.nz](http://www.nzta.govt.nz)

July 2010

ISBN: 978-0-478-36451-4 (online)

## Acknowledgements

The NZ Transport Agency (NZTA) acknowledges the assistance of the following organisations in the development of this manual:

Tranzqual ITO

Roadtrain (NZ) Ltd.

## Copyright information

This publication is copyright © NZ Transport Agency. Material in it may be reproduced for personal or in-house use without formal permission or charge, provided suitable acknowledgement is made to this publication and the NZ Transport Agency as the source. Requests and enquiries about the reproduction of material in this publication for any other purpose should be made to:

Manager, Information  
NZ Transport Agency  
Private Bag 6995  
Wellington 6141

The permission to reproduce material in this publication does not extend to any material for which the copyright is identified as being held by a third party. Authorisation to reproduce material belonging to a third party must be obtained from the copyright holder(s) concerned.

## Disclaimer

The NZ Transport Agency has endeavoured to ensure material in this document is technically accurate and reflects legal requirements. However, the document does not override governing legislation. The NZ Transport Agency does not accept liability for any consequences arising from the use of this document. If the user of this document is unsure whether the material is correct, they should refer directly to the relevant legislation and contact the NZ Transport Agency.

## More information ...

NZ Transport Agency  
Published July 2010

ISBN: 978-0-478-36451-4 (online)

If you have further queries, call our contact centre on 0800 699 000 or write to us:

NZ Transport Agency  
Private Bag 6995  
Wellington 6141

This document is available on the NZ Transport Agency's website at [www.nzta.govt.nz](http://www.nzta.govt.nz).



## Record of amendment

Amendment number	Page number	Description of change	Effective date
		11	

# Contents

Introduction	1
Motor vehicles able to be driven on a class 1 driver licence	4
Definitions	4
About driving instructor (I) endorsements	5
Responsibilities and attributes of a driving instructor	5
Section 1: The car and the road	7
Automobile technology and handling characteristics	7
The engine	7
The transmission (gearbox)	7
The differential and traction control	8
Drive wheel configuration	8
The braking system and ABS	9
Electronic stability control	
Power steering	10
Tyres	10
Wheel balancing and alignment	10
Space saver wheels	11
Suspension system	12
Automobile dynamics	13
Gravity and mass	13
Centre of gravity and weight transfer	14
Friction	14
Velocity and speed	14
Kinetic energy	15
Centrifugal force	16
Under-steer and over-steer	16
Braking	17
Acceleration	18
Cornering	18
Driving emergencies	19
Section 2: How people learn	21
The experiential learning process	25
Characteristics of adult learners	25
Characteristics of a good coach, mentor and facilitator	25
Learning systems for driving instructors	26

Establishing a climate for learning	27
Learning concepts	27
The sensory system	28
Visual	28
Auditory	28
Kinaesthetic	29
Perception	29
Memory	29
Remembering and forgetting	30
Summary of the learning process	30
The driver training learning process	31
Rote learning	31
Gestalt learning	32
The roles of rote and gestalt in driver training	32
Transfer of learning	32
Types of learning performances	33
Discrimination	33
Problem definition and problem solving	34
Recall	34
Manipulation	34
Speech	35
Summary	35
Factors affecting learning	36
Internal factors	36
External factors	37
Communication	37
The objectives of communication	37
Non-verbal communication	38
Barriers to communication	39
Overcoming barriers to interpersonal communication	40
The context or situation	41
Effective communication	42
Communication and the learner's needs	43
Presenting learning events	43
Group learning	44
Learning aids	46
Section 3: Analysing training needs/driving assessment/training objectives	49
Analysing training needs	49

Driving assessment	49
Assessment route	49
The assessment report	50
Driving assessment form	51
Definition of terms	52
The seven driving manoeuvres	52
Skills assessed	52
Conducting the assessment	54
Making decisions and judgements	55
Marking the assessment sheet	55
Analysing the assessment sheet	59
Identifying patterns	59
Analysing fault patterns	61
Self-check exercise	61
Writing training objectives	63
Section 4: Conducting practical instruction	65
Managing learning	65
Empowering parents and supervisors	67
Develop a training plan	67
Select and prepare suitable learning material	67
Organise progressive units of learning	67
Develop individual lesson plans	68
Grade skills and techniques	68
Route planning	68
Beginner routes	69
Intermediate routes	69
Advanced routes	69
Graduated tuition	70
Active involvement	70
Reinforcing learning	71
Reduce the likelihood of over-confidence	71
The sequence of training	71
Basic training	72
Developing the skill	73
Independence	74
Terminology and instructions for use with trainee drivers	74
Basic terminology	74
Giving instructions	76

Specific instructions	77
Crisis management	77
Intervention and safety	77
Verbal intervention	78
Physical intervention	78
Driving school crashes	80
Evaluating competency	80
Criterion-referenced assessment	81
Principles of feedback	81
Summary of the learning process	82
The first driving lesson	83
Subsequent lessons	85
Drivers approaching driving test standard	86
Driving test standards	87
Section 5: Hazard identification and risk reduction	88
Perception	88
Anticipation	88
Hazard recognition	88
The six driving conditions	89
The seven driving manoeuvres	89
The six crash positions	92
Observation techniques	94
Aim high	95
Get the big picture	96
Keep the eyes moving	97
Leave yourself an 'out'	99
Make sure other road users see you	100
The hazard action plan	101
The system of vehicle control	102
Blind zones and view blockers	102
Gap selection	105
Distractions	107
Road craft	107
Section 6: Individual lesson plans (car)	109
Introduction	109
Layout	109
Individual training record	111
Lesson plans	116

1 Pre-driving checks	116
2 Cabin drills	122
3 Moving off and stopping – straight ahead	126
4 Steering	130
5 Moving off and stopping – at an angle	133
6 Signals	137
7 Basic gear changing	140
8 Automatic transmission	144
9 Hazards and the system of vehicle control	147
10 Intersection techniques	152
11 Cornering	160
12 Moving off – uphill and downhill	164
13 Negotiating steep grades	168
14 Overtaking and use of passing lanes	172
15 Town driving	177
16 Motorway driving	182
17 Rural/open road driving	187
18 Night driving	194
19 Reversing	198
20 Emergency stops	204
21 Parallel parking	208
22 U-turns and three-point turns	212
Section 7: Blank road layouts	216

---

# Introduction

This manual has been revised to provide a recognised national industry standard in supporting the NZQA-based driver educator qualifications, the NZ Transport Agency (NZTA) approved driving Instructor course and to assist both instructors and company driver trainers in the preparation and delivery of programmes designed to improve driving standards and reduce driving risk. The original document was written after consultation with many experienced driving instructors, both in New Zealand and overseas, who gave freely of their knowledge and expertise and this second edition has maintained the core information of that earlier publication but has been updated to reflect changes in technology and instructional practices, and to support the unit standard-based assessments that drive both road transport industry training and a large part of the driver licensing regime.

Each section of the manual is complementary to all the others.

The first section, The car and the road, discusses automobile dynamics, light motor vehicle components and systems, and driving emergencies.

The second section, How people learn, considers the learning process, factors that influence the way people learn, teaching techniques and communication issues.

The third section, Analysing training needs/advanced driving assessment/training objectives, deals with analysing training needs to complement each individual trainees level of competency, conducting driving assessments and writing training objectives.

The fourth section, Conducting practical instruction, covers the principles of delivering practical driving instruction. This includes topics such as route planning, instructional techniques, issuing instructions, development of training plans, verbal and physical intervention and managing learning.

The fifth section, Hazard identification and risk reduction, deals with the training and implementation of hazard identification and driver intervention to minimise or eliminate risk.

The sixth and final section, Individual lesson plans, outlines the task descriptions for the psychomotor skills necessary to drive a car. Each lesson plan includes training objectives (which can be used in the development of individual training plans) and common driver faults. Space has been provided for additional information to be added by the instructor to reflect individual needs and performance.

The manual provides valuable information for the following NZQA unit standards:

- US14521 Observe and analyse a person's driving and determine optimal ways to achieve required performance.
- US14523 Carry out in-vehicle driver training.
- US16646 Develop and manage individual driver training plans.
- US16647 Describe factors that affect people's learning in a driver training environment and describe methods to manage these.
- US20179 Describe light motor vehicle components, components, dynamics and handling characteristics.
- US20180 Demonstrate knowledge of hazard detection and responses.
- US25717 Demonstrate knowledge of, and apply, effective decision making processes for enhanced driver safety.

Driving is now accepted as a life skill – one that is seen as being necessary in both social and vocational contexts. As a result, trainees can be young and inexperienced, seeking the skills and knowledge to achieve a driver licence or they could be drivers with varying degrees of experience and ability who are upskilling, perhaps to different classes of driver licences, attending company sponsored fleet training courses and assessments or have been ordered to complete training by the courts as a result of traffic offences.

In addition to these, many companies utilise inhouse trainers to monitor and assess driver performance, particularly in the road transport industry, and this manual, we hope, will provide valuable information for these trainers. While much of the focus is on light vehicle driver instruction, most of the information also has relevance to heavy vehicle training. When providing heavy vehicle training, this manual should be read in conjunction with the supplementary manual *Learning systems for driving instructors: heavy motor vehicles*, which is also available on the NZ Transport Agency website. For further information relating to heavy motor vehicle systems and components, dynamics and driving techniques, driving instructors and trainees should refer to the MITO publication *Professional skills for driving trucks* available from [www.mito.org.nz](http://www.mito.org.nz).

## Graduated driver licensing system (GDLS) class 1

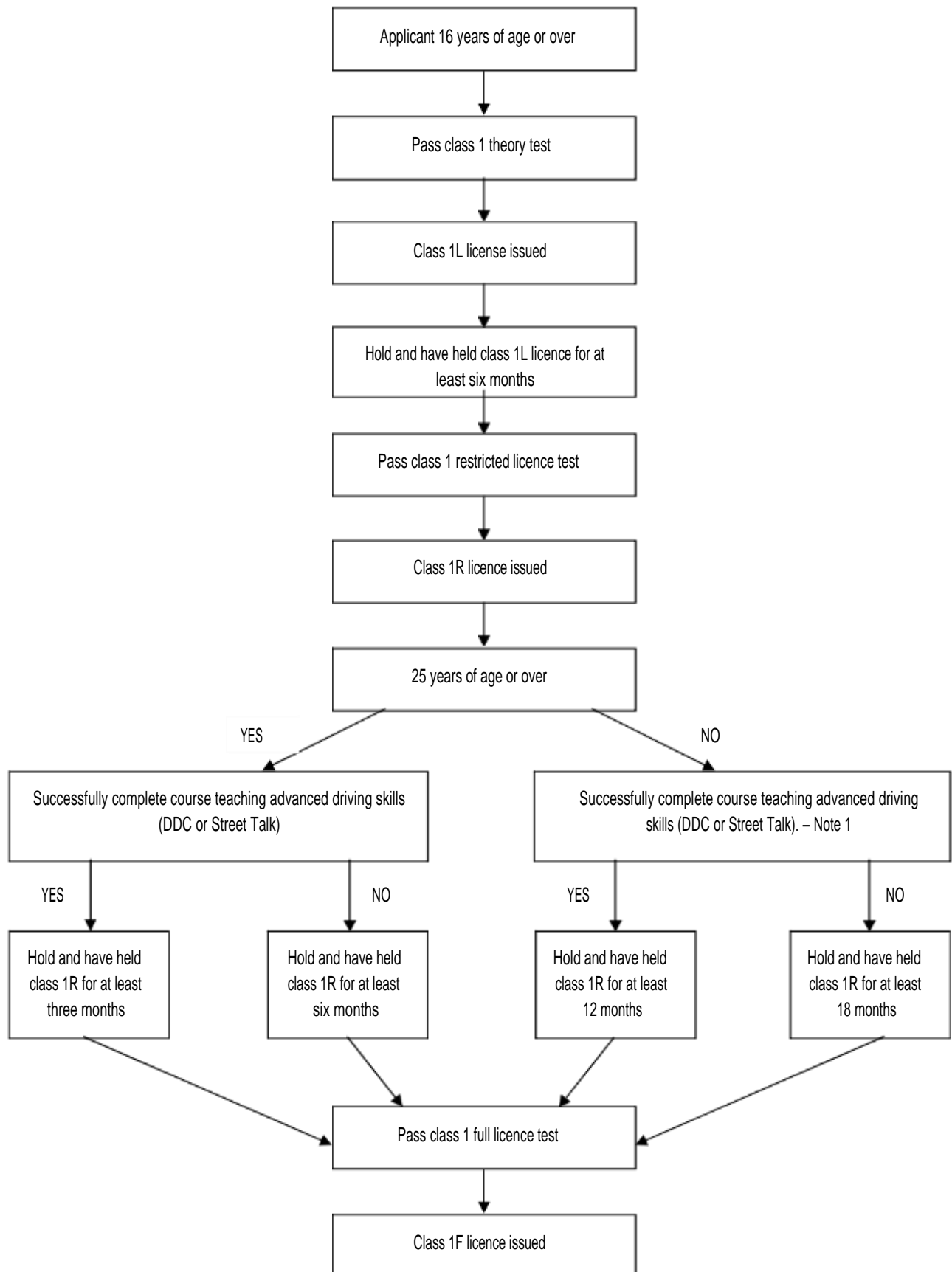

Note 1: Course must be undertaken at least six months after the applicant's restricted licence was issued.

# Motor vehicles able to be driven on a class 1 driver licence

## Class 1L or 1R

- A motor vehicle (including a tractor or combination vehicle but excluding a motorcycle) that has a gross laden weight of not more than 4500kg, or a combination vehicle that has a gross combined weight of not more than 4500kg.
- A motorhome or tradesperson's vehicle with a GLW of not more than 6000kg, provided its on-road weight does not exceed 4500kg.
- A moped or all-terrain vehicle.

## Class 1R can also drive:

- An agricultural tractor that has a GLW of not more than 18,000kg, or a combination vehicle (consisting of an agricultural tractor and agricultural trailer) that has a GCW of not more than 25,000kg, if driven at a speed not exceeding 40km/h.

## Class 1F can drive:

- A vehicle that has a GLW or GCW of no more than 6000 kg (this includes tractors and combination vehicles, but does not include motorcycles).
- A moped or all-terrain vehicle
- Any motorhome or tradesperson's vehicle with a GLW of not more than 6,000 kg
- A combination vehicle of not more than 6000kg which is not a tractor/trailer or agricultural tractor/trailer
- A forklift with a GLW of not more than 18,000kg
- A special-type vehicle that runs on wheels and has a GLW of not more than 6000 kg
- A special-type vehicle that runs on rollers or self-laying tracks and has a GLW of not more than 18000 kg
- A special type vehicle that runs on wheels and has a GLW of more than 6000kg but not more than 18,000 kg, if driven at a speed not exceeding:
  - 40 km/h, in the case of a special-type vehicle that is an agricultural motor vehicle; or
  - 30 km/h, in the case of any other special type vehicle
- A tractor with a GLW of more than 6000 kg but not more than 18,000 kg, if driven at a speed not exceeding:
  - 40 km/h, in the case of an agricultural tractor
  - 30 km/h, in the case of any tractor
- A combination vehicle with a GCW of more than 25000 kg if driven at a speed not exceeding:
  - 40 km/h in the case of an agricultural tractor towing an agricultural trailer
  - 30 km/h in the case of any other tractor towing a trailer, if it is being used in non-agricultural land management operations.
- an agricultural tractor with a GLW of more than 6000 kg but not more than 18,000kg, or a combination vehicle (consisting of an agricultural tractor and agricultural trailer) with a GCW of not more than 25000 kg, if the driver holds a special-type vehicle endorsement.

---

# Definitions

Mobile home means a motor vehicle permanently fitted for accommodation by the inclusion of sleeping and cooking facilities with more than half of the vehicle floor area (including the floor area of both the tractor and trailer if a combination vehicle) fitted out for accommodation.

Tradesperson's vehicle means a motor vehicle whose body is designed or adapted for use principally by tradespersons to carry special purpose trade equipment or trade goods (excluding general freight)

Special-type vehicle means any motor vehicle that:

- a. is a forklift, or
- b. runs on rollers, or
- c. runs on:
  - i. self-laying tracks, or
  - ii. wheels, but is not a passenger vehicle, a trade vehicle, a tractor, a fire engine, or a vehicle recovery service vehicle.

Tractor means a motor vehicle (other than a traction engine) constructed principally for towing an agricultural trailer or powering agricultural implements

Notes: The information on this page was correct at the time of publication but is subject to change from time to time. Please refer to schedule 3 of the Land Transport (Driver Licensing) Rule 1999 to confirm current requirements. The rule is available for viewing on the NZTA website at: [www.nzta.govt.nz/resources/rules/driver-licensing-1999-index.html](http://www.nzta.govt.nz/resources/rules/driver-licensing-1999-index.html)

## About driving instructor (I) endorsements

- Clause 22 of the Land Transport (Driver Licensing) Rule 1999 requires the following persons to hold a driving instructor endorsement on their driver licence –  
‘A person who, for financial or commercial gain, provides instruction on a road in driving a motor vehicle must hold a driving instructor endorsement for those classes of licence that relate to the motor vehicles for which the person intends to provide instruction.’
- The driving instructor endorsement is specific to the class of vehicle in which you may provide instruction. The full range of driving instructor endorsements are I1, I2, I3, I4, I5, I6. For example if you wish to teach in a class 4 vehicle you must hold a current I4 endorsement on your driver licence.
  - Once you have obtained a driving instructor endorsement it will be valid for either one or five years (depending on the period of time you applied for). The expiry date of the ‘I’ endorsement will appear on the back of your driver licence. You must also ensure that your base licence is current at all times (expiry date of your base licence is the date shown under 4b on the front of your driver licence). Note that the expiry date of the ‘I’ endorsement will be different from the expiry date of your base licence.
- If the address details provided to the NZTA are correct (current), you will be sent a reminder notice before your driving instructor endorsement is due to expire. The renewal process can be completed at any approved NZTA driver licensing agent. You may elect whether you wish to renew your endorsement for either one or five years. When renewing please remember that you may not provide instruction unless you have a current endorsement on your driver licence, so please allow at least eight weeks for the process to be completed and a new licence to be received in the mail. Remember that it is your responsibility to ensure that your endorsement (and base driver licence) remain current.
- If you do not wish to renew your driving instructor endorsement you may let it lapse (expire) for up to five years. This means that during this time you may renew the endorsement via the normal renewal process, but once it has been expired for five years or more you will be required to apply as a new applicant and satisfy all requirements (including completing the ‘I’ endorsement course).

## Responsibilities and attributes of a driving instructor

Driving instructors are critical to the driver education process as they offer a source of professional instruction and therefore provide a means of improving driving standards across the board for both new and experienced drivers.

In delivering professional instruction all approved driving instructors must comply with the standards set by the NZTA. This manual, together with the relevant legislative requirements, form the basis of the standards required by the NZTA.

As an approved driving instructor you are required to:

- have a thorough working knowledge of appropriate driving practices (in relation to best practice and legislative requirements), driver licensing requirements including progression requirements for the graduated driver licensing system. Refer to flowchart on page 1 for GDLS progression to a class 1 full driver licence
- have a good working knowledge of general mechanical principles and vehicle technology and dynamics
- be able to demonstrate professional personal driving skills and techniques
- have the desire and patience to pass on those attributes to their trainees
- comply with the NZTA requirement that there must be no physical contact with students during the delivery of driving instruction. The only possible exceptions to this requirement would be when engaging in normal acceptable forms of greetings or farewells (eg a handshake) and in an emergency situation where an

instructor is required to take control of the vehicle to preserve safety and the resulting contact was unavoidable

- be sensitive to issues relating to culture, gender, sexual orientation, religion etc
- apply discretion in relation to information pertaining to trainees and understand the effects and provisions of the Privacy Act
- ensure that the safety and well-being of your trainees and the general public is paramount at all times
- display professionalism in all aspects of driver training and assessment
- project an image that reflects positively upon the driver training industry
- have a culture of continuous quality improvement. This includes having systems of regular course and instructional evaluation
- provide trainees with a safe and positive learning environment that is free from unnecessary distractions. This includes turning off any cell phones for the duration of practical driving instruction
- continue to meet NZTA requirements in being a fit and proper person to hold approval as a driving instructor (I endorsement). Any substantiated complaints, traffic or criminal offending may result in a review (and possible revocation) of this approval
- retain records of any driving instruction provided for at least 12 months
- ensure that any practical driving instruction is carried out in a vehicle that meets all relevant legal requirements and is maintained to warrant of fitness standard at all times (or certificate of fitness if appropriate). This includes the display of L plates for learner licence holders unless the vehicle used is clearly marked as being used for driving instruction
- ensure that any person receiving practical driving instruction holds and carries an appropriate and current driver licence
- comply with any requirements made in writing by the NZTA.

## Section 1: The car and the road

### Automobile technology and handling characteristics

The predecessors of the modern car were the horse-drawn carriage and the bicycle. It is doubtful that the 19<sup>th</sup> century pioneers of the car could have envisaged that their invention would lead to the highly sophisticated, efficient, high speed vehicles of today. The car developed from a whimsical plaything for the rich into an essential element of everyday life. It represents independence and mobility and it has reshaped society worldwide in a relatively short space of time.

While automotive technology races ahead in leaps and bounds, the basics of those first cars haven't changed much at all. A car still has a body, four wheels, a suspension system, an engine and a transmission. While most of the components on a modern car are much more advanced, more reliable and more efficient than they once were, the driver's ability to work on the vehicle and affect repairs has diminished somewhat with the introduction of electronic control systems. The basic principles and purposes of those components, however, haven't changed much at all.

The following information is quite basic and serves as an introduction to the major components and systems of a motor vehicle and, more importantly, their effects on vehicle handling and performance, something that driving instructors must consider and include into training. Readers are encouraged to keep themselves up to date with current technology and to refer to other publications and to the internet for more detailed explanations. Websites like [www.howstuffworks.com](http://www.howstuffworks.com) offer a wide range of information that can be used to support driver instruction.

#### The engine

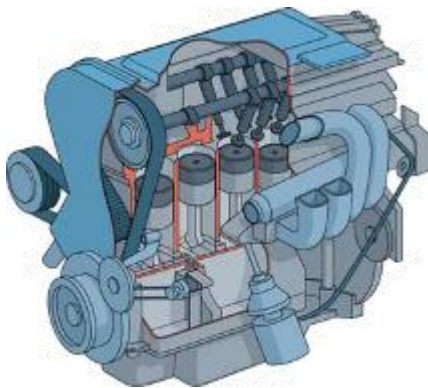

The engine provides the power necessary to turn the road wheels of the vehicle. It converts chemical energy or, more recently, electrical energy into mechanical energy. The power produced by an engine reflects its ability to do work and is measured as horsepower or kilowatts. There is a direct relationship between this power and the vehicle weight that influences vehicle performance. The greater the power output and the lighter the vehicle, the greater the performance characteristics of the vehicle will be.

Torque is the twisting force that is produced by the engine at the crankshaft and which turns the wheels on the road. It has a particular influence on vehicle performance when moving off and when climbing hills. The torque output on light motor vehicles is relatively low but on heavy motor vehicles it is deliberately very high. The driver controls the torque output by using the transmission (gearbox) to compensate for vehicle and road conditions.

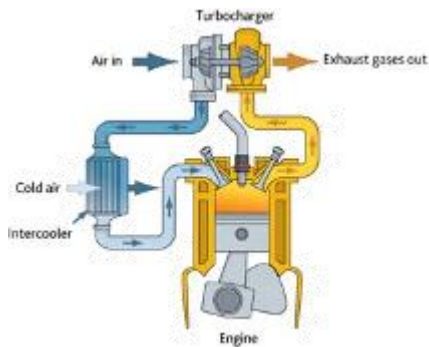

Attached to the engine are the fuel, electrical, cooling and exhaust systems, all of which influence engine performance. The addition of electronic fuel management systems, turbochargers and intercoolers, for example, will boost engine performance noticeably.

Common fuel options include petrol, diesel and LPG with electric and hybrid vehicles becoming much more common, especially in metropolitan areas. Most modern vehicles use fuel injection systems where the amount of fuel delivered to the engine and the timing of those deliveries, is controlled electronically and far more efficiently.

## The transmission (gearbox)

The purpose of the transmission is to:

- provide a range of gears to suit all road and load conditions
- provide a neutral gear position
- provide a means of reversing the vehicle
- allow the engine to operate at an efficient speed
- increase the torque delivered by the engine.

The majority of modern light vehicles use automatic transmissions which require less driver skill to operate, provide better control of power and acceleration and afford better observation responses from the driver as a result of less driver activity.

Manual transmissions, on the other hand, give the driver the ability to select and hold a required gear more effectively, provide better engine braking under deceleration, particularly on hills, and better power and torque management when towing.

With a manual transmission the gearbox uses constant mesh gears and a clutch assembly so that the driver can make gear changes. With an automatic transmission, a fluid coupling regulates the gear shifting although the driver can have some influence over this with the accelerator.

## The differential and traction control

Fitted to the car's driving axle, the purposes of the differential are to:

- allow the wheels to travel through different distances when cornering
- provide a further gear reduction (thus increasing torque)
- transmit the drive from the engine through 90 degrees to the axles.

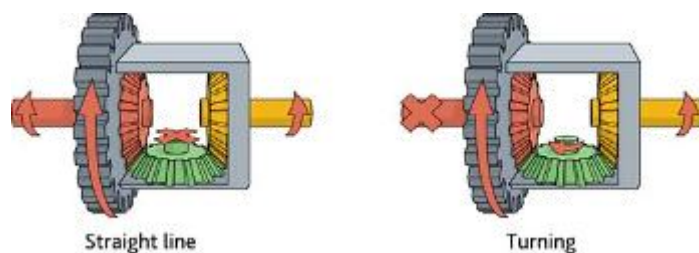

Traction control limits tyre slip on the drive wheels during acceleration on slippery surfaces. On most systems, the ABS sensors are used to measure the differences in wheel rotational speeds to determine whether any have lost traction. If the sensor detects one wheel turning faster than another it automatically 'pumps' the brake on that wheel to reduce its speed. This is usually enough to control the loss of traction. Some traction control systems also automatically reduce engine power so that the drive wheels resume turning at the same speed.

Traction control is necessary because power will always go to the point of least resistance which means that a wheel that has lost traction will receive all the engine power and the wheel that retains traction (the most resistance) will receive none. By eliminating wheel slip the power will continue to go to all drive wheels and traction and driver control is maintained.

Examples of when traction control might come into play include during loss of traction on a wet road, when climbing a hill, during loss of traction under harsh braking or acceleration (depending on drive wheel configuration), and during loss of traction on one side due to weight transfer or a change in road surface during cornering.

## Drive wheel configuration

While many large passenger cars and utility vehicles employ rear wheel drive, most small to mid-range vehicles are now front-wheel drive. An increasing number of light vehicles, particularly sport utility vehicles (SUVs) now use all-wheel drive which means all four wheels are driven by the engine and transmission system.

In relation to road handling each has its advantages and disadvantages.

### Front-wheel drive advantages

- Excellent directional stability.
- Safe handling due to under-steer characteristics that can be corrected simply by decelerating.
- Good traction on slippery roads due to engine weight over the drive wheels.
- Less likelihood of drive wheel lock-up due to weight transfer under braking.

### Front-wheel drive disadvantages

- Inferior towing performance due to weight reduction on drive wheels.
- Poor traction under acceleration due to weight transfer rearwards.
- Increased risk of rear wheel lock-up during harsh braking due to very light loads over rear wheels.
- Possible traction issues on slippery steep up-hill grades due to the weight transfer effect of gravity.

### Rear wheel drive advantages:

- Good balanced laden weight distribution provides very good general handling and directional stability.
- Good towing performance due to increased weight over the drive wheels.
- Good traction under acceleration due to weight transfer rearwards.
- Good traction climbing steep grades due to effect of gravity on weight distribution.

### Rear wheel drive disadvantages:

- Less unladen weight over drive wheels may cause traction issues in slippery conditions.
- Reduced weight over rear drive wheels under harsh braking may lead to drive wheel lock-up.
- Prone to over-steer which can be difficult to correct.

### All wheel drive advantages:

- Improved traction, particularly on slippery roads.
- Improved hill climbing with no noticeable adverse effects of gravity.
- Better adhesion through corners.
- Less weight transfer effects.
- Better towing performance.

### All wheel drive disadvantages:

- In the event of all-wheel loss of traction, correction is difficult.

Driving instructors need to have regard for the vehicle the trainee drives under instruction and the vehicle they will drive once training has been completed.

## The braking system and ABS

The purpose of the braking system is to:

- hold the vehicle in a stationary position
- allow the driver to slow the vehicle and bring it to a stop under control.

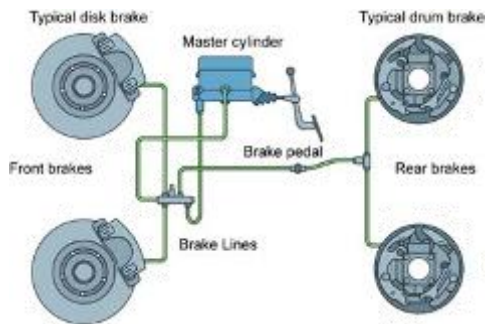

While drum brakes are still common on older vehicles, particularly on the back axle, most modern cars are fitted with disc brakes that offer improved performance with less heat retention, and more efficient braking, particularly in relation to stopping distances.

ABS is an electronic anti-lock braking system that uses sensors to monitor wheel speed. If a wheel reaches lock-up point, a control unit quickly, and continuously, releases and reapplies the brake until the wheel turns at the correct speed. The key advantages of ABS braking are that they:

- allow the driver to continue steering in emergency braking situations
- prevent wheel lock-up and consequent loss of directional control in an emergency.

ABS only operates if a wheel, or wheels, reaches lock up point. Having it fitted to a vehicle does not constitute a reason for increasing driving speeds or reducing following distances. In an emergency the driver simply stamps on the brake pedal and the electronic control unit takes over and controls the braking effort. The driver must, however, remember to continue to steer the vehicle to avoid the hazard.

## Electronic stability control

Stability control ensures the vehicle stays on its correct path on the road when the driver steers the vehicle in a new direction. It uses electronic sensors to detect changes in wheel speeds and, like traction control, uses the ABS system to apply the brakes on, or reduce power to, the inside wheels to allow the vehicle to continue along the driver's intended path. The system prevents the vehicle spinning out or skidding off the road or into another lane but does have limits in relation to vehicle speed.

Examples of when stability control might be initiated are when a vehicle under-steers or over-steers, during cornering as a result of excessive speed or when turning sharply on a slippery road surface.

## Power steering

Manual steering, usually found on older or some very small cars, requires the driver to provide all the steering effort to steer the car, assisted only by a steering gearbox to provide a degree of steering effort reduction. The steering wheel is of a size that maximises the 'law of the lever'.

Power steering, on the other hand, uses the same basic steering components but includes an engine driven pump to provide hydraulic pressure 'on demand' when the driver turns the steering wheel. This hydraulic pressure reduces driver effort to a minimum and eliminates the need for a large steering wheel.

The key advantages of a power steering system are that they:

- minimise driver fatigue and driver effort improving performance
- lessen kick-back from road shocks at the steering wheel
- better resist any sudden swerving as a result of rapid tyre deflation
- reduce the need for continuous minor steering corrections.

## Tyres

The purposes of a tyre are to:

- transmit the driving, braking, steering and cornering forces from the vehicle to the road
- support the weight of the vehicle
- provide cushioning to protect the vehicle and its occupants.

There are two different types of tyre construction. Cross ply tyres use a criss-cross arrangement of the cords that make up the plies. This provides both the cushioning and the directional strength of the tyre and is ideal for mainly metropolitan/city running.

Radial ply tyres use ply cords running at right angles to the circumference of the tyre. Cushioning is provided by very flexible side walls while directional strength is achieved through the inclusion of a stabilizer belt underneath the tread. While generally more expensive, these tyres offer the best performance in highway driving. They provide better road holding and better traction.

Mixing tyres of different sizes and construction can lead to serious vehicle handling and performance issues and the following points must be noted:

- Different tyre sizes on the same axle: Different tyre widths will affect traction during acceleration and braking and traction and slip angles during cornering. Different tyre profiles will affect steering and slip angles and adversely affect handling in corners.
- Mixed radial ply and cross ply tyres on the vehicle: This results in different slip angles during cornering that can lead to serious over-steering problems or unexpected handling characteristics in corners.
- Mixed multi-directional and directional tyres on the vehicle: Markedly different tread patterns produce different degrees of road handling performance. Once mounted on a wheel a directional tyre can only be fitted on one side of the vehicle. Placing on the wrong side will compromise tyre performance, the tyre's ability to clear water on wet roads and vehicle handling.

Low profile tyres are increasing in popularity, particularly with young drivers and do offer better performance at higher road speeds. They provide better traction due to a wide 'footprint', better cornering stability due to rigid sidewalls, less body roll, better steering responses and are able to withstand a greater braking effort. They are, however, more prone to rim damage, provide a much harsher ride at low road speeds and are much noisier from a driver/passenger perspective.

Tyres fitted to wide wheel rims offer improved traction during acceleration and braking and improved road holding during cornering but these attributes really have relevance only at highway speeds.

Tyre pressures have a direct influence on vehicle handling and should be checked on a regular basis. These checks should be conducted when tyres are cold and pressure adjusted to reflect the manufacturer's recommendations. Under-inflated tyres, besides increasing fuel usage and accelerating tyre wear, can have the following effects:

- Tyre failure and possible loss of control.
- Instability and excessive body roll during cornering.
- Over-steer in corners as a result of increased tyre slip angles.
- Reduced ground pressure in slippery conditions.

Over inflated tyres, on the other hand, can have the following effects:

- Loss of cushioning properties.
- Tyre failure due to impact damage with possible loss of control.
- Smaller footprint reducing traction during cornering and braking.

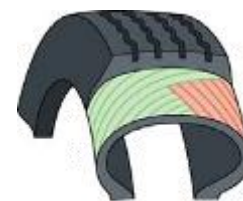

Cross-ply tyre

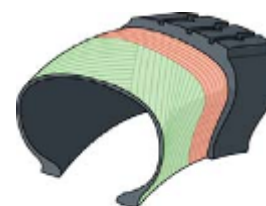

Radial-ply tyre

Warrant of fitness requirements demand that tyres have a tread pattern depth of at least 1.5mm (excluding any tie-bar or tread depth indicator strip) within all principal grooves that contain moulded tread depth indicators around the whole circumference of the tyre. Virtually all tyres will have moulded tread depth indicators but for the small number that don't (such as some retreaded or vintage tyres) the minimum tread depth requirement is 1.5mm tread across  $\frac{3}{4}$  of the width of the tyre and around the entire circumference.

Failure to ensure tyre treads meet this minimum standard can lead to a tyre being unable to pump water clear of the tread contact area on a wet road, particularly if there is standing water. This, in turn, can lead to aquaplaning and loss of driver control.

Tyres should also be checked for damage, particularly on the side walls where contact with the kerb or other sharp objects can occur. Any damage should be checked by a qualified tyre fitter and their recommendations followed.

## Wheel balancing and alignment

A wheel rotating at high speed is not naturally balanced. If it is not balanced, the force of rotation can cause it to lift off the ground, dragging it backwards and forwards with each revolution. Any small imbalance is exaggerated exponentially as speed increases. This affects steering, suspension and tyres and vehicle handling overall. Wheel balancing is an important part of the process when replacing tyres or at any time one wheel has been replaced with another.

Wheel alignment refers to the adjustment of the wheels on the steering axle. Improper alignment leads to excessive wear of both tyres and steering components.

Toe in and toe out: If we think of the front of the steering tyres as the 'toe' and the rear of the tyres as the 'heel', then 'toe in' means there is less distance between the 'toes' than the 'heel' and 'toe out' has the opposite meaning – the 'toes' are further apart than the 'heels'. A little 'toe in' is required to balance wheel camber but incorrect adjustment will lead to excessive wear around the edges of the tyres. Adjustment is made at the tie rod ends.

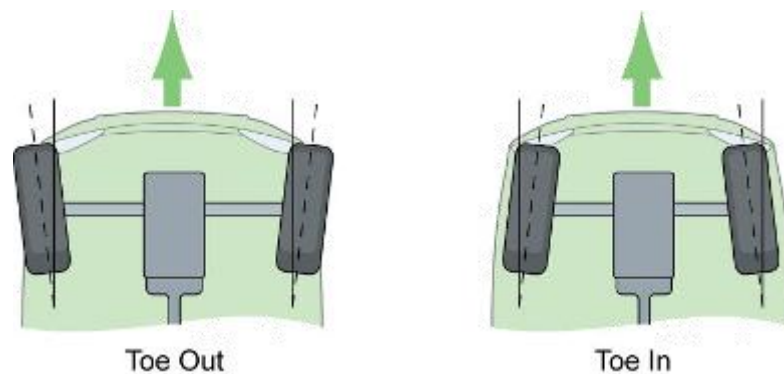

Camber: This is the position of the centre of the tyre. If the tyre is straight up and down it has zero camber. If the top of the tyre leans away from the vehicle it has 'positive' camber and if it leans towards the vehicle it has 'negative' camber. A little positive camber is applied to the front wheels so they will pull away from the vehicle at speed and assist with traction and this is balanced with a little 'toe in'. Incorrect camber can lead to road shocks, tyre wear and steering wander.

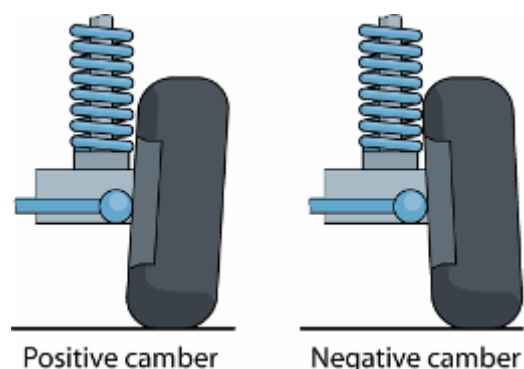

Caster: This is the position of the tyre in relation to the king pin. 'Positive' caster occurs when a line drawn through the king pin hits the ground in front of the tyre. 'Negative' caster has the line contacting the ground behind the tyre. Positive caster allows the steering wheel to return to a straight ahead position after negotiating a corner. It also makes the front wheels more stable. Incorrect caster can lead to low speed shimmy and wandering and high speed front end instability.

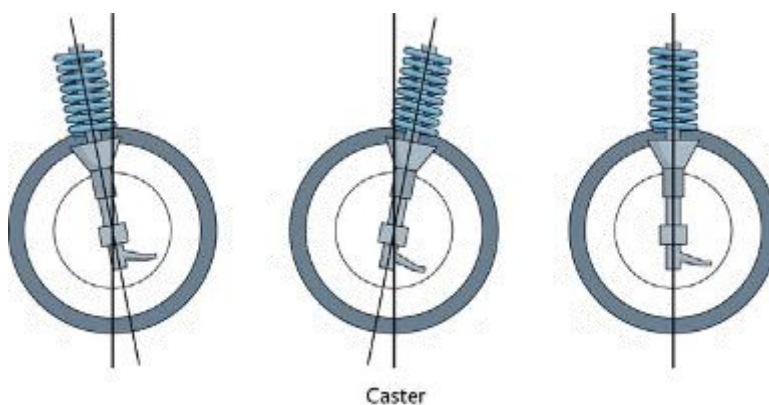

Caster

### Space saver wheels

In recent years, the spare wheel fitted to a large number of imported vehicles has been replaced with a 'space saver' wheel. These have a very narrow footprint, are often of a smaller diameter than the other wheels and are fitted with a tyre of a much lower construction standard than normal. These tyres are designed for relatively short distances at reduced speeds and are inflated to a much higher pressure. As a result, the wheels are not capable of sustaining the normal forces of driving at high speeds.

If you have a puncture and fit a space saver to replace the wheel remember that the vehicle speed must not exceed 80km/h (or any lesser speed displayed on the wheel).

The space saver is for emergency use only and should only be used to get the vehicle to a place of repair.

### Suspension system

The purposes of a vehicle suspension system are to:

- assist in maintaining tyre contact with the road
- support the weight of the vehicle
- isolate the vehicle for road shock.
- Provide a degree of roll stiffness to the vehicle.

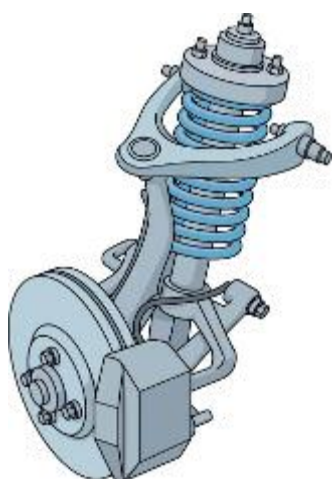

There are two general types of suspension. Independent suspension has each wheel on the vehicle independently suspended using combinations of linkages, torsion bars, coil springs and shock absorbers. It offers better road holding, more accurate steering, reduced steering feedback and less body roll.

Non-independent suspension uses a beam axle construction often mounted on leaf or coil spring assemblies. This type of suspension is now generally found only on some light four wheel drive vehicles where the suspension offers some advantages over very rough ground.

Active suspension is technology that controls the vertical movement of the wheels via an onboard computerised system rather than the movement being determined entirely by the surface on which the car is driving. The system therefore virtually eliminates body roll and pitching forwards and rearwards in many driving situations including cornering, accelerating and braking. This technology allows car manufacturers to achieve a higher degree of both ride quality and car handling by keeping the tyres perpendicular to the road in corners, allowing for much higher levels of grip and control. The onboard computer detects body movement from sensors located throughout the vehicle, and, using this data controls the action of the suspension.

Faulty suspension, usually due to worn suspension components, can lead to increased risk in high speed cornering and under hard braking. Stopping distances can actually increase as a result of faulty or worn components.

## Automobile dynamics

Laws of physics govern every aspect of our lives on earth and everything that moves, including us and the vehicles we drive, are affected by these same laws.

### Gravity and mass

Gravity is the force that attracts everything towards the centre of the earth. It is, quite simply, the reason we, and our cars, can stand on the surface of the planet. Any object that has mass (weight) is affected by gravity. (For our purposes the terms 'mass' and



'weight' have the same meaning.) In dynamic terms, the mass of an object is measured as 1gravity (1g). It doesn't matter if the object is a person, a car or a truck. While one may weigh 100kg, another 1200kg and the third 40,000kg, each, on the ground, is 1g.

Changes in direction and speed (velocity) can increase the effects of gravity on an object. The driver of a formula 1 racing car, for example, will regularly experience forces of 2–4g, and more, when cornering, accelerating and braking. What this means is that their body weight, to all intents and purposes, increases by 2–4 times. For the pilots of fighter aircraft this can increase to 7 or 8g as they turn and climb at extremely high speeds. For the rest of us, the same principles apply, but to a much lesser degree, when we go around a corner, accelerate or brake.

### Centre of gravity and weight transfer

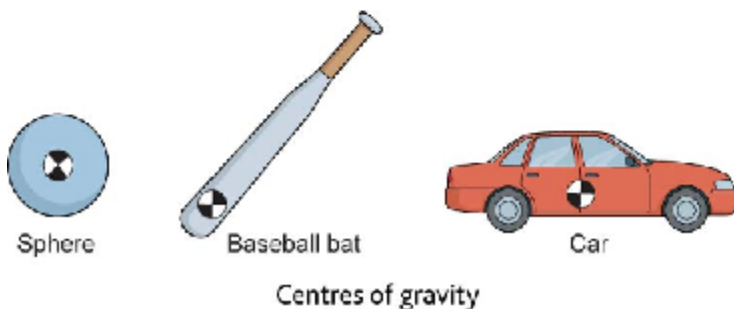

If we accept that gravity is the reason our cars have mass (or weight) then we also need to understand that, like every object that has mass, there is a theoretical point around which the vehicle is balanced in all directions. This is known as the 'centre of gravity'. For many objects, this centre of gravity is constant, it never alters. A solid cube or sphere will always have a centre of gravity that is in the exact centre. The

centre of gravity of a car, however, is not constant. The addition of any load will alter the centre of gravity. This can occur when we add passengers and freight, and even fuel, to our vehicles. We can also, as we shall see, move the centre of gravity by the way we drive.

Even with a correctly placed centre of gravity, weight transfer will occur during acceleration, braking and cornering or when towing a trailer and alter, even if only momentarily, the point of balance. The faster a vehicle is travelling, the more weight transfer there will be.

#### Under-braking

- Weight transfers forward.
- Loading increases on front axle.
- Loading decreases on the rear axle with the possibility of wheel lock-up and loss of directional control, particularly on low friction surfaces.



Under braking

### Under-acceleration

- Weight transfers rearwards.
- Loading increases on rear axle and wheel spin may occur due to over acceleration, particularly on low friction surfaces.
- Loading decreases on front axle and steering tyres.
- Snaking can occur which requires accurate steering corrections.



### During cornering

- Weight transfer will occur towards the outside of the corner (centrifugal force).
- The height of the vehicle centre of gravity will influence the vehicle stability.
- Loading increases on the outside wheels and decreases on the inside.
- If the slip angles are excessive the vehicle will over-steer or under-steer, depending on drive configuration, or slide out.
- High centre of gravity vehicles, such as four-wheel drive vehicles (4WDs), might roll over.

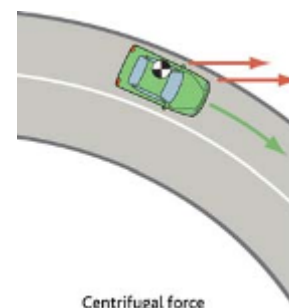

### When towing:

- An element of trailer weight transfers to the rear of the towing vehicle.
- This increases loading on the rear axle and can reduce loading on the front axle.
- Overloading of the rear axle can cause serious steering problems.
- Incorrect loading of the trailer, combined with speed, can lead to dynamic instability and loss of control.
- Excessive trailer weights will lead to poor vehicle performance and an inability to maintain efficient progress.
- Braking performance will also be compromised.



Effects of trailer on centre of gravity

### Friction

Friction occurs when two surfaces move in contact with each other. With a motor vehicle this can occur in the engine and transmission, because of all the moving parts, at the brakes and where the tyres contact the road. Friction in vehicle components is not desirable and is minimised by lubrication (oil). Friction at the brakes and at the tyres *is* desirable because friction produces heat. In braking, this can be extreme and reflects how much energy is contained in the vehicle when the driver brakes. Between the tyres and the road, the temperature influences the 'grip' the tyres have on the road.

Friction at the tyres is necessary for driving, steering, braking and cornering the vehicle. Low friction surfaces such as gravel or ice can result in loss of steering control, increased braking distances and loss of traction under acceleration or when cornering, particularly if speed is excessive.

There are a number of low friction surfaces where traction is reduced and precautions are required:

Ice or snow on the road: Friction and, therefore, traction may be almost completely lost in these conditions and stopping distances may be increased by five to ten times that of ideal driving conditions. On slippery surfaces, a quick turn of the steering wheel, hard braking, or rapid acceleration can result in the loss of wheel traction. Braking progressively and avoiding sharp changes in acceleration or direction will minimise the risks. Using tyre chains in extreme conditions will reduce the risks associated with loss of steering control or traction in snow. Make sure the chains are attached to the driving wheels, however!

If the car starts to over-steer, turn the front wheels in the direction of the skid and decelerate. Depressing the clutch might also help in regaining control. If the car under-steers, back off the accelerator and continue to steer in the desired direction. When starting on ice or snow, apply power gently; don't spin the drive wheels.

**Wet road:** Wet roads reduce friction. This is particularly true during the first 20 minutes of drizzle or rain because grease, rubber, oil and dirt on the road can make a very slippery emulsion until they are washed away. During wet weather, it may be unsafe to drive at posted speed limits. Drive to the conditions and increase following distances to make allowances for increased stopping distances.

When it rains, a film of water forms on the road and if a car is being driven too fast, or the tyres have insufficient tread to clear the water off the road, a wedge of water can form in front of, and under, the tyres. The car then slides on the water's surface. This is called aquaplaning and it will lead to loss of steering control.

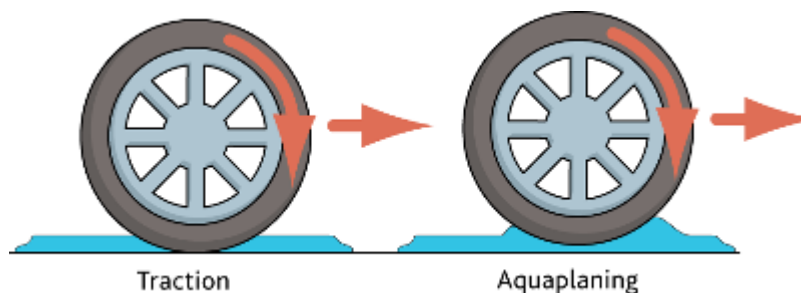

A tyre, in good condition, should remove up to nine litres of water per second. When water on the road is deeper than the tyre tread depth, however, a car might also aquaplane. If this occurs, the steering will feel extremely light and steering control will be lost. Slow down gently by decelerating until the steering feels normal again.

When a road is flooded it becomes extremely dangerous. If the water is less than 30cm (about 12 inches) deep and the road is in a good state of repair, a car should be able to get through without too many problems. One important point, however. If there is a flow of water across a road do not enter the flooded area.

Reduce speed and select low gear before entering any flooded area. Excessive speed will throw water up onto other vehicles and might very well drown the engine of your own car. If you can, keep to the centre of the road.

When passing through water, brake linings get wet. Drivers must test the brakes before continuing at normal road speeds. The linings can be dried by lightly applying the brakes while driving slowly or by pumping the brakes.

**Gravel roads:** Friction between the tyres and the road is greatly reduced on gravel roads. Small stones rolling under the tyres reduce the friction and, if the road is rough, the car can bounce, further reducing traction, steering, and braking control. Deep, loose gravel presents an additional hazard, as it may retard one wheel more than the other and cause the car to suddenly change direction. Reduce speed on gravel roads to allow for greater stopping distances and try and follow the wheel tracks of other vehicles in deep, loose gravel.

## Velocity and speed

The term 'velocity' relates to the rate of change in an object's position. It is a combination of speed and direction and is usually measured in metres per second in a specified direction, eg 27 metres per second north east. Velocity has a direct bearing on vehicle performance, particularly when it changes direction. The vehicle speed may remain constant but the change in direction produces other dynamic effects due to the change in velocity. For driver training purposes, however, the term 'speed' is more often used and readily understood by trainees. Speed can be expressed as either kilometres per hour (km/h) or metres per second (m/s) and is an expression of distance covered in a specified period or time. The greater the speed, however, the greater the effects will be of other dynamic forces working on the vehicle.

## Kinetic energy

Kinetic energy is the energy contained in a moving object. When one object hits another, the damage that is done is a result of the transfer of force from one object to the other. The greater the speed of an object, or the greater its mass, the more energy it contains and, potentially, the more damage it can do. A bullet, for example, has little mass but has extreme velocity. The damage it does to the target is a result of that energy passing from

the bullet into the target. A car, on the other hand, is quite slow by comparison but much heavier. It too can do a lot of damage because of its mass.

The effects of kinetic energy really come into play when braking, when cornering and in the consequences of a crash. The effects of it increase at the square of speed. This means that a car travelling at 60km/h will have four times as much kinetic energy as one travelling at 30km/h (twice the speed  $(2) \times 2 = 4$ ) and nine times as much as one travelling at 20km/h. (Three times the speed  $(3) \times 3 = 9$ ).

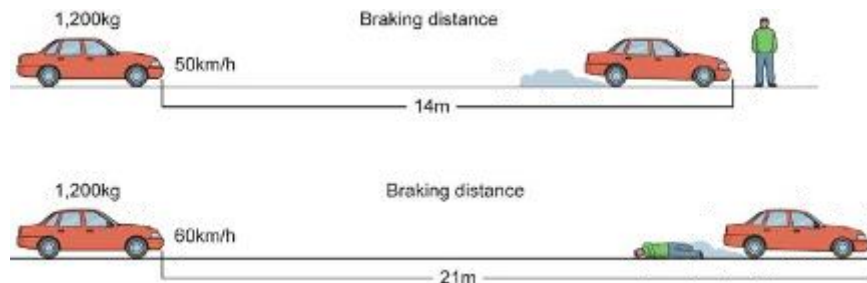

In a more realistic scenario, if a vehicle travelling at 60km/h passes another doing 50km/h, and both have to brake suddenly to avoid a situation ahead, the faster vehicle, because of the square of speed rule, will take about half as much distance again to stop

than the vehicle doing 50km/h. A key teaching point for trainee drivers.

The only way to stop a moving vehicle is to change this kinetic energy into another form of energy. The greater the speed, the more energy required to stop a car. By merely decelerating to a stop, the kinetic energy decreases very slowly as a result of friction occurring from air resistance and between the tyres and the road.

Because heat is another form of energy, the brakes offer the most efficient, and manageable, means of slowing and stopping a vehicle. The heat developed at the brakes rapidly converts the kinetic energy into heat energy and the vehicle loses its ability to do work.

## Centrifugal force

Centrifugal force is a term used to explain why an object's weight moves towards the outside of a turn if a change of direction occurs. If a ball is thrown it will continue in a straight line until another force, perhaps wind, acts upon it to make it change direction.

For a motor vehicle, the same effect occurs when the driver turns the steering wheel. The weight of the vehicle wants to keep travelling in a straight line but the change of direction prevents this. The friction between the tyres and the road holds the car on the road in the direction of the turn but an element of the vehicle's weight moves to the outside of the turn and this alters the position of the vehicle's centre of gravity. The faster the vehicle is travelling when this occurs, the greater the effects of centrifugal force. If it exceeds the resistance between the tyres and the road, the driver will lose control of the vehicle.



To manage the effects of centrifugal force during cornering, drivers must slow down if any of the following conditions exist:

1. Adverse weather conditions, eg rain, strong winds, ice.
2. If towing a trailer, caravan or boat.
3. If the vehicle is heavily loaded with passengers or freight.
4. If the vehicle is carrying any heavy items on the roof.
5. If the vehicle is a heavy motor vehicle.
6. If the road surface conditions are poor, eg gravel, potholes, ice.
7. If visibility restricts judgement of the severity of the curve.

## Under-steer and over-steer

Under-steer and over-steer: These are the possible consequences of tyre slip angles. Slip angles occur as a result of centrifugal force pushing the vehicle outwards on corners while the tyre adhesion tries to maintain a constant path. As the vehicle weight and the wheels move sideways, the tyre contact patches do not. As the wheels are no longer directly over the tyre treads, as a result of sidewall deformation, a difference exists between the direction of the tyre contact patches on the road and the direction in which the wheels are going. The angles formed by these differences are called 'slip angles'.

Modest slip angles are acceptable as tyres generate more grip with increasing slip angles but there is a limit, after which they become 'bad' and the tyres will lose their grip. If the slip angles for the front and rear tyres are the same (the tyres at the front and rear are generating similar levels of grip), the car will achieve neutral cornering. If, however, the rear slip angle is larger than the front one we have a condition known as over-steer while if the front slip angle is larger, the condition known as under-steer occurs.

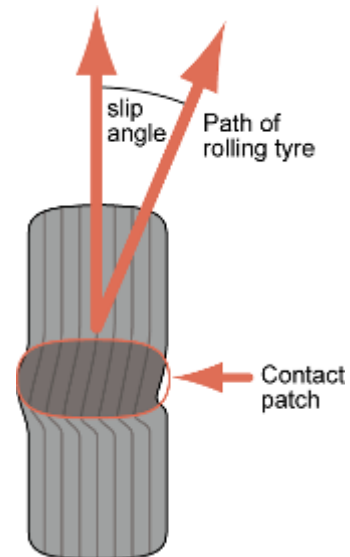

Slip angles result from a combination of tyre sidewall flex and tyre traction. If there is no traction (on ice, for example), then the slip angle will become zero. On the other hand, if a wheel travels in a direction other than the one into which its contact patch is pointing, then you have a slide angle rather than a slip angle.

Slide angles and slip angles are very different. Inertia determines the direction the car will travel if it slides. In other words, if you lose traction you will slide in the direction you were travelling at the time the slide started. So long as you have traction you will travel in the direction the contact patch points. Slide angle is the difference between the direction inertia sends you and the direction your tyres are pointing while slip angle is the difference between the direction your contact patch is pointed (the direction in which the tyre moves) and the direction the tyre is pointed. Reduced traction reduces slip angles and increases slide angles!

Under-steer can be identified by a vehicle's tendency to proceed straight ahead when cornering and is most common in front-wheel drive vehicles.

Over-steer can be identified by a tendency for the back of the vehicle to swing out when cornering and is more common in rear wheel drive vehicles.

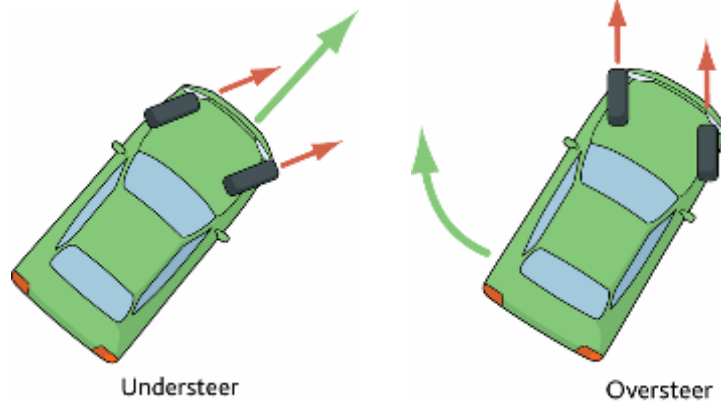

## Braking

When you brake, the vehicle and the load want to keep moving in the direction of travel. The centre of gravity shifts forward and places more load over the front axle. The effects of deceleration are also experienced by passengers and freight.

Under moderate braking, the effects of the dynamic forces are minimal. There is sufficient weight over all four wheels to provide effective braking and traction and vehicle control is not an issue. Passengers feel very little forward deceleration and unrestrained objects move forward but don't cause too many problems.

If you brake heavily, however, the centre of gravity of the vehicle transfers forward at a much greater rate of deceleration, forcing the front of the vehicle down even further on its front suspension. This weight transfer can be extreme enough to take almost all the weight off the rear axle causing the rear wheels to lose their grip on the road and lock up. Any unrestrained passengers and freight will continue forward at the original speed of the vehicle until something causes them to stop suddenly which, in turn, can lead to serious injuries, or death, for all vehicle occupants.

Drivers must understand the relationship between speed, weight and stopping distances. The faster and/or heavier the vehicle is the greater the distance required to bring it to a stop.

'Progressive' braking is usually the most effective way of braking quickly on tar seal surfaces (wet or dry). This type of braking requires the driver to progressively depress the brake pedal. The more the vehicle slows down the harder the brake can be depressed without locking up the wheels.

Another method of braking is known as 'cadence', or 'pulse', braking. This is very effective on low friction surfaces such as icy or gravel roads, when emergency braking is required and the vehicle is not fitted with ABS. Cadence braking mimics the action of an anti-lock braking system. The driver repeatedly, and quickly, stabs and releases the brake pedal. Because the most efficient braking occurs just before wheel lock up, this method maximises that efficiency without allowing the wheels to remain locked. Like ABS, it also allows the driver to maintain steering control.

## Acceleration

Acceleration has the opposite effect of braking. When you accelerate at a moderate rate, the centre of gravity of the vehicle transfers backwards slightly, but in this case the effect is usually offset by the weight of the engine and transmission at the front of the vehicle. This effect is also less noticeable with a front-wheel drive car.

When you use excessive acceleration, however, the transfer rearwards of the centre of gravity and the torsional effect of the transfer of power from the engine down the drive line to the wheels (in a rear wheel drive car) can significantly alter the axle loading at the front and rear of the vehicle. While weight increases over the drive wheels providing more traction, weight over the front wheels can be reduced to a point where steering control can be affected. With a front-wheel drive car, excessive acceleration can lead to wheel spin and loss of steering control.

On low friction surfaces such as gravel and wet or greasy roads, excessive acceleration quickly leads to wheel spin and possible loss of directional control.

## Cornering

When you drive through a corner or a turn, several factors affect the way your vehicle handles and performs and influence the effects on passengers and freight.

These factors are:

- vehicle speed
- severity of the curve or turn
- position of the vehicle's centre of gravity.

The faster your vehicle is travelling, the tighter the turn and the higher the centre of gravity, the greater the effects of centrifugal force will be.

### Cornering and speed

On New Zealand highways, road signs give drivers an indication of how severe a corner is and recommend a speed for negotiating the bend safely. This applies to any corner where a reduction in speed is seen as being necessary.

If training drivers of heavy motor vehicles make the point that they should negotiate any corner with an advisory speed sign at least 10km/h below the speed shown on the sign due to the size and weight of their vehicle.

When you take a corner at the recommended speed, the effects of centrifugal force are really minimal and neither the vehicle nor any passengers or freight, restrained or unrestrained, will experience any noticeable sideways movement. This is because the speed is such that the vehicle centre of gravity does not need to move sideways to any real extent and vehicle mass remains distributed evenly across all four wheels because



the suspension has experienced only a very minimal transfer of weight.

When you take a corner at high speed, weight transfer is much greater as the centre of gravity moves closer to the outside of the turn. The term 'high speed' is relative to the severity of the corner, however. A very tight bend will require a much lower car speed than a moderate corner. 50 km/h can be too fast for one corner while 100 km/h might be far too excessive for another. The consequences, however, can be the same. The severity of the consequences, on the other hand, will reflect the kinetic energy we touched on earlier.

The location of the vehicle's centre of gravity will also influence the likelihood of a loss of control situation. The higher the centre of gravity, the more likely the vehicle is to roll over. This is one reason why 4WDs can be quite dangerous in corners as owners load them up with baggage, roof racks included in many cases, and raise the centre of gravity.

Cornering at high speeds also leads to the uncontrollable movement of unrestrained passengers and freight to the outside of the turn which also accelerates the lateral movement of the centre of gravity and can lead to injuries.

Excessive speed pushes the vehicle sideways in a corner, can lead to over-steer, under-steer or loss of traction on all four wheels and increases the risk of a roll over for vehicles with a high centre of gravity.

### Cornering and braking

Braking in a corner is only required if the entry speed is excessive, something that can be avoided simply by observing the speed advisory signs. The majority of cornering crashes occur in the second part of the corner, usually as result of braking to reduce excessive speed. Because there is a weight transfer occurring during cornering, any reduction in speed in a forward direction, as a result of braking, leads to an accelerated sideways transfer of force. In other words, if the weight of the vehicle can't proceed in one direction it has the option of going in another, and does! This can lead to serious loss of directional control and 'run off the road' type crashes.

### Cornering and acceleration

Accelerating in corners is normally not an issue provided it is not excessive and road surface conditions are reasonable. Acceleration is actually part of the cornering technique. Excessive acceleration, however, particularly on a low friction surface like gravel or on a wet road, can lead to over-steer in rear wheel drive cars and under-steer in front-wheel drive cars, both of which can cause the vehicle to leave the road or cross the centre line into oncoming traffic.

### Cornering line and technique

There are three parts to a corner but no two corners are exactly the same:

- The entry to the corner is the point where you begin to turn the steering wheel.
- The apex of the corner is the point where the vehicle is closest to the inside of the turn and where the driver can see through to the exit.
- The exit from the corner is the point where the vehicle resumes a straight course.

### The cornering technique

To corner efficiently and safely, drivers need to apply a technique used by racing drivers who have an old adage that says 'Slow into a corner, fast out. Fast into a corner, you don't come out!' What is meant by this is that the speed for a corner must be set before you turn the steering wheel. Once the apex has been reached, the driver can accelerate out.

- Complete all deceleration, braking and downshifting before you enter the corner and steer into the corner at the desired speed.
- From the entry to the apex maintain your speed and correct road position.
- From the apex to the exit steering is complete and gentle acceleration begins through to, and out of, the exit.

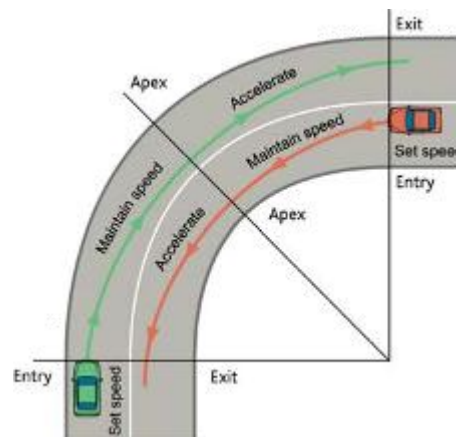

Obviously, the tighter the corner, the slower you should go. Think about the following points:

- As you enter a corner, you will notice a point ahead where the left and right sides of the road appear to meet.
- If this point does not move away from you as you negotiate the bend, it is a sign that the radius of the corner is quite sharp.

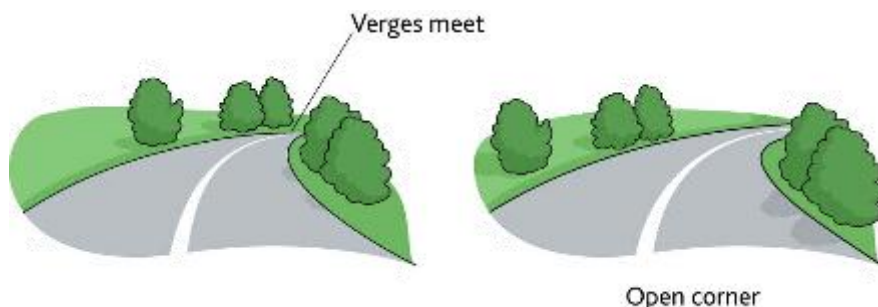

- If the point does move away, it means the curve will be less sharp.
- Once the two sides of the road separate, the exit is in view and you can start to accelerate.

### Cornering line

Another lesson taken from the motor racing fraternity is the cornering line that drivers should apply in conjunction with the technique described above. The correct cornering line will 'open' the corner up, giving the driver a better view into the curve and will reduce, at least to a small degree, the radius of the turn. This means the effects of centrifugal force are minimised and better use is made of available road space.

Cornering, in either direction, starts with the vehicle being placed on the outside of the turn, then travelling through to the apex and returning to the outside of the turn, in effect, straightening the corner out.

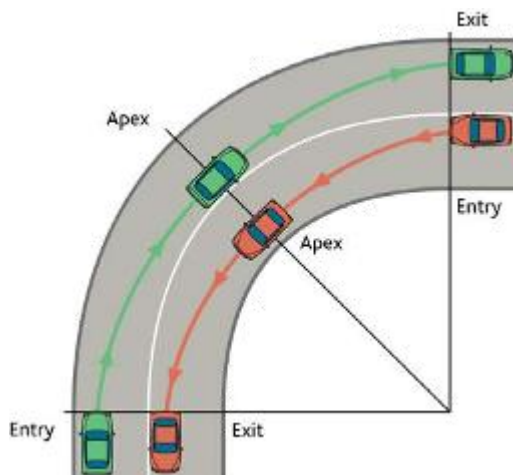

## Driving emergencies

Emergency situations are a potential threat for all road users.

While emergency driving situations shouldn't be everyday occurrences, drivers have to accept that the unexpected can occur with little or no warning. It generally isn't possible to practice responses to emergency situations, and good driver practices such as routine vehicle maintenance and effective observation skills will minimise the risks, but there are recommended responses that can 'save the day' provided drivers are aware of them and understand the reasoning behind them. The following scenarios are worthy of consideration:

**Brake failure:** A driver applies the brakes and the pedal goes straight to the floor. Immediately, pump the brake pedal. This will probably re-establish some brake pressure. If no pressure is recovered and the road ahead is clear, stay in gear and gently apply the parking brake. If possible, shift to a lower gear, using the engine compression to slow the vehicle.

If the brakes fail on a steep grade, or where the vehicle endangers other road users, immediately run the vehicle off the road into a roadside bush, a bank, a guardrail, even into parked cars. These are much better options than running out of control at extremely high speeds especially if there is oncoming traffic.

Use the horn and lights to warn other road users. Switching off the ignition can help but is extremely dangerous in vehicles with power steering. Be sure NOT to lock the steering.

The accelerator sticks: If the road ahead is clear, try to pull up the pedal with the toe of your shoe. If there isn't time, turn off the ignition and brake to a stop.

With power brakes and power steering, turning off the ignition disables both systems. Steering and braking will be difficult but will still work. Hold on to the steering wheel with a firm grip. Be sure not to lock the steering when you turn the key off.

If a quick stop is required, or the road ahead is not clear, leave the engine on and change into neutral or depress the clutch. Stop quickly and turn off the engine at once. A high revving engine without load will self destruct.

Under-steer and over-steer: Abrupt turns, sudden lane changes, sudden acceleration or hard braking can cause a car to skid, especially on wet or icy roads. If the rear end starts to slide out (over-steer), remove the foot from the accelerator at once and depress the clutch (if fitted). Turn the wheels in the same direction the rear of the car is skidding. When the car regains rolling traction, straighten the wheels and release the clutch. Never apply the brakes during a skid correction. If the vehicle has an automatic transmission, release the accelerator and steer as described.

For under-steer, where the front of the car is pushing to the outside of the turn, simply release the accelerator and continue to steer in the desired direction.

Tyre blowout: Firmly grip the steering wheel. Don't over correct. If a front tyre blows out, a strong pull toward the blowout side of the vehicle will occur. A rear blowout may cause the rear end to weave. DO NOT slam on the brakes. Decelerate and brake slowly and smoothly. Sudden braking may cause the vehicle to run off the road or into oncoming traffic. Get onto the shoulder of the road and drive slowly until a suitable place to change the tyre safely is found. Turn on hazard lights.

Headlight failure: If the headlights go out when driving at night, turn on the hazard lights, look for the road centre line and brake firmly. Ease the vehicle onto the shoulder of the road as soon as you can.

Fire: Most car fires are caused by faults in the electrical system or leaks in the fuel system. Stop as quickly and safely as possible. If the fire is in the engine compartment and you have a fire extinguisher, leave the engine running and fire the extinguisher through the grille. Be very careful about opening the bonnet as this will expose the fire to more air and possibly cause it to flare up.

If it is an electrical fire in the cabin of the vehicle, switch off the ignition, clear the vehicle of all passengers and open the bonnet. Endeavour to disconnect the battery cables even if this means ripping them out. Wires are much easier to replace than a burned-out vehicle. If you don't have a fire extinguisher, consider flagging down a truck. Many carry efficient fire extinguishers. Just remember to offer to replenish the extinguisher once you have used it!

If there is no fire extinguisher available, try to smother any burning wires with thick clothing or blankets. Don't grab burning wires with your bare hands. An electrical burn can be serious. If the fire is out of control, abandon the car before the fire reaches the fuel tank.

If the bonnet flies open: Brake smoothly. Look out the driver's side window or through the gap under the bonnet and use the road centre line of the left hand fog line as steering references. Move off the road as soon as you can.

Always check that the bonnet is securely latched after any servicing or after visiting a service station.

If forced to stop on a highway: On a motorway with paved shoulders, signal early and pull off at near traffic speed, then slow down.

Where the shoulder is unpaved, signal left and slow down to a safe speed before leaving the road. Use low-beam headlights at dawn or dusk, in darkness or in bad weather. Turn on interior lights and hazard lights.

If stopped on a curve, over the crest of a hill or any other potentially risky location, remove everyone from the car, moving well away from traffic. Don't obscure taillights at night by standing or working behind the vehicle.

If you have them, place a warning device about 5m behind the vehicle and another about 100 paces back. Raise the bonnet and use a cell phone if you think you need assistance.

Avoiding a head-on collision: Planning and concentration are needed to avoid a head-on collision – the most dangerous of all road crashes. In the event that an oncoming vehicle crosses onto your side of the road, sound the horn and flash the headlights and brake hard to reduce speed, steer to the left to avoid the collision and, if necessary, drive off the road. The chances of survival are much greater, even if you roll over, than they would be in a head-on collision.

Don't try to outguess an oncoming driver by swerving right. The other driver may recover at the last instant, instinctively veering left, hitting you head-on.

If the car plunges into water: Submersion is one of the most unpredictable motoring incidents, both in the way the car will perform once in the water and the way in which people will react. Water can cause understandable but unnecessary panic.

A car with windows and doors closed will float from three to 10 minutes. The best escape route is through a window.

It is difficult to open a door against water pressure so try not to panic. Windows can be wound down easily. Electric power windows may short out, so try to open them immediately.

Tempered glass in the side and rear windows can be broken but usually only with a heavy, hard object. Some windows, like the windscreen, will pop out if feet are pressed hard against them.

A front-engine car will sink nose first. As the car fills with water, some air is usually pushed to the rear near the roof. If the windows won't open, and the car is starting to sink, climb into the back seat to wait for pressure inside and outside the vehicle to equalise. It is then much easier to open a door.

If there are passengers, form a human chain, leaving the vehicle through an open window or door. Take control and try and avoid any panic. Remember that 3 to 10 minutes is a lot of time in an emergency.

How to change a wheel: Changing a wheel on the side of the road is potentially dangerous. This is the way to do it quickly and safely:

- When a tyre goes flat, grip the steering wheel firmly and guide the vehicle well off the road. Don't slam on the brakes.
- On a firm flat surface, apply the park brake. Place chocks, or large rocks, under the wheel diagonally opposite the flat. Get out the jack, wheel brace and spare tyre.
- Pry off the wheel trim, if fitted, with the chisel end of wheel brace or large screwdriver. Slightly loosen each wheel nut before jacking up the vehicle.
- Place the jack on firm ground, or on a board, making sure it is perfectly vertical. (See your owner's manual for directions on how to fit the jack supplied with your vehicle.) Set any jack control to the 'up' position, insert the handle and pump, or wind, the jack up until the wheel is clear of the ground. Remember you will need more room to fit an inflated spare tyre than you will to remove the deflated one.
- Remove the wheel nuts. Put them in the wheel trim, or your pocket for safekeeping.
- Lift the wheel off. Put the inflated spare on and screw the wheel nuts on, tightening the nuts until all are snug. When doing this, tighten diagonally opposite wheel nuts first.
- Lower the jack and let the car down. Tighten the wheel nuts properly with the wheel brace. Replace any wheel trim.

**WARNING:** A vehicle jack should only be used for tyre changing. Never crawl under a vehicle when it is on a jack.

Emergency equipment: The following list itemises equipment that a driver who does a good amount of driving might keep in the vehicle for possible on-the-road emergencies and that you should probably carry in any vehicle used for driver training:

1. Reflective triangles
2. First Aid Kit and manual
3. Portable electric light or lantern
4. Fire extinguisher – multi-purpose dry chemical is best
5. Jack and wheel brace
6. Tow rope
7. Jumper leads
8. Heavy screw driver
9. Spanners of various sizes
10. Pliers
11. Emergency windscreen
12. Emergency fan belt
13. Container of clean water.

## Section 2: How people learn

### The experiential learning process

People learn cognitive (practical) skills, like driving, by 'doing'. Learning is the product of action and a wide range of elements of learning by 'doing' are common in many fields including driver training. Hunters teach their children during a hunt, farmers teach their children on the farm and tradesmen train apprentices on-the-job. Learner drivers learn by driving cars. Globally, these learning experiences are referred to as 'experiential learning'.

Experiential learning is defined as 'learning which occurs while the learner is directly in touch with the everyday realities being studied'. Another description for experiential learning is 'learning by discovery'.

There are five sequential steps involved in the experiential learning process.

#### 1: Experiencing

The learner, in our case a trainee driver, becomes involved in the activity to be learned. The learner is observed initiating the learning experience in some way.

#### 2: Sharing

After initiating the learning experience, learners share their observations and reactions with others who have experienced the same activity.

#### 3: Integrating

The learner processes and integrates the information shared. Learners make the shared information part of their knowledge and skill bases by further exploration and discussion with others.

#### 4: Generalising

The trainee learns to extract principles or develop generalisations about the learning event. Verbalising these generalisations helps a learner to further define and clarify the integrated information.

#### 5: Applying

The learner applies the principles derived from the experience. The new learning must be used by the learner in a new situation, confirming the earlier experience, and initiating a new experience. Thus, the process returns again to step 1 experiencing, and the sequence is repeated.

A driving instructor can identify immediately the experiential learning process as the process which occurs when student drivers are learning to drive.

### Characteristics of adult learners

Whatever their natural abilities and aptitudes, the information and skills trainees learn must be achieved through attention and active involvement in the learning experience. Trainee motivation is vital to their ability to learn.

Experience has shown that the more adults learn on their own initiative, the more they permanently retain in long-term memory; much more than information learned by being 'taught'. Characteristics of adult learners which driving instructors will recognise while teaching learner drivers are:

- Natural ability varies from trainee to trainee.
- Some trainees are very nervous, others are overconfident.
- Trainee readiness to learn to drive differs due to other influences.

- Motivated trainees learn driving skills as rapidly as their abilities allow.
- Attitudes toward driving vary greatly.
- Motivated trainees behave differently toward learning driving tasks than timid trainees.
- Interests among trainees are diverse.
- Educational levels vary among trainees.
- Cultural differences must be recognised.
- Age, level of experience, and physical attributes and limitations differ.

Keep these characteristics of adult learners in mind. The more you know about each trainee, the more accurately you will be able to structure the training for that individual. You should get to know your trainees as quickly as possible, identifying interests, educational achievements, attitudes and motivation in order to relate to them personally and to formulate an appropriate training plan.

Adult learners, who want to change their behaviour or develop new skills, require five basic conditions for learning. These conditions are:

- They must want to improve.
- They must recognise their own strengths and weaknesses.
- They must work in a conducive environment.
- They must have assistance from someone who is interested and skilled.
- They must have an opportunity to try out new ideas.

You must encourage the first two learning conditions and provide the other three if effective knowledge and skills are to be developed.

## Characteristics of a good coach, mentor and facilitator

A coach trains individual trainees, provides guidance for learning tasks and primes trainees with information and skills.

A mentor is an experienced and trusted advisor to a trainee. A mentor encourages, leads by example and provides the personal support to trainees that often become necessary in what can be a very challenging and emotive learning experience.

A facilitator is a person who encourages trainee participation and acceptance of responsibility for their learning outcomes. They provide regular feedback and are capable of promoting the learning processes so that learners become increasingly more able to take charge of their own learning, maturing in the process.

At the beginning of a training cycle for a new trainee, driving instructors are coaches, imparting their knowledge regarding the psychomotor skills involved in manipulating the controls of an automobile. In the next phase of learning, driving instructors behave more like mentors, advising the trainees of the more subtle skills of driving, such as perception, observation skills and road craft. As trainees progress, you increasingly act as a facilitator of learning, not only coaching and mentoring trainees but also encouraging learners to take control of their own learning. To be an effective facilitator and to raise the self esteem of a trainee, you must have the following personal qualities:

- Congruency:** This means being yourself in the company of a trainee; not trying to be someone, or something, you are not; being compatible and complementary to the lesson.
- Empathy:** Accurately identifying and understanding how the trainee feels during the learning experiences.
- Unconditional positive regard:** Value and warmly accept the trainee for who they are.

If the learner perceives that you have these personal qualities, then they will tend to relax, concentrate more on the learning process and become more receptive to the learning process.

As a facilitator for adult trainees, who are learning by discovery and by the experiential process, and who are in the more advanced stages of driver training, you should:

- ask the learners for clarification of their perceptions relating to the driving environment
- ask the learners for their solutions to problems that arise
- seek to understand the learners' feelings, ideas, and motivations
- encourage and support the learners to use their own abilities as much as possible.

The facilitator's role is, therefore, that of a learner's helper.

Facilitating does not preclude you from imparting knowledge, facts, and solutions. You should, however, encourage trainees to ask for knowledge, facts and solutions. In this way, trainees take control of their learning by learning at their own pace, and internalise their learning according to their own abilities.

To be effective, driving instructors must debrief each trainee after each driving lesson. Debriefing includes an assessment by students of their own feelings and perceptions of the learning experience. This is part of trainee 'feedback' and where facilitators should be encouraging trainees to talk about each day's activities and experiences. This debriefing phase can be a stimulus to students' personal behaviour changes outside the learning situation. They take the knowledge and experience and begin to apply it into their driving away from the learning environment. An unsatisfactory debriefing can lead to aborted learning and the value of this aspect of training should not be under-estimated.

## Establishing a climate for learning

You must set a warm and positive climate for learning. This will engender feelings of mutual respect between the learner and yourself but it should be informal with both of you collaborating in the planning of instruction, establishing mutual objectives by participative decision-making. Part of this process is negotiating objectives for learning. Learning plans and activities are also accomplished by means of projects and independent study by the trainee between lessons. You and the learner should work as a team, evaluating learning progress after each lesson.

Many trainees enter into a new learning situation desiring a clear structural plan, ie an outline, timetable etc. Instructors must emphasise that both parties will work within any structure, but that the structure is a process of skill acquisition which does not suit a precise timetable. Trainees must be assured that you will make decisions about learning when they are unable to do so. They must feel comfortable that you know what you are doing but should also appreciate that they will be expected to take on more responsibility as their learning progresses. One role of an instructor is to help trainees assume that responsibility.

You must point out that when performance objectives are set, a clear explanation of what is expected of the trainee will be outlined. The learner will be evaluated against the agreed objectives, both at the end of each lesson, and at the end of any programme of lessons. Only if these evaluations occur can valid measurement of trainee progress be made.

## Learning concepts

A flowchart for one learning event is outlined below. A new learning event and existing knowledge are processed simultaneously by the brain. Based upon the trainee's attention, activity and involvement levels during the learning event, plus the sensory information processed by the brain, the learning event may be stored in memory as new information, knowledge, facts, or skills. Alternatively, the event might be discarded as irrelevant by the learner.

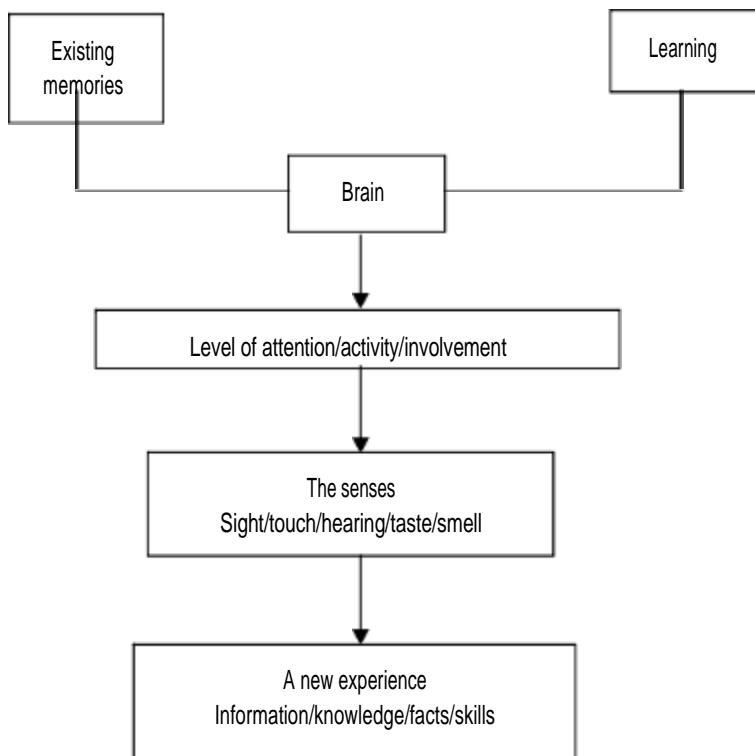

## The sensory system

The ability to learn is nature's way of enabling humans to adapt and survive in a changing and complicated environment. Learning is a continuous, but often inconsistent, process which instructors will endeavour to manage. Learning can be the result of a deliberate and directed effort but, on other occasions, can be the unintentional result of a chance experience. Examples of this in a driver training context might be the trainee's involvement in a vehicle crash and lessons accruing from that or, perhaps, the opportunity to travel with a very competent driver and observe the application of a high level of road craft.

The three principle senses that allow us to succeed in the learning process are sight, hearing and touch. 75% of new information reaches the brain through the eyes, making sight the most important sensory consideration for drivers. In a training environment, the visual (seeing), auditory (hearing) and kinaesthetic (hands on) sensory modes influence the trainee's ability to learn and each individual uses all three but will, in most cases, be dominant in one.

## Visual

Visual learners respond best to training methods which have a strong visual component such as pictures and graphs. About 30–40% of learners are said to be 'visual'.

Visual learners use phrases like: 'I see what you mean'.

Simply using data show slides with lots of words, for example, is not the solution for visual learners. Try drawing diagrams on a whiteboard, using lots of colour and use graphs or pictures to illustrate or provide a visual cue. Provide written instructions to support verbal instructions and colour code written material.

The 'demonstration' stage of teaching a practical skill, where the trainee can observe the task being carried out, is very important for visual learners.

## Auditory

Auditory learners respond best to training methods that focus on spoken words and sounds. This group includes about 20–30% of learners.

Auditory learners use phrases like: 'If I'm hearing you right...'

Give verbal examples to back up written or visual material. Auditory learners might also appreciate group discussions or working in pairs where they can discuss learning points. Include sessions where the learner has to verbally answer or repeat information.

The 'explanation' stage of teaching a practical skill, where the trainee can listen to explanations and discuss the finer points, is a key aspect of learning for auditory learners.

## Kinaesthetic

Kinaesthetic learners respond best to training methods that include hands on, physical activity. Learners who like to have something in their hands to play with are most likely to be this type of learner. Some 30–50% of learners prefer this method of training.

Kinaesthetic learners use phrases like: 'I don't have a handle on this yet'.

These learners tend to be the ones who struggle least with the manipulative skills required for driving because they prefer to learn and master the skill themselves through practice and self correction. A large percentage of occupational drivers, particularly in heavy vehicles, tend to fall into this group. They enjoy the hands on aspect of the job.

These three senses, plus smell and taste, provide humans with information about the environment in which they live. From these sensations, people learn. They are, however, personal to the individual and the sensory effects experienced by one may differ to other people perceiving the same experience.

The quantity and quality of learning depends, in part, upon how much attention the individual gives to the actual experience, and to the capacity of the learner to cope with the learning event.

## Perception

The process of interpreting and adding meaning to incoming sensations, called perception, is the next stage of learning. The information a student actually perceives during a learning event depends on the sensations, existing knowledge gained from previous experiences, and how the person has learned to view the world, e.g. with fear, with excitement, with anticipation.

Incoming sensations are compared instantly with existing knowledge from previous experiences. The nature of these memories either helps or hinders the learning of new information. If new information is compatible with existing knowledge, established memories are reinforced. If new information is incompatible with established knowledge, new information may be either partially or totally rejected.

Both perception and physical responses to incoming sensations seem to occur within the conscious decision-making part of the brain, directing the attention of the appropriate senses toward the chosen task. Attention is not always controlled consciously, however, and may be distracted or wander in an unrelated direction.

The brain's ability to establish these connections is considerable but establishing the memory connections takes time, repetition, and patience on your part.

## Memory

Humans have two types of memory: short-term and long-term. The ten billion cells in the brain can generate billions of memory inter-connections. The capacity of the brain is enormous but the input capacity is severely limited in comparison. The environment contains vast quantities of irrelevant information. The eyes alone, for example, can provide the brain with up to four million pieces of information per second. Besieged with this rate of new information, people need a biological method of controlling and selecting information that needs to be retained.

Environmental information is transmitted from the senses to short-term memory. There, it is analysed and processed prior to being stored in long-term memory. The brain selects and remembers information depending upon existing memories. When new information appears irrelevant or unrelated to, or disagrees with, existing knowledge, the data is easily forgotten. When new information is relevant or related to existing knowledge, it is either remembered or results in a permanent modification to existing knowledge.

## Remembering and forgetting

New, unused, information tends to be forgotten. Unreinforced existing memories can recede from consciousness. They are not completely lost, however. Research indicates that information relearned is more rapidly integrated than if no previous memory existed.

Although people have a great capacity for retaining information, recalling it to consciousness can prove frustrating. Recall requires a cue to bring back a string of associated knowledge. A string of events experienced together, or later modified, seems to be remembered in an interconnected pattern. A cue recalling any part of a memory may bring many associated memories back to consciousness. Many people use mnemonics, memory joggers, like 'ABC' for 'Always Be Careful' or 'IPDA' for 'Identify–Predict–Decide–Act' – to cue recall of information.

However, memory can also be deceptive. One cue may recall more than one string of information, leading to confusion. Also, information remembered may be quite different from events that actually occurred. Remembering events as they actually occurred often are restored only under clinical conditions.

Recall can either be facilitated or blocked by emotional factors associated with the memory. Highly emotional events produce vivid memories of an experience. Pleasure and satisfaction positively reinforce learning which helps these feelings to reoccur. Unpleasant emotions, like fear, negatively reinforce the retention of memories. Negative memories inhibit action causing unpleasant feelings while positive memories encourage actions which cause satisfactory feelings to be repeated.

## Summary of the learning process

- The sensory system perceives information.
- Sensory information is sent to short-term memory where it is processed before being sent to long-term memory.
- The brain decides if the information should be remembered based upon existing memories. If the information is relevant to existing memories, the memory is reinforced or modified.
- If the information is irrelevant to existing memories or cannot be related to existing knowledge, it is easily forgotten. Unused existing knowledge tends to recede from consciousness and be forgotten over time.
- Recall of a memory requires a cue to restore it to consciousness.

A number of points related to learning concepts impact on the job of driver training. For example:

- Sight is the most important sense for the driver. This means that a trainee driver learns most by seeing a picture, diagram, road layout, hazard, etc while listening to an explanation.
- Perceptions are personal to each individual. Until you understand how each learner perceives events in the environment, you cannot devise teaching strategies to help each learner reach each objective.
- You must reinforce training by asking students to 'over-learn' a skill until the skill becomes habitual. Unreinforced memories tend to be forgotten.
- New learning must build upon past knowledge, skills and experience in order for the learning to be relevant to and, therefore remembered by, each student. That is why you must mentor each student – finding out who they are and what they already know.
- Unused new information tends to be forgotten. So, if you want new information to stay with the learner, the information must be used by the learner.

- Find cues to alert students to possible situations in the traffic environment. What might follow a ball into the street – an animal or a child? What might be just over the crest of the next hill – a cyclist or a possible head-on collision?
- Positive memories reinforce positive actions and self esteem. Every objective met reinforces positive action. Every 'well done!' is positive reinforcement.

## The driver training learning process

The basic requirements for effective driver training are:

1. attention
2. involvement
3. activity in the task being learned.

Attention is not a completely conscious activity. Extended periods of undivided concentration can hinder learning if no break or change in the activity is provided.

When planning training, remember to distribute training lessons evenly over days and weeks rather than try and cram them in to shorter timeframes. For example, one hour of training a day is more effective than one hour of training twice a day or two hours training once a day.

Involvement in learning is the result of being mentally and physically involved in a learning event and is dependent, to a large degree, upon motivation.

Activity is not all physical. While learning to drive includes physical activity, mental involvement initiates the active physical responses. Physical activity alone is not sufficient when learning to drive. The more active and involved the student is in learning events, however, the more the student will remember.

An old proverb about learning states:

- What I hear – I forget.
- What I see – I remember.
- What I do – I know.

Two different, but key, approaches to learning are:

- Rote: The traditional approach to learning that consists of memorising lists, numbers, facts, and formulae and repetition which makes no demands upon understanding.
  - Gestalt: The progressive approach to learning based on understanding a whole concept or activity. It includes the ability to make connections and comparisons between new information and that which is already known.

## Rote learning

Most people have the ability to memorise information or complete actions without any real understanding of the process or knowledge of the subject. Information stored in this manner, in precise order, can normally only be recalled in the order it was learned, however. The alphabet and multiplication tables, traditionally, are learned by rote.

Rote learning, the lowest level of learning, is a foundation upon which more information can be added later to add more meaning. A soldier's ability to immediately rectify a problem with his rifle is best initiated through rote learning as it develops instinctive skills that will provide a degree of protection on the battlefield. Many driving control skills can, and are, also learned by rote so that they become instinctive and do not hinder the driver's observation and perceptual skills. Changing gear, using a signalling device and turning the steering wheel are examples of these.

## Gestalt learning

Gestalt learning is the ability of the learner to attach meaning to, and understand, new information, thereby learning more about the whole of a concept, which is more than just the sum of its parts. The soldier, for example, must understand the interconnection between his actions and those of his mates while manoeuvring on the battlefield and be able to adapt skills and knowledge to suit constantly changing conditions. For the trainee driver, exactly the same needs apply. Safely negotiating an intersection requires a lot more than just knowing the give way rule and driving generally requires the trainee to constantly adapt knowledge and skills to suit the driving conditions. Another way of describing gestalt learning is to label it 'holistic' learning. It is learning through recognising and/or making connections with previously established principles. This includes filling in gaps in existing knowledge and adding or attaching meaning to known information. Gestalt learning is important in any learning process and is a key factor in the development of road craft.

## The roles of rote and gestalt in driver training

Both rote and gestalt learning are important for retaining new information. You might teach basic driving skills in a rote manner to help the learner driver acquire the competence to move and control the car. In experiencing these, the learner extends that knowledge by analysing the information, and comparing and memorising the effects of it.

Information which began as a memorised list of actions takes on meaning. This initial meaning may not, however, imply an understanding of how to apply the information and/or skill in a new situation. Rote learning must be followed by a more meaningful approach to a task if the learner driver is to apply the new skill to other driving situations.

The difficulty experienced by driving instructors should not be whether to use rote or gestalt methods, but rather, in deciding upon the best mixture of the two. Poor teaching overemphasises rote learning, (do as I say) ignoring understanding (these are the reasons why). Equally, poor instructional technique can lead to progressive learning methods being applied before learners have a sound knowledge of basic rules and skills.

## Transfer of learning

Few people ask for driving lessons without bringing some basic knowledge and some required or acquired skills. You help trainees transfer those skills and knowledge to driving and experiential associations assist with this. A trainee who, for example as a pedestrian crossing a road, showed a degree of understanding relating to the judgement of speed, distance and timing, brings skills essential to driving. Experiential associations and the transfer of that learning make your job just that little bit easier.

### Interference with transfer

Previous learning, however, can also interfere with learning new skills and knowledge. A learner may, for example, have developed some sense of speed as a result of being a frequent passenger. If the trainee begins to drive at what he accepts as 'normal speed' before the basic manipulative skills are developed, the previous learning will severely interfere with the driver training process, perhaps dangerously so.

Interference of a different kind is apparent in the following examples. The interference arises from the widely held, but false, beliefs that a good driver always:

- changes down progressively through every gear when slowing down or stopping
- engages the park brake every time the car stops at an intersection.

This type of interference arises, most commonly, from dated driving skills passed down from one generation to another, normally within a family group. These, and other commonly held beliefs, may come into conflict with new information that you provide.

You must, therefore, acknowledge that trainees do not learn in a vacuum. They are subject to many conflicting views outside their brief learning experiences during driving lessons. When this type of interference occurs, you

must be tolerant of the trainee's problems through the period of 'unlearning'. This is where misconceptions and negative learning experiences are addressed.

## Types of learning performances

New instructors, erroneously, often decide which teaching techniques and resources to use based upon personal preferences. While this practice may be acceptable for the amateur driving coach, the professional driving instructor needs a more focused rationale for selecting instructional procedures that will result in effective instruction. Fortunately, an effective means for choosing instructional techniques exists, and this section discusses the first step in this procedure.

In the same way a tradesman selects a tool from a toolbox, by knowing what needs to be accomplished, you must choose an instructional technique by first identifying the kind of performance to be achieved. The basis for matching an instructional method with a performance standard is decided by identifying which kind of learning is involved in each performance objective.

To simplify the job of programme or lesson preparation, there are five types of learning performance:

- Discrimination.
- Problem definition and problem solving.
- Recall.
- Manipulation.
- Speech.

If you determine which of the five performance types is the one primarily associated with a task, the selection of course content, instructional technique and resources becomes much easier. Performance types are, however, often interrelated. For example, although the process of making a right turn involves manipulation, it also involves observation skills (discrimination) and hazard avoidance (problem solving). The important point is to identify the principal performance associated with each process or activity which then simplifies the selection of appropriate course content, resources and teaching method.

With the principal type of performance identified, content selection becomes a matter of answering the question, 'What are the enabling skills needed to perform this task?' If a task calls for moving through an intersection, what skills does the learner need? Knowledge? An ability to discriminate between traffic conditions? Manual skills? The answer identifies the instructional content associated with this step of the task. In the case of moving through an intersection, observation skills, not manipulative skills, are more important.

### Discrimination

Discrimination is the ability to tell the difference between two or more things. Being able to tell whether two driving hazards are alike, or different, is a form of discrimination.

How can a driver tell when they have a flat tyre? The driver discriminates a difference between the 'lumpy' driving being experienced and the mental image and memory of the smooth vehicle responses associated with inflated tyres. How do people know when a particular task needs to be done? They discriminate between the actual situation and their perception of what it should be. People tell the difference between a good and a bad job by comparing what has been done with their memory of what has been done previously.

Discrimination is called for wherever a task asks the student to:

- Distinguish one driving hazard from another.
- Decide when a manoeuvre has been done well.
- Determine when a task needs to be done.
- Recognise the difference between correct and incorrect procedure.

## Problem definition and problem solving

Once people discriminate (perceive) that a manoeuvre is necessary, that a job needs to be done, they normally proceed to do the task. Sometimes, however, they don't know what to do about it. The first step for the driving instructor is to define the problem. Find out what the cause of the problem is. Trainees can't fix something if they can't identify the problem in the first place. The process of defining the problem must involve the learner themselves so that they can locate the problem and, with the instructor, take the steps necessary to rectify that problem.

Whenever a task calls for students to figure out the best way of doing something or to decide what to do next, they are being asked to engage in problem definition and problem-solving. The process of problem-solving is addressed by you showing, or explaining to learners, cues or symptoms that should lead them to conclude that problem definition and problem-solving are necessary. Once these symptoms, and their possible causes, have been acknowledged you can then give the trainee sufficient instruction to solve the problem and sufficient practice to confirm consistency. Remember, problem-solving is achieved by highlighting the symptoms and then letting the trainee identify and then solve the problem.

Problem solving is not taught by showing trainees a problem and asking them to guess what symptoms would appear. Problem-solving relating to driving a car is best taught on the road, in a vehicle or by using photos or diagrams, not through the use of lectures. Trainees should be out solving problems, not talking or writing about them.

## Recall

When trainees are asked to carry out vehicle checks, you, as the instructor, are asking for a performance based on 'recall'. This is the information or actions that the trainee has learned previously, and which have been retained successfully in the brain's bank of knowledge.

A special type of recall is called 'sequencing', or 'chaining'. Sometimes a very precise sequence of steps needs to be followed to complete a task. Learning those steps, in the correct order, is an example of chaining. A defined sequence of steps must be followed when parallel parking or applying the system of vehicle control, for example. Learners must know which step follows which in these sequences. Although the process of 'recall' cannot be seen, it is still the key trainee performance associated with a visible activity. If students recite the names of all the in-car controls and instruments, the principal performance is 'recall', not speaking. Whenever the principal feature of a task requires the learner to know what to do, more than how to do it, the principal performance criteria is 'recall'.

If trainees are expected to demonstrate a specified performance whenever they see a certain traffic situation, then they must identify the cue and, using recall, apply the correct response. If the recall is related to explaining or demonstrating how something works, perhaps an engine or vehicle brakes, then a demonstration-lecture might be appropriate. It must, however, be followed by practice where the student is given the opportunity to describe the relationships between the component parts indicating how the components work.

The process of recalling is a mental performance and while it is possible to measure some performances with written tests or oral questions, in driver training recall is often linked to practical driving activities.

## Manipulation

Knowing what to do isn't always the same as knowing how to do it. If a trainee knows that the next step in a driving task is to change gear, for example, but they don't know how to do it, then the journey could be long and costly.

A mistake common to many new driving instructors is the belief that if trainees know what to do, they will also know how to do it. There is a vast difference between the learner who understands the theory of a task and the one who can competently apply that theory in practice. While it is very important to identify the manipulative skills performance of a trainee, if you list only these skills in task descriptions, then the lesson will fail. Either the task descriptions are inaccurate, or the decisions around which principal performance is assessed need review.

## Speech

For learner drivers, speech is merely a form of communicating information. For driving instructors, speech is an essential feature of providing direction and for imparting information and expectations of trainee performance. The way in which you speak will influence training success.

You should endeavour to ensure that pronunciation is correct, especially when communicating with people from different cultures. Terminology should be consistent and correct and the talking style should, at all times, be positive. Bad language must be avoided. Instructors will use verbal communication to:

- converse with learners
- ask questions
- respond to questions
- clarify
- reflect
- explain and describe
- provide feed-back
- counsel
- encourage
- mentor
- persuade
- empathise.

## Summary

- Select instructional procedures and resources based upon rational decision-making.
- Selection of instructional techniques is based upon defining the primary performance required to meet the instructional objectives.
- One type of discrimination requires the learner to tell the differences between driving hazards in different driving environments. A good teaching strategy to accomplish this type of discrimination is to have trainees compare pairs of photos or diagrams to identify these differences.
  - Another form of discrimination requires trainees to determine if a driving manoeuvre they have just completed is the same or different from their mental image of the 'perfectly completed' manoeuvre.
- A third form of discrimination requires the trainee to determine if a driving task should be carried out. The teaching strategy required is 'show and tell' in the car, or using diagrams, photos, slides, magnetic road layout or a road layout painted on a small board.
- Problem definition and problem solving is taught by cueing trainees with symptoms of problems and asking them to define the problem and state what action should be taken to solve the problem.
- Recall can be demonstrated by asking trainees to state orally, or in writing, their responses to a driving situation. The best situations to set up for students for this type of task are those which ordinarily should not be practiced on the streets, e.g. the bonnet flies up, the headlights go out, or the car plunges into water.
- Manipulative, skills are best demonstrated by students in cars. Don't forget the visual skills which must also be incorporated into driving manoeuvres.
- Speaking skills are included to remind instructors that speaking is a skill that they themselves have to master.

## Factors affecting learning

With all the best intentions and the application of all the best learning strategies, there are a variety of factors that will affect the ability of people to learn. Every trainee will arrive with 'baggage' of one sort or another that the driving instructor has to identify and manage. They include, but aren't limited to:

### Internal factors

Emotional states arising from issues outside the training environment, from the psychological make-up of the trainee or from the stress of the perceived challenges ahead. Trainees might be excessively nervous, sad, hyperactive, tearful or fearful.

Motivation might be positive or negative. This will be dependent upon the reason for attending the training. Trainees might lack motivation, they might have unrealistic expectations, they might be over-confident or they might be the ideal trainee or your worst nightmare!

Beliefs develop as a result of exposure to information or practices, sometimes good but often not. Trainees can arrive over-confident, with an unrealistic belief in their own ability, they might believe they have a 'right to drive' or they may have been positively or negatively influenced by family and friends.

Values relate to the importance the trainee places on personal responsibility and the rights of other people. Often this factor is linked to motivation and to attitude. Trainees might have low personal values or standards, they might totally disregard the rights of other road users and they might fail to apply basic safety measures like wearing seat belts.

Attitude is reflected in a person's behaviour. It reflects a person's feelings or emotions and is often indicative of previous experiences or the influences of others. Trainees might have negative or very positive attitudes, they might believe their rights take precedence over others, they might have a 'bullet proof' approach to driving, even in the very early stages, they may very well be heavily influenced by peers and have either a very professional or irresponsible approach to other road users.

Age in itself should not be an issue. Trainee drivers will be predominantly, but not solely, from the younger generation and continuing or remedial training will normally be with older, more experienced drivers. In the mature age group, training may result from doctor or testing officer referrals. Consider a lack of maturity, physical and mental reaction times, impaired vision or co-ordination. There may be dated skills or knowledge but a very positive rapport with you may occur and a range of very professional driving skills might also be apparent.

Prior learning is the bundle of knowledge the trainee arrives with. Trainees can be very well schooled by other family members or, conversely, very poorly informed. There can be misunderstandings or misinterpretation of traffic law and driving skills and the concepts of road safety can be flawed. Immigrants who receive driver training also have to re-learn previous knowledge to manage New Zealand conditions.

Cultural identity is becoming an important consideration for driving instructors. The large number of 'new' New Zealanders is creating opportunities for instructors but they must have regard for cultural sensitivities and seek advice, if in doubt, about how to approach a trainee or a trainee's sponsor. Consider specific cultural or ethnic issues, often gender related. There may be religious considerations, degrees of intolerance and, most importantly, language difficulties.

Life experiences often influence the demeanour of trainees and may be an issue you have to discuss with the trainee or sponsor. Consider previous exposure to car crashes, long periods of undetected excessive speeds, positive or negative experiences with family or friends and a lack of familiarity with vehicle types (manual transmissions, larger vehicles etc)

Physical state relates to physical abilities, or disabilities, and the effects of any outside influences. There may be physical handicaps, issues relating to size or stature, eyesight and hearing. Trainees must be monitored for any effects resulting from drunkenness or drug use, injuries or illness and fatigue.

Mental states may not be easily detected but look for obvious signs that the trainee is struggling with their emotions or have undergone a change in behaviour. These could occur from mental illness, stress, fatigue, drunkenness or drug use, or emotions such as anger or bewilderment that originate from outside sources.

## External factors

These factors are more applicable to class room environments, particularly with group training sessions, but elements of these should also be considered in relation to the in-car environment when conducting practical driver training.

Temperature and air circulation need to be controlled. If the venue is too hot, too cold, too drafty or too humid, it will lead to trainee discomfort and affect the learning process. If the building does not have air conditioning, open windows on warm days and have heating available during the winter. During practical driver training, consider the temperature inside the car and take steps to control this.

Lighting should be adjusted so that trainees do not have bright light shining in their eyes and they have sufficient light to carry out the work required.

Seating should be comfortable but not encourage trainees to fall asleep! The class-room layout should reflect the size of the room and of the group, the presentation media being used and the amount of interaction between the instructor and the trainees. Consider different seating layouts like hollow or open ended squares, herring bone, straight lines etc. When conducting practical training ensure the trainee's seat position is correct before commencing a lesson.

Noise that will distract trainees must be minimised. It might not be possible to eliminate it but control what you can control and pause if there is a loud external noise, like a train or aircraft.

Gender considerations must be applied at all times. This includes sexual orientations. Language must, at all times, be appropriate and gender or sexually biased comments and jokes prohibited and managed. Common courtesy must apply in all things and any biases, intentional or otherwise, discouraged. Any personal limitations must also be acknowledged.

Group size may influence the effectiveness of training but class-room sessions allow for the efficient use of instructors. An ideal ratio is four to six trainees per instructor if a group session involves practical activities but can be much larger in a general lecture situation.

Make sure each individual receives adequate attention and that you have sufficient space, with considerations to the other points raised here, for the activity.

The duration of instruction must be managed efficiently. Training sessions, in-classroom or in-vehicle, shouldn't exceed 45 minutes. Take a five minute break between lessons and make sure you allocate time in your programmes for morning and afternoon tea and lunch.

## Communication

The primary means of communicating with a trainee driver is verbal but human communication is fraught with potential problems and difficulties. How often do you hear people say 'that's not what I meant,' or 'you still don't see what I mean,' or 'you don't seem to understand my point'.

Whenever people communicate, there is always the risk of a misunderstanding occurring. Even when we are understood, we often fail to get others to think or behave in the way we want. Not a good result for a driving instructor!

### The objectives of communication

Whatever the reason for communicating, whether it's trying to persuade, inform, entertain, explain, convince or educate, people have four general objectives:

1. To be received (heard or read).
2. To be understood.

3. To be accepted.
4. To get action (including changing behaviour or attitude).

When people fail to achieve the first two of these four objectives, they, quite simply, fail to communicate. Whether the third and fourth objectives are achieved will be dependent on the communication! This can lead to frustrations expressed in phrases like, 'don't you understand plain English'? But language is, after all, only a code people use to express their thoughts and ideas. Remember, a code can only be understood if both parties attach the same meanings to the same symbols (words). Different meanings, especially in the English language, can be attached to many words. (About 70% of all English words have more than one meaning.) How a person interprets a spoken statement or written passage can be influenced by their education, their social environment, their personal beliefs and their relationship with the communicator. Often, it is a person's individuality that is the major barrier to communication.

## Non-verbal communication

We all use more than just words to communicate. Consciously or unconsciously, when people speak, and often, even when they don't speak, they communicate by other means.

Much has been written about 'body language' and instructors can reach a point where they start to become self-conscious about their own little quirks or they spend a lot of time trying to read their trainees' body language to measure how well things are going. While this shouldn't become a focus, you should be sensitive to the non-verbal messages that are presented by trainees. More importantly, you must learn to manage your own body language so that trainees do not receive the wrong messages.

- Facial expression: A genuine smile is a cue for conveying warmth, agreement and enthusiasm. It can reduce a learner's anxiety or provide positive reinforcement much more quickly than a whole lot of words.
- Gestures: Using gestures can liven up a presentation, show agreement of positive reinforcement (eg, nodding your head in agreement to a comment). Gestures can also be used to control a room or indicate directions in a motor vehicle. Movement of the hands and body can help explain or emphasise a point or emotion.
- Posture: How a person stands or sits can reflect attitude or interest. Slouching should be avoided. Your posture should reflect a professional approach to the job, a genuine interest in the trainees and a desire to impart information. Stand tall and sit up straight.
- Orientation: When talking to another person, always face them. Talking to trainees in a classroom, while facing a whiteboard, is a common error made by instructors and teachers. It is discourteous and, if excessive, is not conducive to effective learning. Talking to an individual while turned away from them, can make the person feel inferior and will discourage them from further conversations. In practical driver training where orientation is dictated by the seated positions of the instructor and trainee, take any opportunity to discuss the finer points of driving where face-to-face communication can be employed, perhaps on the side of the road.
- Eye contact: As a general rule, someone who doesn't maintain eye contact during a conversation is seen as being dishonest or untrustworthy. There are cultures, however, where eye contact, to a large extent, is avoided and instructors must be aware of this. Appropriate eye contact connects instructors with each of their trainees, can increase perceptions of their credibility and confidence as a trainer and conveys interest, respect and concern. It also encourages learners to pay attention.
- Body contact: For driving instructors, this aspect of non-verbal communication is a potential minefield. Other than for exchanging greetings, or taking control of a vehicle in an emergency, physical contact of any type must be avoided. You must not touch any part of a trainee, even if this might appear to be solicited.
- Proximity: The distance a person stands or sits from another person or group of people can have a direct bearing on personal comfort levels. Personal space is something most people value and when this space is impinged upon by someone else, they feel threatened and can become very defensive. As a general rule, personal space is about one metre or, in a slightly different context, handshaking distance.

- Nods of the head: These indicate agreement or disagreement and can encourage another person to speak, or continue speaking or behaving in a certain way. When listening to a trainee, it shows that you are listening and taking an interest in what is being said. It is an integral part of verbal communication.
- Appearance: Physical grooming and the choice of clothing are important for instructors. While jacket and tie are probably not seen as the norm today, there is an expectation that you will dress in a manner that reflects a professional approach to the job. Personal hygiene must also be of a high standard.
- Non-verbal aspects of speaking: The human voice is an instrument, and like any instrument it has pitch, rhythm, tone and timbre (character), volume and inflection (monotone or variation). When teaching, you should speak a little more slowly than you might in a normal conversation and use more pauses. This will give the trainees more time to follow what is being said and give you more time for thinking as well. A quick speaking voice tends to lack authority and makes it harder for someone to pose a question. Pausing also adds authority.
- Writing: While writing may not appear to be a very important aspect of non-verbal communication for driving instructors, there are considerations in relation to the layout, organisation, neatness, and general visual appearance of any training aids or visual presentations that are used in training. These must be of a professional standard, easily understood and capable of maintaining the trainees' interest.
- Vehicle communication: This aspect of non-verbal communication relates to the messages that are sent and received by drivers in everyday traffic scenes. They include signalling, establishing eye contact, hand signals or acknowledgements, the use of the horn or hazard lights, the position of the vehicle in the lane or road and the application of vehicle speed in a specific situation.

The non-verbal communication accompanying a message can be very powerful. The receiver uses these clues to help interpret what a sender means, especially if the words contradict the non-verbal messages they are sending. If, for example, the speaker is angry but trying to hide it, the body posture, eyes, gestures and facial expression may very well give the game away.

## Barriers to communication

Driving instructors have to acknowledge that there are barriers that can cause communication problems. To overcome these, or at least minimise the effects, you have to apply skills that will ensure that instruction is not hindered or the student disadvantaged as a result of misunderstandings. Consider the influence of the following on communication:

**Differences in perception:** The way people view the world is largely determined by past experiences and these can be influenced by nationality, culture, education, occupation, gender, age, and personality. All play a part in the development of an individual's perception of how things should be and can, and often do, influence responses to suggestions or ideas that are communicated in a learning environment. Understand that people view the world based on past experiences.

**Jumping to conclusions:** People often see only what they expect to see, or hear only what they expect, or want to hear, rather than experience the transmission of new thoughts or ideas. Always wait and listen and identify training ability before making a comment

**Stereotyping:** Because people learn from previous experiences, they often treat different people in occupations or endeavours as if they were all the same, For example, 'If you've met one, copper/student/foreman/car salesman/real estate agent, you've met them all!' Stereotyping is a perfect example of the 'self-fulfilling prophecy' that says someone is what they are because another person says so. Treat every trainee as an individual with personal strengths and weaknesses.

**Lack of knowledge:** To communicate effectively with a person whose knowledge of a particular subject is considerably less than that of the communicator, can be difficult. This is, however, exactly what the role of a driving instructor is. You (the communicator) must identify the discrepancies in the levels of knowledge or competency, and communicate in a manner that creates the desire to modify, or improve, existing knowledge or skills.

**Lack of interest:** A big communication barrier can be the receiver's lack of interest in the message being conveyed. While it is generally not a major issue in the driver training industry, it is possible, and can severely affect the assimilation of information by the trainee. It is very easy to assume that everyone wants to learn to drive but there are situations, perhaps with trainees who are sponsored by companies or those referred by the courts or parents, where a lack of interest is only too obvious. Appeal to the interests and needs of the trainee.

**Difficulties with self-expression:** If, as a communicator, you have difficulty finding the words to convey ideas, you will have to make an effort to improve your own vocabulary. Lack of confidence can also cause difficulties in communicating knowledge and skills but careful preparation and lesson planning will help overcome the problem as will, obviously, experience. Avoiding big words and using familiar ones, goes a long way in improving issues of self-expression.

**Emotions:** Emotional issues affecting either the trainee or the instructor can be a major barrier to communication. In extreme situations, it may prevent anything but the emotion being communicated. Avoid instruction if strong emotions on either side might cause incoherence or distort meaning, until the contributing issues have been addressed.

**Personality:** Personality clashes are a common cause of communication failure. You will have little, if any, influence over a trainee's personality but a change in your behaviour and approach, can result in a more satisfactory relationship with the trainee and produce worthwhile outcomes. It is your responsibility to modify behaviour, not the trainee's.

These, and other factors can cause communication to be ineffective or to fail completely during driver training. You must recognise that, as both a communicator and a receiver, you must make the learning climate as conducive to learning as possible so that all communication between yourself and your trainees remains effective.

## Overcoming barriers to interpersonal communication

Overcoming communication barriers is linked to the behaviour or attitudes that people exhibit. These often cause people to react defensively, inhibiting communication. Many behaviours, on the other hand, are positive and cause people to feel supported, facilitating effective communication. To minimise communication difficulties, consider the following:

**Equality:** Instructors who behave in a superior manner, by admonishing or lecturing the trainees, will not receive cooperative, friendly responses. Instructors who treat trainees as equals, who engender trust and respect, usually receive open and honest trainee responses. When attempting to develop a rapport with your trainees, you must not allow the trainer/trainee relationship to interfere with two-way communication.

**Spontaneity:** If trainees suspect you are playing games with them rather than behaving spontaneously, the usual reaction is resistance. They will easily sense insincerity and can become suspicious of your true intent. Honest, natural communication, however, usually ensures a similar response from trainees.

**Feedback:** Two-way, rather than one-way, communication allows both the instructor and trainee to develop a rapport and engenders a relaxed, trusting learning environment. The more complex the information being communicated, the more important it is that trainees are encouraged to question and discuss points of potential confusion. This can also allow you to modify the method of communication, clarifying the message to fit the trainee's level of understanding.

As receivers, instructors improve communication by providing feedback, by acknowledging performance, questioning and clarifying.

**Objectivity:** If a trainee suspects that an instructor's manner, facial expression, tone of voice, or choice of words reflects a judgement on performance, then the trainee may very well behave defensively or lose confidence. You will sometimes find it difficult to hide non-verbal responses to trainee performance, but hide them you must. You should be completely objective when communicating with trainees, not judgemental.

**Listening:** Instructors must listen to what their trainees say. Avoid the tendency to plan a reply while the student is still speaking. This could lead you to jump to conclusions. Concentrate on listening to what the trainee is

saying. If they believe that you understood what was said, then the trainee will continue to communicate with confidence.

**Problem solving:** Attempts to control another person verbally, or otherwise, imply that the speaker has better judgement and that the listener is inferior. Attempts at control could range from a threat to a disapproving frown. Such behaviour causes a defensive response, even if the better judgement is accepted by the trainee, and the ability to work together to solve problems diminishes. When you make it clear that you are trying to work with, and not above, the trainee, a supportive learning climate and improved communication follow.

**Face-to-face communication:** Accurate feedback and effective personal interaction is achieved most efficiently through face-to-face communication. People often, but not always, express themselves more fully, and with fewer reservations, when talking one-on-one. Some trainees, however, might communicate better in writing, or with access to written notes, than face-to-face. If you have a trainee who says little and poses few questions, you should ask the student if they want to make notes between lessons and, perhaps, bring them back for discussion.

**Empathy and sensitivity:** Driving instructors have to be sensitive to the trainee's world. Everyone is different in terms of values, needs, attitudes and expectations. Appreciating and being sensitive to those differences improves understanding of others and makes it easier to communicate with them. Communication that demonstrates empathy for the student's learning experiences will produce favourable responses. An aloof, clinical attitude, on the other hand, leads to indifference which, in turn, can lead to a breakdown in effective communication.

**Flexibility:** When instructors communicate, by manner and actions, that they will consider other perspectives and entertain new ideas, a cooperative learning climate is engendered and open communication encouraged. Most people are willing to be flexible and this is certainly a pre-requisite for you as a professional driving instructor.

**Language:** Use simple, direct language. Select words and phrases based on the level of understanding of the learner. Accurate choice of words and phrases means more effective communication with trainees especially once practical driver training commences.

**Redundancy:** If a message is unavoidably complex or very important, perhaps for safety reasons, repeat it several times in different ways if necessary, to ensure the trainee understands. Unnecessary repetition, however, can lose a trainee's interest and attention. Redundancy is required less in written and more in oral communications.

Overcoming communication barriers draws on all the interpersonal skills you have to be successful in the business. There will always be a few trainees with whom a rapport can be very difficult to establish. There will probably be clear reasons why this is the case and dealing with these should become your focus. Accept each trainee for who they are and treat them as individuals and equals. The potentially difficult trainees will often respond to positive and professional instructor standards, role modelling and mentoring.

## The context or situation

Just as a verbal message and any accompanying non-verbal messages may be interpreted differently by different people, different meanings can be attributed to a communication at different times and in different situations. People don't communicate in a vacuum and communication always takes place within a specific situation or context.

With driving instructors, the *situation* is a learning environment and the *context* is driver training. Learning environments have particular characteristics which make them different from other situations. These include the need for control, the development of effective communications and the management of the learning process. In order to communicate at all, people learn to recognise similarities in different situations and learn from past experiences. This is essential or communication would stumble at the first hurdle.

Looking for similarities in situations can be helpful, or it can hinder communication. The danger is that people will assume a situation is familiar and therefore assume they know what to say and do, and how to behave. For example, if a trainee expects the driver training environment to reflect their experiences at school, they will have some pre-conceived, but probably erroneous, expectations that can work in your favour.

You should recognise that trainees' attitudes to learning situations are established long before they are old enough to drive. Barriers to both learning and to one-on-one exposure to an instructor in a confined space (in a car) may be well entrenched but dealing with these issues should be fairly straight forward if you display and employ the attributes of a professional instructor.

## Effective communication

Having examined some of the barriers to communication, and identified strategies to help overcome these, we need to consider key points for communicating as effectively as possible. If you try to predict likely problems you can take steps to avoid them. Here is a list of questions to consider:

*First rule: Think ahead!*

Why is the communication necessary?

- What information must be communicated?
- What is the reason for speaking or writing?
- What must be achieved? Is it an action, a change of attitude, a change of opinion?
- What is the purpose? Is it to inform, to persuade, to influence, to educate, to entertain?

Who is the receiver?

- Who exactly is the audience?
- What sort of person is the trainee? What are their personality traits? What about their education, age, gender and status?
- How will the trainee react to the content of the communication?
- What does the trainee already know about the subject of the communication? Do they understand nothing, somewhat less or more than I do?

Where and when is the communication required?

- Where will the student be when receiving the information? Will they be in a classroom with other learner drivers or alone with me? Are they returning after several weeks of absence so that they must be reminded of earlier messages?
- At what point in the lesson does the information come? Am I replying to a question the trainee has raised or will the message represent the first the trainee has heard about this topic/problem/issue?
- What is the relationship between me and the trainee? Is the subject of the message the cause of any controversy or disagreement? Is the atmosphere strained or cordial?

The answers to these questions will help you with the next set of questions.

What is the subject of the communication?

- What exactly do I want to say?
- What needs to be said?
- What does the student need to know?
- What information can and can't be omitted?
- What information must be included in order to be:
  - clear
  - concise
  - courteous
  - constructive

- correct
- complete.

These are the 'six Cs' of effective communication.

How should the communication be presented?

- How should I communicate the information? Should it be with words, pictures or both? Which words? Which pictures?
- Which medium of communication is more appropriate? Written or spoken? A letter or a personal chat? A report or an oral presentation? A telephone call?
- How will the points be organised and presented?
  - Should a 'deductive' sequence be used, starting with the main point and then going on to the explanations/examples/illustrations?
  - Should an 'inductive' sequence be used, starting with explanations/examples/ illustrations and building up to the main point at the end?
- How will the desired effect be achieved? What tone must be used to achieve the objective? Which words must be used/avoided to create the right tone?

In many cases the answers to these questions will be readily apparent but remember that a trainee might perceive things rather differently than you. Consider these questions before dealing with information that might easily be misconstrued or learners that might struggle with assimilation. Having regard for these questions helps develop the verbalisation and questioning techniques that you need to achieve the right outcomes.

## Communication and the learner's needs

Successful instructors care for their trainees and are sensitive to their learning needs. These needs are as varied and complex as the differences in trainee personalities.

An early priority is to create a good working relationship between you and the trainee, in other words developing a positive climate for learning. The rapport that exists between you will influence the success of all communication during training and the ability of the trainee to admit mistakes and talk about fears and anxieties. The ability to laugh together and share experiences further cements that personal interaction.

Learning is founded upon mutual co-operation to develop the learner's abilities and confidence. You can achieve this by structuring the learning so that the trainee is exposed to increasingly complex tasks supported with appropriate, professional instructor communication skills.

## Presenting learning events

Driving instructors must have more than just a comprehensive knowledge of driving. You also require the imagination to transmit knowledge clearly, in a manner understood by the learner so that the trainee is involved in the learning process.

The selection of appropriate teaching methods is largely dependent upon the type of learning required of the trainee. Although driving is considered a practical skill, it involves three separate kinds of learning. These are:

### Knowledge

Good driving involves knowledge of the road rules, road craft, vehicle familiarisation and road safety procedures. Some aspects are learned more effectively in a group situation or as home-work while other teaching must take place on the road.

Remember, knowledge influences attitude.

## Attitude

Attitudes are formed over a lifetime of experience and exposure to the opinions and knowledge of others. Negative attitudes towards others on the road, and towards road safety generally, contribute to many road crashes. You must use gentle but persistent persuasion and set professional examples to convince trainees, where necessary, to make attitudinal changes. Group learning can be an effective tool in achieving this.

## Skill

While the basic concepts of skills can be addressed in a classroom, they are only developed when the trainee drives a car. Two sorts of skills that the driver must develop are:

### Perceptual

Perceptual skills are visual skills involving the judgment of speeds, distances and space, and include search and scan techniques and the identification of hazards. They work hand in hand with the manual, or manipulative, skills required to operate the car safely and accurately along a road.

### Manipulative

Manipulative skills relate to the physical responses to information gathered perceptually. They consist of all the actions the driver takes to actually drive the car. Steering, operating the clutch and gear shift lever, the accelerator and the brake pedal are all manipulative skills. Those required to drive a car with an automatic transmission, for example, are far less complex than those required to operate a car fitted with a manual transmission.

## Group learning

Generally, driving instruction is a practical activity best addressed, as already stated, on the road, in a car. Some aspects of tuition are, however, more effectively learned in a group environment. Not only can this lower costs for trainees but the benefits of positive peer pressure and learner interaction may cause some individuals to conform or modify their attitudes towards certain aspects of their driving.

Group learning does have limitations however. It should never be used in situations where one-on-one tuition is required and, obviously, it also requires a number of trainees needing the same instruction. Class numbers might be as low as two or three or as high as ten or twelve. The group learning experience ought to be integrated into practical tuition and be complementary to it. It must not replace it.

One advantage of classroom tuition is the ability to cover many important aspects of driving, road craft and safety that might not be covered in the normal course of practical driving tuition. These might include road traffic law, vehicle checks, night driving, responses to emergency situations, hazard detection, search and scan techniques, driving manoeuvres and crash positions etc.

## Instructional methods

A variety of teaching methods are available to driving instructors. Many are intended for group learning situations, but elements of these can often be utilised during in-car tuition.

### The lecture

The lecture is the most formal of all the teaching methods. It is usually a one-way delivery of information from you to the trainees and can be enhanced with different types of presentation media.

The key advantages of the lecture are the efficient use of your time and the benefits that accrue from the group learning environment. A potential drawback is that lectures often require little student involvement. You should design your lectures to maximise class activity and participation. This can be achieved with frequent questions and answers, quizzes, exercises and open discussions. Make sure class control is maintained, however, and that everyone has the opportunity to be involved.

### Case studies

Case studies can be excellent learning vehicles for teaching and discussing events like driver management in emergency driving situations, or crash reconstruction that would normally not be able to be practiced in a car. A case study is a 'What went wrong?' analysis of how a problem could have been avoided or, at least,

managed to reduce risk. Well written, relevant case studies, used with individuals or in group situations with three or four students, offer an alternative teaching method that can be the next best thing to first-hand experience.

#### □ Discussion

A well planned and executed discussion can be a valuable learning experience. To gain the most benefit from a discussion, the learners must have something to contribute. A poorly organised discussion, with little or no input from the trainees, is not, in fact, a discussion. Consider giving trainees a theme or situation to consider for discussion at a later stage.

A potential problem is the difficulty in encouraging all group members to take part. Some trainees will talk incessantly. Others will be noticeably quiet and you must manage the discussion by encouraging these trainees to become involved, perhaps by deflecting the comments of others or with prompts and questions.

#### □ Role play

For some participants, role plays can be a powerful teaching method. Role plays are a learning situation in which students act out the identity of someone else, learning to look at a situation from the other's point of view. While of limited use in driver training, this method of getting a message across might be used when discussing road rage, preparing trainees for licence testing or teaching the 'ins and outs' of purchasing a motor vehicle.

#### □ Simulation

Simulations provide practical driving experiences under controlled conditions where the situation presented by the instructor might be too dangerous or impractical in real time. Simulations can be as simple as sitting in a stationary manual car practicing hand and foot co-ordination to change gear, or as advanced as a computerised simulator that imitates a real driving environment, with all vehicle controls, and which can be managed by the instructor to simulate emergency situations, much as a flight simulator does for pilots.

#### □ Observation

Observation, as a teaching method, particularly the observation of other drivers, can be very effective in situations where you need the trainee, or trainees, to understand the application of correct techniques in, or appreciate the risks of, a particular driving environment. These might include intersections, busy shopping areas, outside schools, corners on the open road etc. You must ensure, however, that trainees are not put at risk and are positioned so that they do not, themselves, become an unnecessary distraction for other drivers.

#### □ Explanation and demonstration

These are the foundation of all practical driver training lessons. Everything you want the trainee to do must be explained and demonstrated first and then, where necessary, demonstrated again in stages. This is then followed by student practice. You must ensure you have the requisite skills and knowledge so that the demonstrations are professional, correct in all detail and explanations are easily understood.

#### □ Discovery

Discovery learning is a general teaching strategy that can be incorporated into all of the different types of learning events. It involves creating the conditions and/or experiences from which trainees can arrive at the correct conclusions themselves. This technique is much more efficient than simply 'telling'. Properly integrated discoveries remain with a student, often for a lifetime.

#### □ Home study

Home study for a driver trainee, depending on experience and progress, can consist of both book study and the practical application of lessons learned albeit, in the case of young drivers, in a supervised environment.

Part of your role is to organise and issue home study tasks that will reinforce lessons already learned and encourage consistency in both knowledge and skills. It can be particularly beneficial if the trainee is to undergo licence testing.

The Road Code is a key tool in the development of driver knowledge but is often neglected once a driver licence has been attained. This is a key reason for home tutored drivers often being deficient in accurate interpretations of the road rules. Parents, taught by grandparents, can pass on generations of misinterpretations and misunderstandings that are all too obvious in driver behaviour and reactions out on the road. A little, often, is a good way to study and remember the Road Code. Study that relates to the driver

training programme will have the most impact and be remembered by the trainee most effectively.

Asking questions that relate to the road rules helps reinforce the importance of staying on top of the Road Code.

Remember that some trainees may have difficulty with reading and will require some assistance. This might require you to discuss ways of dealing with this with the trainee's sponsor – most often a parent. The trainee must not feel disadvantaged and should not be embarrassed by any such difficulties. These learners just need a little more attention and consideration than most others – all part of your role.

## Learning aids

Learning aids are any type of media driving instructors can devise and use that will assist with the presentation of ideas, knowledge and skills so that they can be more easily understood by the learner. They assist the learning process by holding the learner's attention, generating interest, and stimulating the desire to learn. Most teachers know that 'the learning aid liberates instructors from the limitations of their own voices'. They can make a good instructor better but they do not compensate for poor instruction.

Learning aids can range from a notepaper and pencil to sophisticated driving simulators. In between there are a range of aids available to you, many of which can be adapted for in-car tuition.

It is impractical, for obvious reasons, to use a data projector in a car, but a photograph or diagram is a good substitute. A prepared folder of these can be a very good alternative to electronic media although the increase in portable computerised displays offers further alternatives, when used at the right times of course!.

### Learning aids in the classroom

Used carefully, media and visual aids will increase the impact of any training approach and improve the learning experience. Remember, however, that like anything used in training, too much of a good thing can be counter-productive.

There are some general guidelines for using visual aids:

- You must familiarise yourself with the presentation before using it. Familiarity eliminates many potential problems.
- Don't use a visual aid unless it is concise and readable from the back of the classroom.
- If you feel the need to make an excuse for a poor visual aid, you shouldn't have used it.
- Don't be afraid to skip the use of some media you have prepared. 'Read' the class to determine if it will add value or is still relevant and to see if you have enough time.
- Be prepared for problems with equipment by having an alternate plan, If the data show fails, for example, make sure you have a copy of the presentation as a back-up.
- Remember you are presenting to your trainees, not the visual aid. Keep your attention on the learners by making frequent eye contact and positioning yourself to face them. Move around the room while you are talking, if this helps, but make sure you are not blocking anyone's view.

### *Simulator*

Simulators can be quite simple or extremely complex. In their simplest form they can be useful for learning basic skills and at a much more advanced level can play an important part in identifying individual perceptual or manipulative deficiencies and in the development of safety strategies relating to fatigue, ergonomics and road design. The best simulators can only substitute for the real experience but can be useful for settling nervous students.

The main disadvantage of simulators is cost effectiveness. While a chair and a broom stick to practice double-clutching in a truck cost very little, most simulators are very expensive and require a large trainee driver market to justify the cost.

### *Film/video*

For a film or video to be effective it must address the issues at hand. With the advent of data projectors it is a relatively simple matter to upload (or download) appropriate video clips as part of a presentation. Where this isn't possible, make sure the film or video is prepared in advance so that only the relevant sections are screened. Use the counters on the player to assist with this. A summary of the clip, focusing on the relevance to the lesson, should immediately follow the screening.

### *Cameras*

The availability of digital still and movie cameras opens up a whole new avenue of available resources. Traffic scenes can be filmed or photographed for in-class and even in-vehicle use. The images can be incorporated into data shows, used in case studies or applied into presentations on road traffic law. The use of these cameras to produce evidence of trainee performance is not, in most situations, recommended as it offers a distraction that most learners can do without.

### *Data projector*

Modern data projectors, most often linked to lap top computers, are probably the most common form of presentation media and offer a huge range of options. Slides and images can be used either singly or in a progressive sequence to meet a wide range of teaching needs. Some tuition might be necessary for those not familiar with the technology but the potential makes this well worthwhile. Like most modern learning aids there is a potential downside however. What happens if the power goes off or there is an equipment malfunction? You must know your subject, so that if the presentation media goes down, you can continue your presentation verbally and with the basic tools of whiteboard and marker.

### *Overhead projector*

Overhead projectors continue to be a versatile, but increasingly less common, learning aid. Transparencies can be pre-prepared or, with a marker pen, used as a blackboard with the image projected onto a screen. Printed matter can be easily and cheaply photocopied onto slides but care must be taken to protect these as they are prone to scratching and will need to be replaced from time to time.

### *Magnetic board*

Magnetic boards, a derivative of the white board, can usually be used as both a white board and as a magnetic board. Streets and building can be drawn onto the board and magnetised model cars used to illustrate various driving situations.

### *Whiteboard/blackboard*

This remains the mainstay of all instructional tools and the most simple. There will always be a need to write down information for class consumption. Diagrams, lists, formulae, ideas and instructions, relevant to a lesson, all need to be recorded, at least initially, in plain view. Many whiteboards are now electronic and will print off the information contained on the board.

### *Mechanical aids*

Sectionalised mechanical models, or component parts, provide an effective means of explaining basic mechanical principles and how things work. An open gearbox, for example, can assist in explaining how gears work. Engine, clutch and brake components are useful for explaining why drivers do things in a particular way.

### *Tuition vehicle*

The training vehicle, be it car or truck, must be in first class mechanical condition. It might be a driving school vehicle or the trainee's own vehicle but remember a vehicle in poor condition results in a poor learning environment. The importance of vehicle maintenance and servicing must be apparent to the trainee from the very first driving lesson. The vehicle must have a current warrant or certificate of fitness and be maintained to at least that standard. For reliability, it should be regularly serviced and the interior should be kept at a comfortable temperature and have adequate ventilation. Windows and mirrors should be undamaged and clean and additional mirrors should be fitted for the instructor's use.

Some driving instructors use dual control cars for instruction. These allow you to over-ride the trainee's control of the footbrake and/or clutch and accelerator.

#### *Printed matter*

The use of printed material to assist with instruction should not be written off but is really limited to course notes, driver licensing documents and study publications such as *The official New Zealand road code* (road code). *Factsheets* and articles produced by the NZ Transport Agency provide a wide range of information of interest to learners. Topical material sourced from newspapers, magazines or the internet can stimulate interest and are useful to initiate and sustain discussion.

#### *Laminated diagrams*

This type of diagram, used in conjunction with non-permanent marker pens, is very useful for in-car tuition. The diagrams generally display different types of intersections and can be used to demonstrate manoeuvres and road positions and to clarify explanations relating to these.

Note: a selection of blank road layouts are contained in the back of this manual. You may choose to laminate these pages for use during training to enhance your lesson delivery.

#### *Home-made aids*

Some of the best aids instructors can use are those they make themselves. Pre-printed notes or diagrams for supplementary homework or study can be produced easily and quickly.

Make sure spelling is correct and for the sake of clarity, avoid unnecessary detail. Keep it simple, tidy, and professional. Highlight the main points and be sure to link any diagrams to the text.

## Section 3: Analysing training needs/driving assessment/training objectives

### Analysing training needs

The instructor's first role in learning is to establish the trainee's current level of competency so individual training needs can be identified and addressed.

With experienced drivers you must remember not to teach what they already know so you need to determine their current skills and knowledge. A training plan is then prepared and progress charts implemented that assist you in monitoring the trainee's progress.

Trainees will fall into two general categories:

1. Those who have little or no driving experience and are, quite literally, learning to drive. A needs analysis cannot, realistically, be conducted as the learner has no skills, and probably very little relevant knowledge upon which to base a competency decision. These trainees would participate in a planned, structured and fairly regimented programme of instruction. At the completion of training, however, these drivers should undergo a driving assessment to identify if there are any outstanding training deficiencies.
2. Those who have varying degrees of driving experience and are up-skilling or undergoing remedial training due to court orders, employment obligations, parental direction or by personal choice. These trainees can be practically and theoretically assessed to identify current competency and areas of potential risk.

The driving assessment is the ideal tool to measure trainee competency, at different stages, for both groups.

#### Summary

A training needs analysis:

- establishes a trainee's current level of competency through discussion, asking questions and/or conducting a driving assessment
- identifies training needs
- assists in developing appropriate training plans (training plans are covered in section 4).

### Driving assessment

#### Assessment route

A driving assessment is neither a lesson nor a test. It is a drive of no less than 40 minutes (and no more than 60 minutes) during which the driver's interaction with other road users, in a variety of traffic situations is observed, and recorded, for later analysis.

40 minutes is the optimum duration for the assessment as it provides a timeframe during which drivers will lapse into their normal driving behaviours allowing for a more meaningful assessment of their driving skills and behaviour. It is frequently evident that for a period of about 20 minutes drivers can focus on displaying the desired skills before relaxing in the second half of the drive, and allowing normal driving behaviours to emerge.

The route will be pre-planned and should be used for all similar assessments. This allows you to compare individual outcomes and, perhaps, identify common errors and deficiencies within a group of trainees.

The assessment route must reflect the full range of local driving conditions and should include suburban and highway and/or motorway driving with at least 20 minutes of total time spent in city/town centres with medium to heavy traffic conditions. The driver must be exposed to all seven of the driving manoeuvres during the assessment drive.

By meeting this criteria there will be some assurance that the assessment route has sufficient observable situations to which the trainee must apply appropriate driving skills and because those skills must be repeatedly applied throughout the assessment, the level of consistency can be observed.

In areas of high traffic density that severely restrict the distance (and situations) that can be covered, the assessment duration should be extended beyond the 40 minute guideline in order to provide you with sufficient information to determine the trainee's competency in the various driving tasks. Remember however that the duration should not exceed 60 minutes.

## The assessment report

The purpose of the assessment report is to identify the current level of competency of the driver in three skill sets that relate to hazard identification, the use of vehicle controls and road craft.

Note that the skill set for road craft includes both the ability to display prudent and courteous driving practices when interacting with other road users and also comply with driving requirements specified in law.

The skill sets are highlighted across the top of the assessment sheet.

Each skill set is then broken down into the appropriate individual driving skills required within that skill set.

The seven driving manoeuvre categories are shown down the left hand column and represent the manoeuvres that trainee's are required to complete during the assessment.

These manoeuvres reflect individual traffic situations that all drivers have to contend with on a regular basis and which are key considerations when designing training objectives and lessons.

At the end of the assessment performance under each individual driving skill will be cross referenced to the seven driving manoeuvres so that deficiencies can be more precisely identified and analysed.

This information will form the basis of the trainee debrief and the development of any subsequent training plan to remedy faults identified.

Drivers will be considered 'competent' when they can consistently apply the skill sets to all seven driving manoeuvres.

### Driving assessment form

Name:

Assessment date:

Time:

Moving	Hazard identification				Controls			Road craft					Moving
	Applies 12-sec search	Mirror use	Scanning	Applies 2 & 4-sec rule	Power & velocity	Steering & guiding	Slowing & stopping	Lane use	Road position	Signals	Give way rules, controls & signs	Speed limits	
IN													IN
comments													comments
ON													ON
comments													comments
WITH													WITH
comments													comments
THRU													THRU
comments													comments
PAST													PAST
comments													comments
BACK													BACK
comments													comments
OUT													OUT
comments													comments

## Definition of terms

An understanding of the key terms used in the driving assessment is essential for correct application and analysis. The following definitions provide an overview and explanation of the headings.

### The seven driving manoeuvres

- Moving into the traffic (IN)  
Moving into the traffic means joining the traffic flow. This may occur when changing from one lane to another and merging with traffic in the other lane, when entering from a side road or vehicle entrance, when moving off from the side of the road and when using a motorway on ramp.
- Moving on the road (ON)  
Moving on the road means keeping the vehicle safely in the right place on the road without the presence of other vehicles travelling in close proximity in the same direction. Driver actions and responses will not be influenced by other road users, except perhaps by oncoming traffic. Moving on includes changing lanes (but not merging with other traffic), cornering, driving generally and handling emergencies.
- Moving with the traffic flow (WITH)  
Moving with the traffic flow relates to driving the vehicle in close proximity to other road users. This will include vehicles behind, vehicles ahead and vehicles alongside. Traffic includes all road users including cyclists and pedestrians.
- Moving through traffic (THRU)  
Moving through traffic refers to moving the vehicle through situations and potential hazards where other traffic may cross your path. It includes all intersections (including roundabouts), road works, pedestrian crossings, railway crossings, and any situations where enforcement officers may be directing traffic.
- Moving past other traffic (PAST)  
Moving past other traffic relates to vehicles travelling in the same direction at different speeds going past each other safely. It includes moving past or being passed by other vehicles and also includes issues relating to passing parked or stationary vehicles and to passing pedestrians.
- Moving back in traffic (BACK)  
Moving back in traffic means driving the vehicle back along the direction from which it has just come. It includes reversing into parking spaces or vehicle entrances and making 'U' turns or 3 point turns.
- Moving out of the traffic (OUT)  
Moving out of the traffic means leaving the traffic flow. It includes the use of motorway off-ramps, pulling into parking spaces and turning into driveways or side streets by making left or right turns.

Drivers will always be carrying out at least one of the seven manoeuvres while they are driving.

## Skills assessed

### Hazard identification

- Applies 12-second search:  
This relates to the driver's search pattern along the vehicles intended path. It therefore includes all aspects of the driving scene to the front of the vehicle.  
The driver must demonstrate a search pattern that extends out to 12 seconds ahead of the vehicle. Whether this is being achieved will generally be reflected in how early the driver responds to potential hazards or prepares the vehicle for a manoeuvre. Therefore a fault identified in relation to the 12-second search will usually be identified from the drivers performance in reacting (or in some cases not-reacting at all) to potential hazards.  
Remember, 12 seconds on the open road is about 320 metres, and around town about two blocks.  
Any overtaking manoeuvres carried out during the assessment must also meet the requirements of the

12-second rule.

A common result of not applying the 12-second search is low aim steering (see steering and guiding).

□ Mirror use

The frequency and timing of mirror use is an important aspect of hazard identification in all seven driving manoeuvres. Mirrors should be checked prior to and after; turning, changing lanes, pulling out or returning to the kerb, stopping or slowing down and at least every 5–10 seconds in general driving.

Driving conditions may also influence the frequency of mirror use.

□ Scanning

Adequate scanning is accomplished by moving the eyes frequently and avoiding a fixed stare. This involves constantly scanning ahead and to the sides of the vehicle (including intersections) to identify any potential or actual hazards.

Scanning also includes checking blind spots (head checks) by physically turning your head (looking over your shoulder) prior to; leaving the kerb, parking, turning (if necessary) changing lanes, or merging with other traffic.

The use of additional mirrors, by the instructor, will assist in assessing a trainee's search pattern in mirror use and scanning.

□ Applies 2 and 4-second rules

Correct following distances must be applied at all times during the drive.

While the 2-second rule is the normal following distance applied when driving a car, there may be occasions where the 4-second rule is more appropriate. This will be the case when being tailgated, when the assessment vehicle is a heavy vehicle, when the condition or type of road surface is sub-standard and when the prevailing weather conditions deteriorate.

### Controls (manipulative skills)

To maintain control of a vehicle, a driver should understand its performance capabilities and limitations. To make the necessary judgements and decisions in driving, the driver must know what the vehicle can and can't do under various driving conditions. Similar knowledge is also required when predicting the possible movement of other vehicles, particularly motorcycles, modified cars and trucks. Consider the effects of acceleration, directional control, and braking.

□ Power and velocity

Assessment of this aspect of vehicle control includes the regulation of power and speed and the general use of the accelerator, without unnecessary acceleration.

It also includes the use of the transmission, the selection of the correct gear for both engine and road speeds and the way in which gear changing is affected.

A key consideration relates to the application of an appropriate speed for the driving conditions.

□ Steering and guiding

This refers to the way in which the steering wheel is used to guide the vehicle including correct hand position, both hands on the wheel unless operating other controls and the use of smooth steering movements. If the driver does not look far enough ahead (12 second search) low aim steering may also become apparent.

□ Slowing and stopping

The manipulation of the vehicle controls for slowing and stopping are assessed in this segment. The key assessment points include the smooth and effective use of the clutch (if fitted) foot brake and handbrake (if appropriate). Applying the hand brake at intersections, unless on a grade, is not required but the right foot should be on the foot brake. In automatic cars, look for left foot braking. This is not acceptable. In manual cars, check that the driver doesn't coast in neutral or with the clutch depressed for an excessive distance when coming to a stop.

### Road craft

Road craft means the effective application of driving knowledge and skills in a manner that reflects an appreciation of the risks associated with driving and their affects on other road users. Throughout the entire

assessment drive, the driver must display prudent and courteous driving practices and comply with all driving requirements specified in law.

Lane use

The driver must, at all times, use the correct lane for the intended path of travel. This includes turning into the correct lane when entering a multi-laned road. Road markings, particularly directional arrows, and road signs must be complied with at all times.

Road position

This relates to both the safe and legal positioning of the vehicle on the road at all times including when turning or changing direction.

You must have consideration to all the factors that might dictate road position (including other road users) especially if turning right off a main road.

Signals

This segment refers to signalling and communicating. The key points include the duration of the signal (must be at least 3 seconds), use of the correct signals at the correct times and in the appropriate places and, where necessary, the cancellation of signals. This skill includes signalling and communicating in situations where it may not be a legal requirement but is appropriate as a courtesy to other road users to avoid confusion.

Give way rules, controls and signs

Drivers must, where necessary, give way to other road users and react to all warning signs, regulatory signs and controls. They must also have regard for information signs that might affect their driving decisions or performance.

Key signs and controls include Give Way and Stop signs, traffic lights, no parking lines and signs, pedestrian crossings, road works, railway crossings etc.

Speed limits

The driver must observe all temporary and permanent speed limits, including those that demand a lesser speed for certain types of vehicle.

Inappropriate speed for the driving conditions (but within legal limits), is addressed under the *power and velocity* segment of the report.

## Conducting the assessment

Prior to the assessment you must check both the vehicle and trainee to ensure all legal obligations have been met and that the trainee is ready for the assessment. This includes:

- conducting a vehicle inspection including all documentation (eg vehicle licensing, WoF, RUC if applicable)
- Ensuring L plates are fitted (where necessary)
- Ensuring the driver holds, and is carrying, an appropriate and current driver licence for the class of vehicle
- Ensuring the driver is not under the influence of alcohol or drugs.

If any issues are identified from these checks, the assessment must be aborted.

All driver details must be recorded and the candidate briefed as to the intent and format of the assessment.

For example, 'This assessment drive will take approximately 40 minutes and will finish with a debrief of the drive. I will give you directions regarding the route I wish you to take but, as the driver, you will be expected to make all of the driving decisions yourself. Please be aware that I will be making some notes and will discuss these with you on completion of the drive'.

During the drive you must not:

- provide cues or prompts
- provide coaching or training
- provide feedback on performance

- talk unnecessarily.

Directions provided to the candidate must be:

- timely
- accurate
- specific
- clearly understood.

During the assessment all observations must be recorded in an unobtrusive and systematic manner. You must identify any driving errors made during the assessment and record these on the *Driver assessment report*. The completed driver assessment report should provide an accurate and comprehensive baseline for determining discrepancies between actual driving and the required driving standard.

You must endeavour not to 'over-assess' the candidate, but should view each driving task or response in the context of the driving conditions at the time. The intention is not to record a myriad of very minor and isolated faults, but to identify patterns of errors that have the potential to increase risk.

On completion of the assessment drive, you must analyse the assessment report for any adverse driving patterns.

A debrief will then take place with the trainee (usually while still in the vehicle) to discuss their performance during the assessment. If faults have been identified you should start the debrief by commenting on the things they have done well before conveying the faults. This should be done in a positive manner that fuels the trainee's desire to 'get it right'. Any faults identified must also be supported by solutions to address those deficiencies.

This will then result in a training plan being developed to suit the specific needs of the trainee.

## Making decisions and judgements

When conducting an assessment, there are a series of questions you can use to assist in making decisions and judgements on the driver's performance. When the driver is not demonstrating the required level of competency, you should ask yourself these questions:

- Why do I think there is a performance problem?
- What behaviour, or lack of behaviour, have I observed?
- What is the difference between what is being done and what should be done? Is this difference important?

The answers will also assist in deciding where to mark the form. During the early stages of conducting these assessments, it might be a good idea to have the questions on a small card attached to your clipboard or folder.

Safety is paramount at all times and should any of the following situations occur, you must terminate the assessment:

- Trainee drives in a manner that is careless, reckless, or dangerous.
- Trainee commits a serious breach of the traffic law.
- Trainee is involved in a crash.
- You have to take control of the vehicle.
- Any other situation where you consider yourself or other road users to be at risk (including excessive speed).

## Marking the assessment sheet

As the assessment progresses you may notice various skill deficiencies on the part of the trainee. Each time one is noted, put a cross in the relevant box for whichever manoeuvre was being carried out at that time.

You need not record any more than three crosses in any one box as this number establishes a clear pattern of faults for that particular skill.

You will also notice that there is a space for comments in each segment. Use this to record reminders for yourself (eg location and description of the fault or brief notes on the trainee's performance). This can be done in the form of symbols or abbreviations so long as the notes enable you to remember the particular events. These notes will provide a working document which accurately gives you a picture of the driver's performance. By the end of the assessment this will give you enough detail to be able to debrief the trainee (or another person) on their performance and most importantly will also allow you to determine the training needs and develop a training plan to address any faults.

While only faults in performance are recorded on the assessment sheet, a general note should be taken of any skills that were applied particularly well by the candidate. These can be used during the debrief to provide positive feedback to offset the faults that must also be discussed.

It is possible that a fault recorded under one skill set may also result in a second consequential fault under another skill set (ie the outcome of not performing the first driving skill). For example, an error observed whilst slowing and stopping (sudden braking) or steering and guiding (swerving) could have resulted from a skill deficiency in other areas, eg following distances, scanning or 12-second search.

It is therefore possible that drivers who are not competent in the hazard identification skill set could also display deficiencies in controlling the vehicle.

While the marking sheet takes a little time to become familiar with, you need only ask yourself, 'What did the driver do wrong?' and 'In what manoeuvre did the fault occur?' This will help you to identify where to place the cross. Remember a fault can relate to more than one skill deficiency, especially if it is a manipulative error.

If you think you missed one fault while recording another, don't be concerned. Remember, one fault does not constitute a problem and if there is an issue the fault missed will be repeated.

Example 1: When making a lane change (moving into another traffic stream), a driver fails to check over his shoulder (head check) and fails to indicate (signal). In marking the assessment sheet you would place a cross in the boxes for 'Scanning' and 'Signals' in the 'IN' column.

Note: the use of abbreviations (LC) to indicate the faults occurred when performing a lane change. If the assessment route requires a number of lane changes to be performed you may also want to identify the location of the lane change. This information is useful for the debrief as it allows the trainee to relate to the actual manoeuvre concerned. In example 1 the faults occurred when performing a lane change in Smith Street. An alternative to written abbreviations would be to use small symbols.

**DRIVING ASSESSMENT**

Name:

Assessment Date:

Time:

		Hazard Identification				Controls			Road Craft						
Moving		Applies 12 sec search	Mirror use	Scanning	Applies 2 & 4 sec rule	Power & velocity	Steering & guiding	Slowing & stopping	Lane use	Road position	Signals	Give Way rules, Controls & signs	Speed limits	Moving	
<b>IN</b>				X							X			<b>IN</b>	
comments				HC - LC Smith St							LC - Nil Smith St			comments	
<b>ON</b>														<b>ON</b>	
comments														comments	
<b>WITH</b>														<b>WITH</b>	
comments														comments	
<b>THRU</b>														<b>THRU</b>	
comments														comments	
<b>PAST</b>														<b>PAST</b>	
comments														comments	
<b>BACK</b>														<b>BACK</b>	
comments														comments	
<b>OUT</b>														<b>OUT</b>	
comments														comments	

Example 2: On three separate occasions the driver exceeds the posted speed limit when travelling on the open road (without any other traffic in close proximity). A cross will be placed each time the speed is exceeded in the 'Speed limits' box under 'ON'. Note the information beside each of the faults: 105km in 100km zone x 2 and 110km in a 100km zone.

Other faults included in this example are:

- turning into the wrong lane when turning onto a multi-laned road (Lane use/Thru)
- following too closely (Applies 2/4-sec rule/With)
- not scanning through intersections on two separate occasions (Scanning/Thru)
- failing to signal off a roundabout (Signals/Thru).

**DRIVING ASSESSMENT**

Name:

Assessment Date:

Time:

Moving	Hazard Identification				Controls			Road Craft					Moving
	Applies 12 sec search	Mirror use	Scanning	Applies 2 & 4 sec rule	Power & velocity	Steering & guiding	Slowing & stopping	Lane use	Road position	Signals	Give Way rules, Controls & signs	Speed limits	
<b>IN</b>													<b>IN</b>
comments													comments
<b>ON</b>												X X X	<b>ON</b>
comments												105/100 x 2 110/100	comments
<b>WITH</b>				X									<b>WITH</b>
comments				Kid with beams									comments
<b>THRU</b>			X X					X		X			<b>THRU</b>
comments			Field/Power with/center					me - Sony Platt		Am Corp Nissan/Plan			comments
<b>PAST</b>													<b>PAST</b>
comments													comments
<b>BACK</b>													<b>BACK</b>
comments													comments
<b>OUT</b>													<b>OUT</b>
comments													comments

Example 3: The driver continues past school children playing with a ball on the side of the road without altering speed. The speed is within the posted speed limit but is not appropriate for conditions (Power & Velocity/Past). Unless a response like late braking was apparent (indicating a failure to search ahead), the Applies 12-second search box would not need to be marked.

In this example the driver also performs a u-turn and the following faults are noted:

- Fails to check blind spot with a head check (Scanning/Back).
- Fails to signal (Signals/Back).
- Poor steering resulting in manoeuvre being unable to be completed in one movement (Steering & Guiding/Back).

Where faults are inter-related (as with the u-turn above), consider using a line to join the crosses across the sheet. Remember, what immediately comes to mind in the assessment vehicle can become more difficult to recall once the drive has been completed.

**DRIVING ASSESSMENT**

Name: \_\_\_\_\_ Assessment Date: \_\_\_\_\_ Time: \_\_\_\_\_

Moving	Hazard Identification				Controls			Road Craft					Moving	
	Applies 12 sec search	Mirror use	Scanning	Applies 2 & 4 sec rule	Power & velocity	Steering & guiding	Slowing & stopping	Lane use	Road position	Signals	Give Way rules, Controls & signs	Speed limits		
IN														IN
comments														comments
ON														ON
comments														comments
WITH														WITH
comments														comments
THRU														THRU
comments														comments
PAST					X									PAST
comments					X AP-12									comments
BACK			X			X				X				BACK
comments			X U-Turn HC			X U-Turn				X U-Turn NIL				comments
OUT														OUT
comments														comments

At the completion of the assessment, the form must be checked to ensure all the details of the driver and the drive have been collected and then it must be analysed so that training needs can be identified and training objectives prepared.

## Analysing the assessment sheet

### Identifying patterns

In analysing the assessment sheet you are looking for patterns of faults. A pattern of faults is established (and training needs identified) when:

- i. three faults are recorded in any one box or three or more faults recorded in any vertical (downwards) column.  
 In analysing these faults the corresponding horizontal (sideways) column will provide confirmation of the manoeuvre being undertaken when the faults occurred. This will provide information on where training should be conducted, or

- ii. three or more faults are recorded in any horizontal (sideways) column that relate to one specific driving manoeuvre within that category. For example three or more different faults (scanning, steering, signals) were identified when performing a u-turn (Back).

Note: While the main focus is on patterns of faults, you must consider the significance of any isolated faults (that have not resulted in a pattern) and make a judgement as to whether the fault needs to be addressed in some form. Depending on the situation this may be achieved by discussion with the trainee during the de brief, or if appropriate through remedial training.

In making this judgement you should also be mindful that on some assessment routes it may not be possible to repeat a particular driving task to determine if a skill is consistently not being performed to the required standard. An example could be not searching a railway crossing where the assessment route does not provide an opportunity to repeat the task to establish if the trainee is consistently not applying this skill.

DRIVING ASSESSMENT													
Name:		Assessment Date:					Time:						
Moving	Hazard Identification			Controls			Road Craft					Moving	
	Applies 12 sec search	Mirror use	Scanning	Applies 2 & 4 sec rule	Power & velocity	Steering & guiding	Slowing & stopping	Lane use	Road position	Signals	Give Way rules, Controls & signs		Speed limits
IN			X MC - LC Smile/Plt							X LC - MC Smile/Plt			IN
comments													comments
ON												X X X	ON
comments												105/100 X 2 110/100	comments
WITH				X Red Van Darius									WITH
comments													comments
THRU			X X P12/Power Smile/Plt					X MC - Smiley Plt		X R/Coff MC/Smiley/Plt			THRU
comments													comments
PAST					X MC - D								PAST
comments													comments
BACK			X U-Turn MC			X U-Turn				X U-Turn MC			BACK
comments													comments
OUT													OUT
comments													comments

The assessment sheet above incorporates all the faults recorded in the three examples used previously above (under the section 'marking the assessment sheet').

In analysing the faults recorded you will see that patterns have been identified in the following skills:

- Scanning.
- Signals.
- Speed limits.

In checking the horizontal (sideways) columns you will also see that a pattern has been identified when performing the following specific manoeuvre:

- U-turn.

## Analysing fault patterns

The skills shown in the table below reflect the patterns of faults (three or more) identified in the assessment report above. In terms of setting training objectives the following lesson plans (contained in section 6 of this manual) could be considered. When considering the lesson plans, the nature of the fault should be considered and the relevant learning points from the lesson plan utilised to rectify the fault.

Skill	Training objectives that could be considered	Manoeuvre	Where is training to be conducted
Scanning	Hazards & system of vehicle control (9)	In Thru Back	Changing lanes/moving through intersections/ u-turns
Signals	Signals (6)	In Thru Back	Changing lanes / moving through roundabouts/u-turns
Speed limits	Rural/open road driving (17)	On	Travelling on rural or roads with higher limits
U-turns	U-turns & three-point turns (22)	Back	Performing u-turns

### Self-check exercise

Below is a scenario for you to practice recording faults found during a driving assessment. Transcribe the faults listed onto the blank assessment report that follows. Once the faults are recorded see if you can identify any pattern(s) that may require training to rectify.

- Pulls out from kerb into a heavy traffic flow. In doing so the driver did not check the blind spot (head check) and did not look in the mirrors. Also failed to signal.
- Changes lanes without signalling.
- Follows the car in front too closely.
- Fails to signal when turning left at a give way controlled intersection.
- Travels at 110km/h in a 100km/h zone with no other traffic around.
- Comes up to well sign posted road works with a speed restriction of 30km/h. Does not lower speed until right on scene of road works and continues travelling at 40km/h through roadworks.
- Leaves road works and continues on suddenly swerves to pass a cyclist who has been clearly visible ahead for about 400 metres.
- Asked to complete a three-point turn. Indicates, checks mirrors but fails to complete a head check before commencing the manoeuvre. Accelerates quickly throwing you against the passenger door.
- When turning left at an uncontrolled intersection accelerates too fast causing the vehicle to drift over the centre line.

# Driving assessment

Name:

Assessment date:

Time:

Moving	Hazard identification				Controls			Road craft					Moving
	Applies 12-sec search	Mirror use	Scanning	Applies 2 & 4-sec rule	Power & velocity	Steering & guiding	Slowing & stopping	Lane use	Road position	Signals	Give way rules, controls & signs	Speed limits	
IN													IN
comments													comments
ON													ON
comments													comments
WITH													WITH
comments													comments
THRU													THRU
comments													comments
PAST													PAST
comments													comments
BACK													BACK
comments													comments
OUT													OUT
comments													comments

DRIVING ASSESSMENT													
Name:		Assessment Date:					Time:						
Hazard Identification			Controls				Road Craft						
Moving	Applies 12-sec search	Mirror use	Scanning	Applies 2 & 4 sec rule	Power & velocity	Steering & stability	Shifting & stopping	Line use	Road position	Signals	Give Way rules, Cones & signs	Speed limits	Moving
IN	X	X	X							X			IN
Comments		Kerb	HC-Kerb							Kerb L.C.			Comments
ON													ON
Comments													Comments
WITH			X										WITH
Comments													Comments
THRU	X				X				X	X			THRU
Comments	Roadworks												Comments
PAST	X					X							PAST
Comments	Cyclist					Cyclist							Comments
BACK			X		X								BACK
Comments			3PT		3PT								Comments
OUT													OUT
Comments													Comments

In this scenario the faults found during the driving assessment (as above) would indicate two clear patterns that would require retraining:

- Signal use (three faults in the vertical column).
- Pulling out from the kerb (moving in), ie there are three faults relating to this one specific manoeuvre.

In developing a remedial training plan the following lesson plans could be considered:

- Signals (6).
- Moving off and stopping – at an angle (5).

While not patterns, other issues that could be discussed during the debrief include: application of 12-second search, harsh acceleration, mirror use and speed limits (particularly in relation to negotiating roadworks).

## Writing training objectives

Training objectives are the cornerstone of all training. If the learner and the instructor know where they are going (what is to be learned and to what standard), then they will both know when they reach that destination (achieve their objectives). If the trainee knows how they are progressing through the lessons they will be stimulated by that success.

Never neglect the objective setting process.

A training objective states what must be achieved by a trainee, with what and to what standard. It is phrased in terms of observable behaviour and has three parts.

A performance statement: 'The trainee will demonstrate the ability to negotiate an intersection ...'

You select the performance for each objective. These performances could include, for example, parking a car, moving off at an angle, negotiating an intersection or changing a wheel.

The information contained in the conditions and performance statements assists you in determining the training route, or ground, for the specific skills to be taught and assessed.

A standard statement: A standard statement states how well a trainee must demonstrate a skill or complete an activity – '...in three out of three trials, while applying all legal obligations and the system of car control and without interfering with other road users.'

Performance standards might also include times, number of repetitions or statements of accuracy.

A condition statement: '...given a car with a manual transmission, on a public road, in daylight'.

These are the conditions under which trainee will be expected to demonstrate their competence. The conditions of a training objective set out the resources and environmental considerations that must be available to the trainee when the assessment of the objective is conducted.

In the example above, the student must have a car with a manual transmission and the evaluation must take place on a public road in daylight. The conditions will reflect the intent of the training.

Performance objectives form part of everyday life. The mother who tells a child – 'I want you to have your bed made and room cleaned so that it is spotless by 10 o'clock or you won't be going out this weekend. You'll find the vacuum cleaner in the cupboard and clean sheets in the laundry' is, in fact using performance standards and some condition statements in her instructions.

The employer who asks an employee to take a company vehicle and, without crashing it, get to the airport to meet a specified flight, pick up a client and return to the office by a stated time, is also using a performance objective, albeit a fairly simplistic one.

While section 6 in this manual contains a wide range of individual lesson plans (which are based around specific training objectives) covering the competencies required to drive a car, remember to develop your own training objectives when preparing lessons that are not covered in section 6.

## Section 4: Conducting practical instruction

Trainees taking driving lessons are usually motivated to learn. They are alert, willing to follow instructions and anticipating each lesson. The initial enthusiasm, however, may not last for the whole programme unless it is fostered by the instructor. An important part of your work is to help students through difficult periods with unconditional positive responses to them and their work. Interest is stimulated by success. Small successes are important to trainees who find the learning process difficult. By creating a warm learning environment, you foster this success. Graduating the tuition in short, progressive and attainable steps is the best approach as is encouraging interest and praising trainee effort.

You should set out the objectives at the beginning of each lesson and confirm these with the trainee. In the early stages of instruction, you should set up some easily attainable, short-term objectives for each lesson and encourage and praise trainee effort.

Many practical driving skills are conditioned responses. They require the task to be learned accurately and require repetition to be mastered properly. Only practice ensures that the skill becomes second nature and an established part of the driver's competencies.

In this regard, road safety is no different to any other educational subject in that an extended timeframe is needed for substantive learning to occur and content needs to be repeated to have a lasting effect. In fact, the need for time and repetition may be greater for road safety education because not only are you aiming to impart new knowledge and skills, but just as importantly, you are also seeking to influence motivation and future behaviour.

Knowledge of the road code and skills to manipulate a vehicle in traffic alone are not sufficient to become a safe and competent driver. Training must therefore be based around a whole-of-driver approach where the safe operation of a vehicle also depends on personal decision-making based on attitudes and values.

A valuable resource in teaching young drivers is the publication *Safer young drivers: a guide to best practice education*. This can be downloaded from the NZTA website at [www.nzta.govt.nz/resources/safer-young-drivers/](http://www.nzta.govt.nz/resources/safer-young-drivers/).

### Managing learning

Today, most people engage in only one high-risk, life-threatening activity – driving. At a basic level, driving is relatively simple even though the first lessons a student driver takes require all the concentration and effort the student can muster. Within a relatively short space of time, however, the student becomes more familiar with handling a vehicle and eventually driving becomes routine.

Driving involves the application of a complex set of skills. You must always be aware that the skills and information you teach, or neglect to teach, could in the future have very positive or very serious consequences. For this reason, you must not teach the learner simply to pass the practical driving test nor should you teach solely on the practical test circuit.

The delivery of training for young drivers also needs to incorporate motivational and attitudinal factors.

The matrix below provides an overview of the goals of driver education and a guide to how these elements may be incorporated into training.

	Knowledge and skills a driver has to master	Risk-increasing factors a driver must be aware of and be able to avoid	Self evaluation/assessment
Life goals and life skills	Knowledge about and control over how lifestyle and personal tendencies affect driving behaviour, eg age, group, culture, social circumstances	Knowledge about and control over risks connected with behavioural style, peer pressure, substance abuse, etc	Awareness of personal tendencies regarding motives, impulse control, etc
Goals for and content of driving (trip-related)	Knowledge about the various needs of different trips, eg being able to plan and choose routes, evaluate the necessity of the trip	Understanding the impact of alcohol, fatigue, mood, social context and competing motives, etc	Self evaluation/awareness of personal planning skills, typical goals of driving, typical risky driving motives, etc
Driving in traffic	Mastering traffic rules, hazard perception, safety margins. Automating elements of the driving process. Cooperating with other drivers, etc	Understanding the risks associated with disobeying rules, close following, vulnerable road users and difficult conditions	Self evaluation/awareness of basic traffic skills and skills for hazardous situations, personal driving style. Personal safety margins
Vehicle control	Basic vehicle handling skills, eg braking, shifting gears, keeping the car under control. Knowledge of injury preventative systems such as safety belts and airbags	Understanding risks associated with non-use of safety belts, worn-out tyres, breakdown of vehicle systems, etc	Self evaluation/awareness of strengths and weaknesses regarding basic driving skills, manoeuvring in hazardous situations, etc

The matrix's underlying rationale is that, in real life, factors such as peer pressure, a driver's physical and emotional condition, and personal tendencies (eg being risk-keen) significantly impact on driving behaviour and greatly influence the sorts of driving situations that the driver will be in. To be effective, road safety education for young drivers needs to incorporate these factors.

The development of strong self-evaluation skills in young drivers is a key way of avoiding young people becoming over-confident in their technical driving skills. To avoid this misperception and moreover to ensure training content goes beyond technical skills, the prime aim or goal of any driver educator should be to help equip people with the knowledge, motivations and skills needed to be technically competent and safe drivers. The objective of helping young drivers gain their driver licence should only ever be a secondary goal.

You are the manager of the learning experience, with responsibilities extending beyond the mere act of teaching.

Apart from the quality and content of a series of lessons, your responsibilities range from the planning and organisation of the course to the final assessments at the completion of training. You must have regard for the following:

- Select and prepare learning materials matching the current skills and knowledge of the trainee.
- Organise progressive units of learning to suit the trainee's needs.
- Present skills, techniques and teaching methods that build upon current learner knowledge, planning venues and routes that support the trainee's needs.
- Graduate tuition based on trainee ability and progress.
- Involve trainees in the learning process at every step.
- Reinforce the learning with feedback, periodic evaluation and relevant information.
- Ensure competency at each stage of learning before progressing to the next stage, using revision at the beginning of each lesson.

The key to the successful management of learning is the ability to present, adapt and adjust the same basic knowledge and skills to the wide range of learning abilities of different trainees. You must not only be a master of your craft, but must also have a range of skills and instructional techniques that can be called upon to meet the needs or progress of the learner.

Remember that statistically the greatest risk period for young novice drivers is in the first six months of solo driving, ie in the first six months of gaining a restricted licence.

This suggests that in order to make greater safety gains for young drivers, the focus needs to be on improving the quality and relevance of the training that is delivered during the learner phase. This includes the information that is provided to a young person's driving coach or supervisor.

## Empowering parents and supervisors

In managing and encouraging learning, you must not underestimate the role parents and supervisors play as part of this process.

International best practice recommends that young people gain 120 hours of supervised driving under a wide variety of driving conditions and environments before they start driving solo. Currently in NZ the level of self-reported supervised practice for learner drivers is much lower than this – averaging around 40 hours.

You can help to address this disparity by making sure parents are aware of the best practice standard of 120 hours and the need for their children to experience a wide variety of conditions and environments during this time.

A key challenge for you is to liaise with parents and encourage them to access the information and training they need to be competent supervisors.

You can also help mitigate parental over-confidence by facilitating an effective three-way partnership between yourself, the parent and the young driver. You can do this by giving parents information so they know about the elevated crash risk that their teenagers will face over the first six months of solo driving. Alongside this information, parents also need to be reassured that the best way they can create a safe learning environment for their teenagers is by combining formal driving education with supervised practice.

## Develop a training plan

Once the training needs analysis has been completed, a training plan should be developed that reflects both the trainee's learning needs and their learning capability. The plan should also focus on strengths and weaknesses and be adjusted to reflect progress through the programme or course of instruction. Other considerations include:

- There should be a structured and logical sequence of learning events.
- There should be provision of information for the review of trainee progress and feedback.
- The plan must be confirmed with each trainee.
- The trainee should receive a copy of the plan so that they can record details of all personal practice and training.

## Select and prepare suitable learning material

The information and resources selected for training must be directly related to the trainee's needs and lesson objectives. They should be accurate and reliable. A huge range of learning material is available to driving instructors in books and on the internet.

## Organise progressive units of learning

Course objectives must be organised into short, progressive units of learning. Short-term objectives reinforce learning and provide positive evidence of progress through each training session. Intermediate objectives

stimulate student interest and encourage progress. The main driving tasks have been organised into short progressive units of instruction in section 6 of this manual and have particular relevance to structured training for inexperienced, learner drivers. Remember, driving is a complex task that includes many enabling skills, eg gear changing, observation skills, steering.

## Develop individual lesson plans

Where you have to develop your own lesson plans, perhaps because the needs of the trainee will not be satisfied by the lesson plans in this manual, or because elements of some of these plans need to be consolidated for a lesson, the following points must be addressed:

1. The lesson plan must include a measureable outcome (have performance objectives).
2. It must address the training needs of the individual. If this means having to forego the plans in this manual, so be it.
3. Each lesson plan must include:
  - an objective(s)
  - trainee details
  - prompts for pre-training briefs
  - revision
  - a logical sequence
  - instruction and assessment in stages
  - combined assessment of all stages
  - assessment outcomes
  - points for debrief and feedback
  - space to record feedback from the trainee
  - next lesson.
4. The lesson plan must reflect the instructional concept of explanation, demonstration and practice.
5. It must be prepared in such a way that it can be used by another instructor.
6. The format must be logical and easily used in a driver training environment.
7. It must reflect the requirements of the training plan.
8. It should allow adjustments to be made to align with trainee progress.

## Grade skills and techniques

Using the planned lesson objectives as a guide, each unit of learning should be progressively graded in difficulty so the trainee makes as few mistakes as possible. Initial failure can demoralise the learner and inhibit future progress. Build confidence and understanding upon a foundation of practical skills. Progress from what the student knows and can do, to skills that are new and challenging but remember to master simple skills before attempting more complex ones. Lesson plans should reflect this progressive grading of instruction.

Make sure the training venues and routes reflect the complexity of the lessons and the abilities of the trainees.

## Route planning

Route planning is an important element of lesson preparation for any practical driving instruction. A sound understanding of local driving conditions is necessary and route planning must be based upon the specific needs of each lesson and trainee.

A route which exposes trainees to unnecessary, or unfamiliar, risks can adversely affect the success of the training and the confidence of the trainee. Some trainees will simply be unable to cope with the conditions and

lose all desire to continue with the lessons, seeing the challenges that the instructor has set as being unachievable. Even for other, more confident trainees, the inherent risks increase.

A variety of routes and timings are necessary to cater for the ability of the trainees and as a means of managing exposure to traffic conditions. Some flexibility must apply, however and is important for a number of reasons. Trainees must not become bored with repetition. Each trainee will develop at a different rate and require different degrees of access to progressively more complex driving conditions. Routes can be weather or traffic affected outside accepted seasonal or peak periods.

Training routes generally fall into three categories:

1. Beginner routes.
2. Intermediate routes.
3. Advanced routes.

These routes may overlap and it may be justifiable to incorporate all types into one session for the more advanced trainees or when assessing a driver for competence and/or training needs.

The increasing complexity of driving conditions must be introduced at a controlled rate which meets the trainee's needs and compensates for their lack of ability. In reality, driving conditions can change unexpectedly. A carefully planned route can suddenly become unsuitable if trainees have to face a situation with which they can't cope. Well considered route planning should reduce these situations to isolated events, however. You should always have crisis management plans to deal with all types of emergencies but avoidance, wherever possible, is always the best option.

Training routes are usually a compromise between local geography, the prevailing driving conditions and the needs of the trainee. If you are working in a large city, you may have problems finding suitable beginner venues or routes. If you are working in rural areas, on the other hand, you might have a problem finding suitable advanced routes.

## Beginner routes

Beginner routes include off-road venues such as car parks, industrial and commercial sites and private land. Roads should be selected that have no complex intersections and the very lightest of traffic conditions.

Beginner routes, ideally, should progressively include quiet, wide roads on level ground or with minimal grades, for practising manipulative skills like steering, braking, gear changing and parking without disrupting other road users. Simple intersections with left and right hand turns should be added as manipulative skills improve.

## Intermediate routes

While there may be some overlap between beginner and intermediate routes, the latter should include:

- all types of intersections with give way signs, stop signs and traffic lights
- grades to practice uphill first gear 'hold and control' at intersections
- roundabouts
- roads and streets for practising u-turns, three-point turns and reversing.

Avoid driving test routes during training. Right turns onto busy main streets and roads, multi-laned roads and other very difficult or possibly dangerous situations should be excluded from these routes.

## Advanced routes

Advanced routes should progressively extend the trainee's abilities to cope with variations in the driving conditions, including dual carriageways, multiple lane streets and roads, one-way streets, level crossings, busy shopping streets, and rural roads to practise overtaking. Advanced routes should also include situations similar to those used in the driving test. Include:

- pedestrian crossings – zebra, traffic light controlled
- one-way streets
- level crossings
- multiple lane roads and lane discipline
- dual carriageway
- motorways if possible
- rural roads.

### Summary

When planning and selecting routes for each trainee, consider the following points:

- The level of competence of the trainee.
- The specific skills to be taught.
- The particular hazards to be included or avoided.
- Time available.
- The danger or inconvenience to other road users.
- Nuisance to local residents.
- Excessive repetition of routes bores students.
- Traffic distracts trainees learning basic skills.

## Graduated tuition

To plan an appropriate level of training, establish the trainee's current knowledge and skills. As has already been stated, it is poor teaching practice to teach learners something they already know, unless, of course, they have 'mis-learned' the skill. Trainees should be consulted about their own learning and encouraged to take responsibility for the decisions involving their learning. Considerable variations exist in the rate at which different trainees learn. When giving individual tuition, the training must be tailored to suit the needs and abilities of each trainee. They should work through each unit of learning at their own pace, with new skills and techniques being introduced at a level that matches their current ability, knowledge and previous achievement.

As skills develop and competence in the manipulation of the controls improves, trainees should be informed of what they are doing and why and also how they are doing. Basic skills should be taught as simple conditioned reflex procedures. However, it is more important that trainees respond correctly to an emergency rather than they understand why they should respond in that way. Remember, never leave trainees confused or in doubt.

## Active involvement

The trainee should be kept physically and mentally involved with the learning experience. Whatever they learn will only be achieved by thinking and doing things for themselves. Activity captures the trainee's attention. Observing a learner's physical activity is relatively easy. Observing what they think, however, is more difficult. An active mind is essential to learning, and an extremely important part of driving.

During early learning keep trainee's minds active by asking questions about relevant road rules and the reasons for their actions. Do not, however, distract learners when they are busy. Once the trainee has experienced the learning process for some time, you will play a more passive role, observing the quality of the trainee's work and commenting on it less frequently. This situation provides ideal opportunities for developing the learner's visual search and observation skills along with the reasoning processes of a skilled driver.

## Reinforcing learning

Trainee learning must be reinforced through constructive comments relating to their performance and by providing frequent and ongoing feedback on progress. Feedback on poor performance should occur immediately after the event or manoeuvre to prevent further faults appearing. Be sure to explain any safety issues that might arise from any less than ideal performance.

Comments such as 'Good' or 'Very good' indicate progress when insufficient time exists to offer more detailed information but do not relay anything constructive about actual performance.

Comments such as, 'Our position was slightly too far to the right on the approach to the turn', or 'The gear change was not necessary in that manoeuvre' or 'The speed approaching the intersection is still a bit too fast', are more useful because they provide specific feedback relating to actual performance.

Short comments and corrections made on the move will be valuable in improving learner performance but detailed verbal corrections should be avoided when the vehicle is moving. When required, give detailed comments as soon as is practical after the event, but only when stationary.

Active involvement facilitates learning but, like all other aspects of learning, has to be managed. It does not ensure that the learning is correct or that the trainee is making progress.

## Reduce the likelihood of over-confidence

For trainees who are either over-confident or under-confident in their abilities, you will need to adapt your training strategies accordingly to correct these imbalances.

Over-confidence combined with certain risk factors (such as propensity to risk-seeking and peer pressure) can lead to unsafe driving behaviour.

During training, you can minimise any unintended effects of over-confidence by implementing counter-measures such as encouraging trainees to recognise their own personal limits and to drive within these bounds. This could be achieved by trainee self-evaluation of their strengths and weaknesses and the subsequent impact on their decision-making abilities and driving. Other measures could include keeping training messages simple and clear, and checking for and correcting any unintended messages that may instil over-confidence.

## The sequence of training

The generally accepted sequence for learning and developing a skill is:

- Basic training
  - explanation
  - demonstration
  - controlled practice.
- Developing the skill
  - prompted practice
  - revision
  - increasing complexity
  - transferred responsibility.
- Independence
  - the use of skills in uncontrived (real time) traffic situations.

As the competency of the trainee improves, separate, but integral, skills may be at different stages of development. Training must be based at the correct level for each skill. Similar skills must not be taken for granted. For example, moving off from the kerb is a less complex skill than moving off at a busy uphill intersection.

Prior to practising a new skill, trainees should know why it must be learned and when and where it should be used. They should understand clearly what is expected of them and how each task should be performed. They must also know and understand any technical jargon related to driving instruction and be able to respond quickly, and with confidence, to instructions in the vehicle.

## Basic training

When teaching a skill, the normal sequence of instruction is:

### Explanation

Explanations must be appropriate for the standard and ability of the trainee. During the early stages of learning to drive, don't dwell on the subtleties or detail, but try and establish and consolidate the key points. When the principles are firmly entrenched, the trainee will find it easier to assimilate and apply additional information.

Consider the following aspects of an explanation:

- What the skill is.
- Why it is important.
- When and where it should be carried out.
- How it should be carried out.

Explanations generally consist of three main parts. They include details and information concerning:

- Control:** Explanations should include the use of the vehicle controls and attention to speed when approaching or dealing with hazards. This relates to the manipulative skills needed for driving. For example, hand and foot coordination when moving off, low speed clutch control, smooth, progressive use of the accelerator and transmission, efficient use of the brakes when slowing down and after stopping at an intersection.
- Observation:** Explanations must also include information relating to perceptual skills and hazard identification techniques that are such an important part of driver training and that apply to the particular demonstration. This includes the identification of sight clues and simple methods of minimising potential risk.
- Positioning:** Positioning covers road and lane position, steering, and general accuracy in maintaining the required path of travel. The use of diagrams to clarify an explanation or an observation works very well in this aspect of the explanation.

### Demonstration

Demonstrations have many applications in the training of drivers. They show trainees exactly how a good driver should perform a skill or procedure, they emphasise or reinforce specific sub-skills and they also provide learners with visual information so that subsequent explanations may be better understood.

An explanation should precede any demonstration. The demonstration should then be conducted in its entirety, without commentary, so that the trainee is exposed to the whole process. It should then be demonstrated again, in stages where appropriate, with explanations of the key points as a commentary. The demonstration should then end with a summary of those key points.

- A demonstration must be at the correct level for the ability of the trainee.
- Demonstrations must be professional executions of the relevant skills or procedures, carried out at near normal speed.
- Restrict comments, during demonstrations, to the key points.

### Controlled practice

Driving is a skill that is best learned by 'doing' with the use of practice and application but the instructor must take control of practice sessions right from the start of training. The term 'controlled practice' relates to this

concept. It should take place, at least initially, in a safe, easily controlled environment and involve the trainee following simple verbal instructions to carry out sub-skill sets which, when combined, form a complete skill or procedure.

In the introductory phase the instructor plays a dominant role talking the trainee through all the basic routines and procedures. This might include such things as the location and operation of car controls, basic steering, basic gear changing and moving off and stopping. You only move onto more complex activities once the trainee has demonstrated consistency in all of the basic skills.

While this method is usually successful when introducing trainees to new skills, there are a few points that you need to consider:

- Due to the limitations of verbal communication, the timing of some skills can become a little artificial. You can only issue one instruction at a time. Some skills require coordinated, simultaneous responses and it can, therefore, be very difficult to issue instructions at the exact moment they need to be received by the trainee. Be aware of this limitation but appreciate that if demonstrations and explanations have been applied effectively, and in stages, this problem is almost negated.
- The speed with which learners interpret instructions can cause reaction delays of varying lengths. This should become less of a problem as confidence and skill levels improve.
- No real alternatives to controlled practice in the initial stages of learning really exist and, in reality, are unnecessary. An expensive simulator might seem to be a safe alternative, but it falls well short of the actual driving experience because it lacks many of the sensory aspects of driving, particularly in regards to vehicle movement and speed relative to the ground, dynamic responses to changes in direction and the presence of real hazards with real consequences. Simulators are an option where a specific problem needs to be addressed in a controlled environment.
- Most trainees are very good at following instructions, but many left to perform skills unaided, often can't complete them. Others who find it difficult to follow instructions, for any of a variety of reasons, can advance quite quickly when working under their own initiative. It is up to you to identify the strengths and weaknesses of each individual and tailor their training accordingly.

While controlled practice is an essential part of basic training, it should be phased out as soon as the student demonstrates the ability to consistently apply all the basic driving skills.

## Developing the skill

### Prompted practice

Prompted practice is a natural progression from controlled practice and comes into play once all of the basic skills have been mastered. The trainee is gradually exposed to more complex situations where the basic skills have to be applied consistently but you provide guidance and talk the trainee through each situation or skill as required. The amount of prompting that you provide will depend upon the ability, and willingness, of the trainee to make their own decisions. The types of decisions required are significant because if the driving conditions place excessive pressure on the trainee, they just might make no decisions at all. If this situation arises, you must quickly return to prompting the trainee until driver confidence returns. This is a common, and normal, part of driver instruction. The objective, however, is to have the trainee carry out all the skills under normal driving conditions without any prompting at all.

### Revision

Revision is a key aspect of training, particularly in the early stages of developing new skills and knowledge. An accurate assessment of driving skill cannot be made if the student still requires prompting. Before any new lesson commences, you must ensure that the skills and knowledge arising from the previous lessons have been assimilated and can still be applied. To achieve this, the trainee should be expected to repeat the previous performance before moving onto the new period of instruction. If this isn't achieved, you and the trainee must

revisit the skills and/or knowledge that are deficient and not progress any further until consistency has been demonstrated.

#### Increasing complexity

Once prompted practice has been applied, you should expose the trainee to a range of driving environments that gradually increase the complexity of both the driving conditions and the driver responses to them. The level of complexity should reflect the ability of the trainee and trainee performance must be carefully monitored to ensure they aren't starting to get 'out of their depth'. The challenges of this aspect of training are a key factor in developing driving skills and strategies but every trainee will develop at their own rate. As the complexity of a route increases, the amount of prompting by you should reduce as a result of the improvement in driver skills.

#### Transferred responsibility

As soon as the trainee exhibits sufficient confidence, and you are convinced of the ability of the trainee to consistently apply the requisite skills and knowledge, the trainee should be encouraged to take more responsibility for their own driving decisions and more emphasis should be placed on the development of perceptual and hazard identification skills. This is where confidence is developed and problem solving evolves. When trainees make their own decisions, errors in judgement and the manipulation of controls become apparent and you can then focus on aspects of the trainee's performance that still require attention. The use of questions and answers is useful, at this point, as a means of identifying what the trainee is thinking or how they are conceptualising a problem.

#### Independence

This is the final stage of training where trainees should be continuing to develop perceptual skills and their responses to potential hazards in a systematic manner. The ability to appreciate that other drivers also make mistakes, and make allowances for this, should also become apparent. It is a time for conducting assessments of competence so that both strengths and weaknesses in the trainee's performance can be identified and, where necessary, rectified. Quite simply, it is the point where you state where you want to go, and the trainee takes you there in a safe and competent manner, meeting all legal obligations.

## Terminology and instructions for use with trainee drivers

Instructions given to trainees undergoing practical driver training should be consistent, concise and clearly understood. For example, if, after always referring to the 'accelerator', you change the terminology to 'throttle' or 'gas', the trainee may become confused. If, after using 'indicate' for a period of time, you change the terminology to 'signal', momentary learner hesitation could have potentially serious consequences if driving in heavy traffic. Trainees must recognise and interpret terminology immediately if any instruction is to elicit the correct response promptly.

Trainee unfamiliarity with instructional terminology, or industry jargon, is greatest during the early stages of learning to drive. The same terminology should be applied right through any training programme so that confusion is eliminated and you should try to use terminology that is common across the industry. In this way, trainees moving from one instructor to another are familiar with instructions and terminology.

When introducing trainees to vehicle controls and their functions and use, they must be given time to assimilate unfamiliar words and their meanings. Use terminology that is easily recognised and clearly understood.

#### Basic terminology

The sample of instructions that follow are common and can be used to elicit the required responses from all learners. In most cases, the basic responses can be practised in a stationary car.

##### Clutch

- 'Cover the clutch.'

- 'Clutch in.'
- 'Clutch out slowly.'
- 'Find the holding (or take up) point.'
- 'Hold the clutch steady.'

#### Brake

- 'Cover the brake – get ready to act.'
- 'Squeeze the brake gently.'
- 'Brake harder.'
- 'Release the brake slowly.'
- 'Release the brake.'

#### Accelerator (gas)

- 'Cover the gas (or accelerator).'
- 'Set the engine revs.'
- 'More gas (or accelerate).'
- 'Less gas (or decelerate).'
- 'Off the gas (or accelerator) or 'Ease off slightly'.

#### Steering

- 'Get ready to turn the wheel – left or right.'
- 'Turn the wheel – left or right.'
- 'Hold the wheel correctly.'
- 'Position your hands correctly.'
- 'Relax your shoulders.'
- 'Look up.'

#### Gears

Refer to gears as first, second, third, fourth, fifth, drive, reverse, park and neutral.

- 'Get ready to select gear (but don't take hands off wheel until ready to act).'
- 'Select drive, first...fifth or reverse.'
- 'Check neutral.'

#### Park brake

- 'Park brake on or off.'

#### Indicators

- 'Get ready to signal.'
- 'Signal left or right.'
- 'Cancel signal.'

### Visual search

- 'Check/use the mirror.'
- 'What's happening behind?'
- 'Scan ahead.'
- 'Look into the intersection.'

### Mirrors

- 'Check for following traffic.'
- 'Use the side mirror.'
- 'Do you need to signal?'

### Blind spots

- 'Look over your right/left shoulder.'
- 'Check the blind spot.'

### Intersections

- 'Look right, left, right again.'
- 'Is it safe to proceed?'
- 'Your visibility is restricted – make sure it is safe to proceed.'

With more advanced trainees, prompting has more meaning if instructors ask short questions: 'Is it safe to back up?' 'Is a signal needed?' Cueing forces students to think for themselves and start to take responsibility for their driving.

## Giving instructions

The quality of a driver's performance can be undermined by unclear or late instructions. Trainees must be given sufficient time to both interpret, and react to, instructions and you must remember that inexperienced students will usually take longer to respond.

Instructions must be precise and clear, alerting the trainee, identifying the location where the action is to take place and stating the action required. The timing of the instruction should allow the trainee to assimilate the information, consider the responses and carry out the action or manoeuvre in a safe, unrushed manner.

Most instructions concerning the route contain three necessary components. These are:

- Alert: draw the student's attention to the imminent request.
- Identify: provide a reference for the instruction to be carried out.
- Direct: the instruction pertaining to the performance required.

Examples:

Alert: 'OK John,'

Identify: 'at the next intersection'

Direct: 'we are going to turn right.'

Alert: 'Sally,'

Identify: 'immediately after the parked truck on the left'

Direct: 'we are going to turn left.'

Alert: 'Peta, that last turn was done really well. Now what I would like you to do is,'

Identify: 'at the next roundabout'

Direct: 'take the second exit and, when it is safe to do so, pull over and stop.'

Alert: 'OK, Gary,'

Identify: 'immediately after the vehicle entrance with the red letterbox'

Direct: 'I would like you to pull over and then carry out a three-point turn.'

## Specific instructions

'Hold back' or 'Hang back': This instruction should be given whenever you require the trainee to wait before carrying out an action or a manoeuvre. It might apply, for example, where the driver needs to wait behind a parked vehicle on a narrow suburban street, until oncoming traffic passes.

Holding or hanging back involves more than simply giving way, however. It also means slowing down to give traffic time to clear, perhaps at intersections, or increasing following distances to improve visibility or reduce the risk of a crash.

The instruction can be used to assist with improving the judgement of speed and timing, skills lacking in many learner drivers. The instruction should be introduced early in a training programme so that the trainee quickly gains an understanding of the performance required.

'Give way': A flexible instruction that transfers responsibility to the trainee requiring them to make judgement calls.

'Stop!': This command is the verbal equivalent of using a dual control brake pedal and should be avoided unless that is what is required, immediately, of the trainee. If a student is tense or nervous, the command 'Stop', incorrectly used, could result in an unplanned emergency stop and an embarrassing rear end collision.

## Crisis management

A crisis is defined as being a 'fluid, unstable and dynamic situation which can occur anytime, anywhere without any warning'. In driving instruction this is a premise that is accepted by instructors who acknowledge that, with proper planning, crises can be overcome.

Crisis management planning requires instructors to consider the 'What if?' questions. Advanced planning that removes, or reduces, any training risk, allowing it to be controlled, is a form of crisis management. This gives rise to the need to consider verbal and physical intervention while training drivers.

The three essential steps in crisis management are:

1. Identify the crisis – quickly.
2. Isolate the crisis – quickly.
3. Manage the crisis – quickly.

## Intervention and safety

Trainee drivers cannot always recognise potentially dangerous traffic situations in time to use the hazard action plan, something they should have learned to do very early in their training. Instructors must also read the road and anticipate incorrect, or inappropriate, responses by trainees to hazards, and be prepared to intervene either

verbally or physically. What you do in these situations, to minimise the potential risk to both the trainee and other road users, is part of crisis management planning.

The six circumstances in which you should intervene are:

1. to relieve the student from culpability in adverse traffic conditions
2. to relieve the student from undue trauma in adverse traffic conditions
3. to preclude the risk of injury to people
4. to preclude the risk of property damage
5. to prevent the student breaking the law
6. to prevent mechanical damage to the car.

Two methods of intervention are open to instructors:

1. Verbal intervention.
2. Physical intervention.

### Verbal intervention

Verbal intervention is the most common form of crisis management by driving instructors. It is useful in dealing with most traffic situations or driver errors. Commands range from cueing a trainee's memory, to a command for a specific and immediate response.

Generally, cueing is associated with early lessons but can include instructions such as:

- 'check the mirrors before changing lanes'
- 'brake harder'
- 'more gas' (or 'accelerate')
- 'find the holding point. Hold it.'

Positive commands to relieve potentially dangerous traffic situations often require the student to slow down sooner when approaching hazards. The commands require specific action but do not deprive the student of exercising some judgement.

Instructions include, for example:

- 'Hold back.'
- 'Give way.'
- 'Stop!' Mentioned earlier, this command is used in situations that might be getting out of control or where previous instructions have been ignored or failed to achieve any response. The trainee must, however, understand the expected response to this instruction.

### Physical intervention

Physical intervention should be restricted to situations where verbal intervention has failed, or where no time exists to issue verbal instructions. Methods of physical intervention are dependent upon the type of vehicle being used. In a dual control car with a manual transmission, for example, you can use the dual control footbrake and clutch from the passenger's seat. In a normal vehicle, instructor control cannot be achieved to the same degree and is limited to interventions such as:

- sounding the horn
- reaching over and holding the steering wheel
- switching off the engine

- selecting a missed gear
- releasing a partially applied handbrake
- applying the handbrake
- preventing an inappropriate gear change by covering the gear lever.

These can, of course, also be applied by the instructor in a dual control vehicle.

You must consider the intervention best suited to specific errors. For driving instructors, crisis management planning could be called 'Leaving yourself an out.' Some situations, for example, might require both steering and braking interventions to resist any trainee tendency to swing the wheel or remain 'frozen' on the accelerator.

Using the dual control footbrake:

1. Keep the foot near the brake without alerting trainees.
2. Cover the brake if traffic conditions require it.
3. Avoid 'playing' with the brake. It distracts trainees.
4. If a trainee 'freezes' on the accelerator, it is not advisable, unless absolutely necessary, to use the dual clutch to compliment the brake. The consequence of uncontrolled engine speed could be a badly damaged engine.
5. If trainees sense sudden movement towards the brake, or feel a pressure change on their pedal, they may instinctively try to brake harder. This can be potentially dangerous for following traffic or may lock-up the wheels.
6. Check the dual control mirror before braking.
7. After parking at the side of the road, explain to the trainee why the brake was used.
8. Reducing vehicle speed with the dual control brake may give the trainee more time to turn the steering wheel in situations where it might otherwise be difficult.

Taking control of the steering wheel:

1. Grasping the wheel from the passenger's seat may be the only safe or practical method of intervention.
2. The possibility of this occurring can be minimised by selecting routes that are appropriate for the trainee's ability.
3. For any major steering correction, take a high position on the wheel with the right hand to get more leverage for left turning. For turning right, take a low hand position to push the wheel up.
4. When turning the wheel avoid touching the trainee.
5. Remember that even quite frail trainees who are 'frozen' at the wheel, can become immensely strong, resisting any attempts to turn it.
6. Using the steering wheel to make corrections to course and position is a more practical, safer alternative to using the dual control brake when the trainee is steering towards the kerb, or is too close to oncoming traffic, parked cars, cyclists, or pedestrians.
7. Trainees may resent physical intervention with the steering wheel, especially if they do not immediately understand the reason. Be sure to explain why physical intervention was necessary, even if the reason is, at least to you, obvious.

Using the dual control clutch

Physical intervention using the dual clutch is generally not necessary. Avoid it except in exceptional circumstances.

## Dual control mirrors

Dual control mirrors are fitted to the windscreen. One is used to give you a view through the rear window of the car, to monitor following traffic, and a second is used to monitor the trainee's eye movement as they apply visual search patterns. This second mirror should be placed unobtrusively but the reasons for using the mirrors need to be explained to the trainee before training commences.

## Driving school crashes

If trainees are learning under professional supervision, the learner driver is much less likely to be involved in a crash than even a more experienced, but untrained, driver.

Driving instructors provide a safe learning environment for students by:

- planning routes based on student ability
- forward planning and continuously monitoring the driving conditions
- anticipating the trainee's actions
- giving clear instructions, in plenty of time, for the trainee to respond appropriately.

Most crashes involving driving school cars are rear-end collisions involving the car behind.

The two key reasons for this are:

- many learners are reluctant to slow down, give way or stop because they must then move off again. This reluctance to slow down or stop when facing a driving hazard can quickly turn into an emergency stop. If this situation occurs, trainees tend to react in one of two ways. They either freeze at the controls or they over-react by slamming on the brakes. Regardless of who stops the car, the trainee or the instructor, the result is likely to be the same if the driver behind is tailgating or is distracted
  - stalling when moving off into a roundabout or intersection is the other main cause of rear end collisions. For example, when the trainee begins to move off, the driver behind looks right, planning to move into the space the trainee should have vacated. Unaware that the trainee has stalled (or the instructor braked because of approaching traffic), the following driver, who is not looking ahead, drives into the rear of the stalled vehicle. This situation, once again, highlights the importance of route selection based upon student ability.

Other potential problems that you should prepare for in your crisis planning are:

- when approaching traffic lights, some trainees tend to do an emergency stop if a green light changes to amber, even though they have already crossed the stop line
- right turns at traffic lights can be difficult for learner drivers. In busy traffic conditions they are often unable to apply adequate search techniques while applying manipulative skills and legal obligations
- a trainee driver negotiating an intersection hindered by view blockers or with limited visibility requires good perceptual skills, something that only develops with time and experience
- learner driver's hazard response times, and their ability to estimate the speed of other vehicles, are not as well developed as those of a more experienced driver. This makes gap selection decisions critical, particularly when joining heavy traffic flows, and makes turning onto busy roads a potentially dangerous manoeuvre
- you must be ready to compensate for any sudden and excessive driver responses during low speed manoeuvres, where even a slight error by the trainee might prove expensive
- when moving off at intersections, overtaking or changing lanes, you must monitor vehicle blind spots, cueing the trainee if necessary, before any manoeuvres occur.

## Evaluating competency

Competency must be demonstrated at the completion of each stage of learning. To achieve competency, each skill should be 'over-learned'.

Using progressive learning stages increases motivation to learn by sustaining a sense of commitment and accomplishment. Progress based on competency at each stage of learning helps develop a sense of achievement and confidence as each objective is met.

No matter how carefully prepared and presented, the success of training can be judged only by how much of the intended knowledge and skill the trainee takes away from the driving lessons. The complete experience involves the car, the classroom and the personality and teaching methods of the instructor. The previous knowledge and skills of the trainee provide the foundation on which to build success.

In assessing the success of training, two types of evaluations are necessary:

- Formal: criterion-referenced assessments.
- Informal: feedback.

The formal evaluation, the criterion-referenced measurement, is easy because the criteria have already been stated in the objectives written before training began. The principles of feedback can be the more time-consuming to apply. Feedback begins from the moment you first speak to a trainee.

### Criterion-referenced assessment

Criterion-referenced assessments tell us how well individual trainees are performing in relation to specific goals or standards rather than just telling us how their performance compares to a group of trainees nationally or locally. In criterion-referenced assessments, it is possible that none, or all, of the trainees will reach a particular goal or performance standard.

The assessment process requires the right tools to determine the performance of the individual. The measurement is compared with a performance standard. The measurement is not compared against something for which no objective standard has been set.

To measure the distance it takes a person to stop an automobile from a speed of 50km/h, you would use a tape measure, not a thermometer. The assessment compares a measurement (the distance it took to stop the car), with a pre-established standard and makes a comparison. The standard is either met or it is not met. That's it.

In relation to training, criterion-referenced assessment refers to comparing a trainee's performance with the designated standard and judging whether the trainee met, did not meet, or exceeded the standard.

Driving instructors are in the business of training students to drive cars. You determine the performance standards required of your own students. The training objectives, which consist of the conditions, performance and standards statements, must be included into every lesson plan. Because criterion-referenced assessments measure whether an objective has been met, instructors whose objectives are derived from needs analyses have established criterion-referenced measures. To apply the measure, you simply ask the trainee to demonstrate the performance required by the objective, under the stated conditions, to the required standard.

As an example, if you require a trainee driver to demonstrate their ability to maintain a safe following distance when driving on the open road, then the trainee's performance must be measured in traffic on the open road. It cannot be measured while the trainee is driving on a quiet suburban street or is seated in a classroom.

### Principles of feedback

Feedback is an essential part of the process in every learner driver's experience. It is part of the learning experience.

Facilitators should focus more on individual strengths than on weaknesses. This focus is crucial to establish a positive learning climate.

Feedback to individuals, and the way it is provided, will affect the learning climate and the beneficial effects experienced by individuals. A learning experience is more successful when positive attitudes are expressed by the facilitator.

In a learning group, each person can assume responsibility for assisting others in learning. Feedback is one way that people help each other.

The 11 principles for the use of feedback are:

1. Focus feedback on behaviour rather than on personalities.
2. Focus feedback on observations.
3. Focus feedback on description rather than on judgment.
4. Focus feedback on descriptions of behaviour which are in terms of 'more' or 'less' rather than in terms of 'either/or'.
5. Focus feedback on behaviour related to a specific situation, preferably to the 'here-and-now', rather than on behaviour in the abstract, as in the 'there-and-then'.
6. Focus feedback on the sharing of ideas and information rather than on giving advice.
7. Focus feedback on exploration of alternatives rather than on answers or solutions.
8. Focus feedback on the value it may have to the receiver, not on the value of 'release' that it provides the person giving the feedback.
9. Focus feedback on the amount of information that the person receiving it can use, rather than on the amount that you might like to give.
10. Focus feedback in time and place so that personal data can be shared at appropriate times.
11. Focus feedback on what is said rather than why it is said.

## Summary of the learning process

- Begin with what the trainee knows, or can do, and build upon it.
- Structure the learning into short progressive steps.
- Promote progress with clearly defined objectives.
- Be consistent and clear with instructions and terminology. Ensure that trainees understand, and react, to instructions without hesitation.
- Keep explanations short and to the point.
- Emphasise the key points of the driving task using plain English.
- State what trainees must do in a positive manner rather than telling them what not to do.
- Explain the purpose of a demonstration before carrying it out.
- Demonstrate a driving task, explain the components of it and have the trainee practice the task.
- Restrict demonstration explanations to key points. Too many instructions at once confuse. Keep it simple.
- Follow a demonstration immediately with practice. Some trainees will benefit from longer periods of practice but ensure lessons are of a manageable duration.
- Ensure learning by 'doing' but let trainees learn at their own pace.
- Leave no doubt about what is expected of the trainee.
- Ensure that learning conditions are within the trainee's ability to cope, especially the route and traffic conditions.
- Ensure that initial practice is successful. Success stimulates interest and involvement.
- Motivate trainees with praise and encouragement.
- Strive for small successes for a trainee who finds the learning difficult.

- Vary instructional techniques if the early methods appear unsuccessful.
- Avoid fear of failure or of allowing trainees to make fools of themselves. It causes anxiety. Failure saps confidence and inhibits future progress.
- Reassure trainees. Encourage them.
- Avoid excessive criticism. It destroys confidence and the desire to learn.
- Provide trainees with continuous feedback on progress.
- Correct initial errors before they become bad habits.
- Criticise objectively. Describe the desired performance. Don't judge the student.
- Reassure trainees that periods of slow learning are common and quite natural. If they feel they are making no progress, an unsympathetic instructor can cause them to become completely demoralised.
- Avoid comparing one trainee with another.
- Change an activity to help sustain interest. Excessive repetition, while often important, can be boring.
- Avoid expanding on the subtleties of the driving task before the trainee has grasped the key points.
- Prepare and use lesson plans that reflect the specific needs of the trainee.

## The first driving lesson

The first driving lesson is different to subsequent training sessions, but is critically important in relation to the development of a rapport between the trainee and the instructor. Before conducting this lesson you must determine some basic information.

You must not rely solely on trainee information about previous driving experience. Some trainees will say they are advanced drivers when, in fact, they are not, and others will claim to have only a basic knowledge but will prove to be quite competent during an assessment drive. In both situations, previous experience is apparent but an assessment will be required to find the true levels of competence.

If trainees have no previous driving experience then, obviously, an assessment is out of the question and training will start with the most basic of lessons.

### Initial introductions

First impressions are crucial for the future success of a training programme. Trainees must quickly develop confidence in their instructor and to achieve this, you must be seen as a committed, knowledgeable and confident professional. You should be able to remember the trainee's name without reference to the appointment diary when you introduce yourself and you must display an interested and approachable attitude. Trainees should be encouraged to speak about any relevant concerns, regardless of how trivial they may seem.

The car, whether it belongs to a driving school, a client company or the individual trainee, should be legally roadworthy and have sufficient fuel for the lesson. You must be satisfied that the following standards have been met:

- The driver is carrying a current driver licence.
- The driver is not under the influence of any medication, drugs or alcohol.
- The driver is not suffering from any adverse affects resulting from illness or emotional issues.
- The vehicle is currently licensed.
- Vehicle warrant of fitness and registration are current and correctly displayed.
- Road user charges licence (if applicable) is valid and displayed.

- The vehicle is in sound mechanical condition and has been checked for fuel, oil, water, clean glass, electrics, tyres etc.
- Where required, L plates are displayed.

You must also brief the trainee on the content and objectives of this first lesson and explain how it will be conducted.

Drive student to a suitable route

The route or venue must reflect the needs of the trainee. It must suit the trainee's level of competence and match the lesson to be taught. It must also allow progression for those who demonstrate the ability to handle more complex driving situations.

Establish previous experience and other details

Depending on the lesson, driving to a suitable location to begin the first lesson can be used as a time to gather information. Avoid long silences as they only add to the nervousness of the trainee. A friendly, informal chat along the way serves three purposes:

- It breaks the ice between the instructor and trainee.
- Talking helps calm the trainee and keeps their mind off the upcoming lesson.
- A chat often provides information that can assist trainees in achieving their goals.

If trainees are reluctant or a little shy, initially, to talk about themselves, respect this. Other opportunities will arise. Some trainees will try and mask their nervousness by talking all the time. Whatever happens, your responses should be professional but sympathetic.

Questions should be posed to gather information. For example:

- Is the trainee still at school or university?
- What kind of work does he/she do?
- What interests and hobbies does he/she have?
- Has he/she any physical disabilities or limitations?
- Does he/she need to drive in their work?
- Previous driving experience with any vehicle, motorcycle, bicycle, etc.
- Has he/she any fears about learning to drive?

A word of warning is appropriate in relation to trainees who are full licence holders. An element of tact and diplomacy will be required. They must not be treated as learners but rather as equals. Don't expect habits that have developed over years of driving to suddenly change. If the skill doesn't measure up to your ideal, you should ask yourself whether an issue actually exists that requires remedial training. Steering technique, transmission use and park brake use are all examples of skills that might be best left alone if there are no safety or control issues attached to them. Alternatively, if some action is required, phrase the recommendations for change in a manner that reflects valid reasons for the changes being made. These might include monetary savings that can be made by the driver, or explanations of changes in technology that make the current responses redundant. You and your trainee need to work together on the problem rather than have one feeling that the other is 'nit picking'.

Explanation of the controls

On arrival at the venue or start of the route, you must, where necessary, explain the vehicle controls. How detailed this explanation is, and how long it takes, will depend upon the trainee's previous experience and ability. On this first outing, explain only the main controls and those that might be needed during the lesson. Ancillary controls/instruments are often better left until a later lesson.

Remember to ask questions at regular intervals to confirm what the trainee may already know and to confirm assimilation of the information presented.

The teaching points for this first lesson might include:

- Preliminaries: Safety considerations, introduction to the vehicle, vehicle document checks, entry checks (park brake, gear lever position etc), seat and mirror adjustments, location, purpose and operation of relevant controls, start/stop the engine, information on vehicle speed and performance.
- Familiarity with safety controls: Rear-view mirrors, indicators, lights, wipers etc.
- Familiarity with main controls: Steering, gear lever, park brake, foot controls, accelerator, footbrake, clutch.

Once the trainee has demonstrated familiarity with all of these, the lesson proper, following a lesson plan, can begin.

## Subsequent lessons

Before the lesson

Prepare the lesson by establishing the training objectives and deciding on the skills to be taught.

- How can the objectives best be achieved?
- What teaching methods should be used?
- What specific traffic situations are required?
- Is the selected route appropriate for both the lesson objectives and the ability of the student?
- What learning aids might assist with explanations?
- Does the student need notes to study between lessons?

Always prepare and use a lesson plan, even if this is only used for occasional reference and to provide evidence of instruction and outcomes. The lesson plan should include:

- lesson objectives
- revision
- teaching points
- method of evaluating the performance of the objectives.

Consider the availability of alternative routes and try and anticipate any problems that might arise from the trainee or the vehicle and any likely external disruptions.

Explain to the trainee the sequence of the lesson, the objectives of the lesson and the expected outcomes.

Make sure vehicle and driver checks are completed prior to the commencement of each lesson.

During the lesson

Conduct revision of the previous lesson(s) and make sure competency is demonstrated before commencing the new lesson.

The training should follow the sequence of the lesson plan and the instructor must:

- progressively address the individual's training needs
- promote driver self awareness
- promote driving safety
- promote awareness of driving rules
- positively reinforce the learning with comments and expert demonstrations

- transfer driving responsibility progressively by conducting the lesson in a logical sequence and confirming instruction in stages
- allow the levels of complexity to develop progressively.

All teaching points must be explained and demonstrated by you and then practiced by the trainee.

The trainee's exposure to risk must be minimised by encouraging risk reduction techniques such as the hazard action plan and the system of vehicle control.

Issue all instructions to the trainee in an appropriate manner. Instructions must be:

- logical
- timely
- accurate
- without verbal distractions.

Use training aids, where appropriate, that support the lesson objectives and content.

Conduct the assessment of the performance objectives at the completion of the lesson. Identify any deficiencies, the causes of them and likely consequences. Record these on the lesson plan.

After the lesson

- Debrief the driver in relation to the lesson achievements. Involve the trainee in this process by eliciting their feelings and reactions to the days learning event.
- Discuss any discrepancies arising from the assessment of the lesson objectives. Include in the discussion any recommended solutions to rectify these.
- Provide positive reinforcement by recapping the main points of the lesson and complimenting them on the things they did well.
- Inform the trainee of the place, time and content of the next lesson.
- You and the trainee should also agree on the work to be accomplished before and during the next lesson, that is 'where to from here?' This agreement allows the trainee to have a clear understanding of the instructor's expectations in preparing for the next lesson.
- Complete trainee documentation including lesson plan notes and the training plan and transfer information onto the individual's training file.

## Drivers approaching driving test standard

Because of the nature of a driving test, instructions to trainees approaching driving test standard should be quite neutral. While they must also be clear and precise, instructors must guard against giving trainees verbal cues so they have to make all the decisions themselves. You must be familiar with the testing process and should be able to explain what the trainee should expect on the day. It must be reiterated here that trainees should not be exposed solely to the test circuit in preparation for the test. This does not constitute the provision of professional driver training and limits the trainee's exposure to the driving conditions and the wide range of potential hazards that they will be exposed to on a daily basis.

The ideal indicator for a driver's suitability to pass the driving test is the successful completion of the driving assessment presented in this manual.

The way in which instructions are issued when you pre-test drivers needs to be revisited here.

Telling advanced trainees, for example, to 'Turn left at the stop sign', provides information that they should discover for themselves. Some information can be justified on a particularly complex part of a route, however. In some areas, distinguishing which lane will be required might be difficult without local knowledge of the area. In these circumstances the student may need to be told which lane to select.

Remember these points relating to verbal instructions:

1. Late instructions can lead to:
  - rash, rushed decisions
  - poor vehicle control
  - poor observation skills
  - erratic steering
  - lack of confidence.
2. Avoid the word 'Stop!' except in an emergency.
3. Avoid beginning an instruction with words like 'Turn' or 'Pull up', or any verb referring to a manoeuvre. Using the phrase 'We are going to...' alerts the driver to the fact that an instruction will follow.
4. Avoid using the word 'right' for anything other than a directional change. For example: 'Right! Turn left at the next intersection', can cause serious confusion, as can, 'That's right!' meaning, 'That's correct!'

### Driving test standards

The following NZTA publications are available to driving instructors and provide an outline of the test format and driving competencies required to successfully pass the class 1 restricted and full licence driving tests:

- Driver training syllabus: learner stage* (preparing for the restricted licence test)
- Driver training syllabus: restricted stage* (preparing for the full licence test).

Copies can be ordered at: [www.nzta.govt.nz/resources/order/](http://www.nzta.govt.nz/resources/order/).

## Section 5: Hazard identification and risk reduction

Driving is an activity that involves three distinct skill sets applied to a foundation of knowledge. These skill sets are:

- Hazard identification (including anticipation and perception).
- Decision-making.
- Practical driving ability.

Building a foundation of knowledge must start before a trainee driver is exposed to the rigours of a busy driving environment and will continue to develop with experience and exposure to increasingly complex driving situations and conditions.

A competent driver is one who not only understands the rules of the road (part of the knowledge foundation) but also understands how those rules, when applied, will affect other road users around them.

Experiences, both good and bad, and the ability to concentrate on the driving task and not be distracted, will further develop that knowledge and reduce the likelihood of a driver being involved in a crash.

The terms 'perception' and 'anticipation' are often used in the context of safe driving and warrant some explanation.

### Perception

Perception is the ability to identify potential hazards based on the sensory information presented to the driver and is influenced by driving experience, training and lessons learned. What one driver perceives as a potential hazard might not be viewed in the same way by another, simply because one driver's exposure to a potentially hazardous situation has not been experienced by the other.

Selective perception, on the other hand, is an unconscious filtration process that reduces the huge range of sensory stimuli to which a driver is exposed to that small portion that they believe is of relevance. In simple terms, the driver chooses to see only what they want, or think they need, to see, screening out information which they do not understand or do not wish to recognise. The problem is most apparent, but not exclusively, with young drivers who have insufficient driving experience to prioritize, or even acknowledge, hazards or appreciate the risks arising from them.

### Anticipation

Anticipation is the ability to predict situations that may arise as a result of a range of clues presented to the driver from the driving environment. Once again, experience will play a key role in a driver's ability to anticipate driving situations but driving instructors have to encourage the development of the skill from a very early stage in training.

To understand the importance of perception and anticipation the new driver must first understand what driving hazards are and where they come from. They must also accept that driving hazards commence as soon as the vehicle starts to move, and sometimes even before it moves.

### Hazard recognition

A hazard is any situation that contains an element of actual or potential risk, which must be negotiated by the driver. In other words, if the driver fails to react to a potential hazard, an unexpected and unwanted event, like a crash may occur.

An actual hazard is one that poses an immediate threat to a driver in its current form. Examples of this might be a car failing to give way at an intersection, a child running onto the road or black ice in a corner.

A potential hazard is one that will only become a danger to the driver if something else occurs. Examples might be a car travelling at high speed towards an intersection, a child playing with a ball on the footpath or a road in shadow on a very cold, frosty winter's day.

In other words, actual hazards often evolve as a result of the driver failing to identify and react to the potential hazards first. This is where driver reactions, developed over time and, once again, with experience, come to the fore. More often than not there will be clues available to the driver allowing them to anticipate hazards.

'Driver risk tolerance' is the level of risk an individual is prepared to accept while driving and may differ considerably between individuals. It relates to a person's perception of the level of risk they are exposed to and their responses to driving hazards. An over-confident driver who believes they are capable of driving over the speed limit, irrespective of the driving conditions, because they haven't had a crash, will have a high risk tolerance. Drivers with low risk tolerance are those who will, at all times, drive to the conditions, often below the posted speed limits, and observe all the traffic rules. Inexperience, often exacerbated by peer pressure and unrealistic expectations, often results in high risk tolerance and requires driving instructors to apply sound teaching techniques, backed up with high personal standards and quality instruction, to modify trainee driver thought processes.

## The six driving conditions

The first point in hazard detection that has to be acknowledged is that the driving hazards arise from what are known as the 'six driving conditions'.

These conditions are continually changing and this is why driver attention, without unnecessary distractions, is so critical to safe driving.

**Weather:** These hazards relate to the influence that the weather has on driving either directly, as with wind and rain, or indirectly as with temperatures and visibility.

**Road:** The road conditions present the biggest number of immediate potential hazards simply because the driver is continually reacting to road conditions such as corners, hills, signs and controls and surface conditions.

**Light:** This relates to a range of light factors that can potentially cause problems for the driver and for other road users. Light related hazards can arise as a result of natural ambient light levels or from other road or traffic conditions and include sun strike, head light glare, night driving and reflective surfaces.

**Traffic:** These hazards relate to other road users and the influence of their actions, or inactions, on our driving. They include traffic volume and speed, type of traffic, behaviour and location.

**Driver:** This is you, the driver of the vehicle and factors that will influence your ability to operate a vehicle in a safe and efficient manner. It includes things like the effects of alcohol and drugs, illness, attitude and ability and fatigue.

**Vehicle:** This relates to the vehicle you drive and takes into account all those factors that will influence the way in which it handles and how it interacts with other road users. These include weight, power, dimensions, colour, load, speed and vehicle condition.

Drivers have no influence over the presence of the first four of these conditions but their personal decisions have a direct bearing on the last two, the driver and the vehicle, and this is reflected in the crash statistics.

Every turn of the steering wheel, every gear change, brake application and signal is a reaction of the driver to a potential hazard.

## The seven driving manoeuvres

For driving instructors, the importance of the seven driving manoeuvres cannot be overstated. With learner drivers there is a need to have a foundation for teaching the practical driving skills and for developing a knowledge base. Driving is, in effect, continuous movement in and between these manoeuvres, each of which reflects, and creates, a different interaction between the trainee and other road users and a change, often subtle, in the driving conditions. These manoeuvres play a less important role in the thought process once a driver has

developed, and can apply consistently, the required skills and knowledge, but for a trainee the seven manoeuvres are stepping stones to those competencies.

While the seven manoeuvres have been covered previously in section 3, it is appropriate that they be repeated here along with simple risk reduction techniques.

### Moving into the traffic (moving in)

Moving into the traffic means joining the traffic flow. This may occur when changing from one lane to another and merging with traffic in the other lane, when entering from a side-road, vehicle entrance, when moving off from the side of the road and when using a motorway on-ramp.

'Moving in' traffic requires the driver to signal, apply appropriate scanning techniques (to the sides, behind, over the shoulder check, 12-second search ahead), apply correct gap selections (giving way if necessary), accelerate quickly and smoothly to appropriate speed and maintain correct road position.

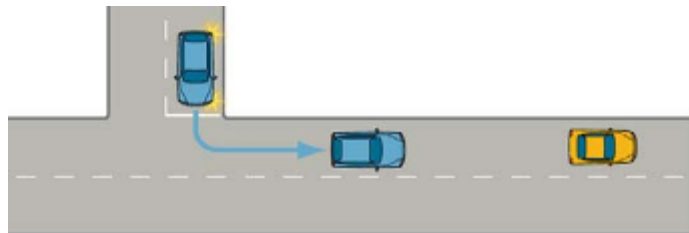

### Moving on the road (moving on)

Moving on the road means keeping the vehicle safely in the right place on the road without the presence of other vehicles travelling in close proximity in the same direction. Driver actions and responses will not therefore be influenced by other road users, except perhaps by oncoming traffic. Moving on includes changing lanes (when not merging with other traffic), cornering, driving in a straight line and handling emergencies.



'Moving on' requires drivers to apply speeds appropriate to the driving conditions, maintain correct lane position, use correct steering techniques, apply appropriate scanning techniques (to sides, rear-vision mirror, 12-second search ahead) and where appropriate apply effective cornering technique and line

### Moving with the traffic flow (moving with)

Moving with the traffic flow relates to driving the vehicle in close proximity to other road users. This will include vehicles behind, vehicles ahead and vehicles alongside. Traffic includes all road users including cyclists and pedestrians.

'Moving with' other traffic requires the driver to maintain appropriate speed for the conditions, apply correct following distances, apply correct steering techniques, maintain correct lane position, use correct lanes, and apply appropriate scanning techniques (to the sides, behind, 12-second search ahead).

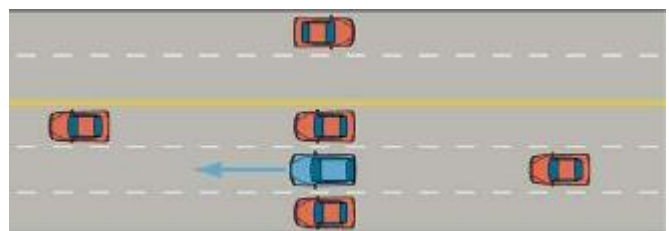

### Moving through traffic (moving through)

Moving through traffic refers to moving the vehicle through situations and potential hazards where other traffic may cross your path. It includes all intersections (including roundabouts), roadworks, pedestrian crossings, railway crossings and any situations where officers may be directing traffic.

'Moving through' requires the driver, throughout the manoeuvre, to apply appropriate scanning techniques, correct steering techniques, signal where appropriate, maintain correct road position, use correct lanes, apply appropriate speed, comply with controls (give way, stop, traffic lights), and select appropriate gaps, giving way where required.

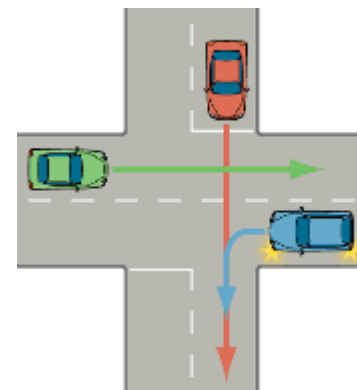

### Moving past other traffic (moving past)

Moving past other traffic relates to vehicles travelling in the same direction at different speeds going past each other safely. It includes moving past, or being passed by other vehicles, and also includes issues relating to passing parked or stationary vehicles and to pedestrians on or near the road.

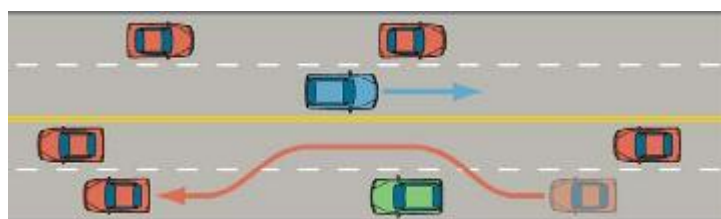

'Moving past' requires drivers apply appropriate scanning techniques (to the sides, behind, over the shoulder check, 12-second search ahead), signal, maintain correct following distances, apply appropriate speeds and maintain correct lane position.

### Moving back in traffic (moving back)

Moving back in traffic means driving the vehicle back along the direction from which it has just come. It includes reversing into parking spaces or vehicle entrances and making u-turns or three-point turns.

'Moving back', depending on the manoeuvre being undertaken, may require the driver to apply appropriate scanning techniques (to the sides, behind, over the shoulder check, 12-second search ahead), signal, select an appropriate gap giving way where required and apply correct lane position.

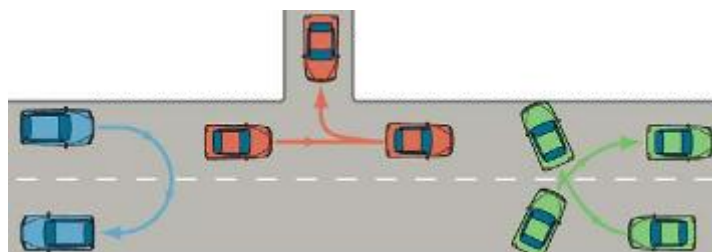

### Moving out of the traffic (moving out)

Moving out of the traffic means leaving the traffic flow. It includes the use of motorway off-ramps, pulling into parking spaces and turning into driveways or side streets by making left or right turns.

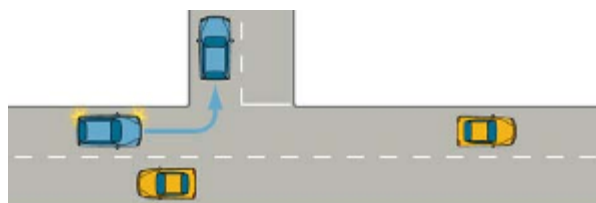

'Moving out' of traffic flow will require the driver to signal, apply appropriate scanning techniques (to the sides, behind, over the shoulder check, 12-second search ahead), adopt correct lane positions, give way where necessary and adjust speed to suit the conditions.

By familiarising trainees with the seven driving manoeuvres, they are exposed to all the legal obligations and safe driving practices that will hold them in good stead once habitual risk reduction skills have been developed. Each of the manoeuvres can be used as a lesson in its own right, if that will benefit the trainee, and they must all be included into any driver assessments as a measure of overall competence.

## The six crash positions

Once a trainee understands the influences of the seven driving manoeuvres on overall driving performance they should also appreciate that failure to apply the basic risk reduction techniques can, and often will, lead to vehicle crashes.

While single vehicle road crashes feature prominently in crash statistics, they generally occur as a result of driver error or behaviour. Of the seven manoeuvres, single crashes will most often occur when 'moving on' and the root cause will often reflect excessive speed, alcohol, fatigue, inexperience or peer pressure. Frequently, it is combinations of several of these factors.

In all other crash situations, two or more vehicles will be involved and, once again, with effective training, risk reduction techniques can be applied to minimise the likelihood of a crash occurring. The crash positions can be related to the driving manoeuvres and can, therefore, be linked in the same training programme.

In the scenarios below, you are the driver of the blue car.

Vehicle ahead: You crash into the vehicle in front of you.

### Risk reduction

- Apply the 2 and 4-second rules.
- Search ahead and behind to identify potential hazards.
- Pay attention to driving conditions.
- Be aware of sun-strike and keep windscreens clean.
- If you can't overtake, hang back.
- Adjust speed to suit traffic flow.
- Avoid distractions.

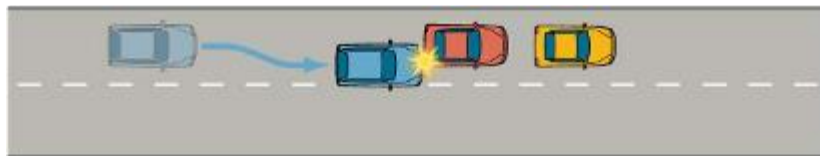

Vehicle behind: You are hit by the car following you.

### Risk reduction

- Consistently monitor rear-view mirrors.
- Increase your own following distance if another vehicle is tail-gating you.
- Be prepared to indicate left, pull over and let following traffic past.
- Don't increase speed in passing lanes.
- Increase the distance between vehicles when stopped and keep the foot on the brake pedal.

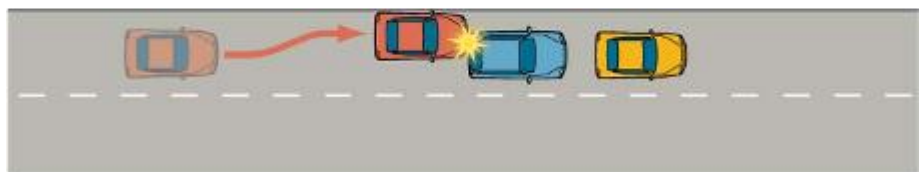

Oncoming: You crash head-on with the vehicle coming towards you.

### Risk reduction

- Stay alert and rest often.
- Don't cut corners and stay entirely within your own lane.



- Make sure you have at least 100m clear visibility throughout any overtaking manoeuvre.
- Regularly service your vehicle brakes, suspension and tyres.
- Avoid distractions.
- Speed for conditions.
- Courtesy and patience.

From the side: You are hit by a vehicle approaching from your right or left.

#### Risk reduction

- Always signal your intentions.
- Maintain correct lane position.
- Apply the give way rule correctly and be prepared to stop.
- Observe all signs and controls including stop signs.
- Don't run late amber or red lights.
- Search into all intersections even if you have right-of-way.
- Drive at a speed whereby you can stop safely.
- Avoid distractions.
- Courtesy.
- Gap selection.

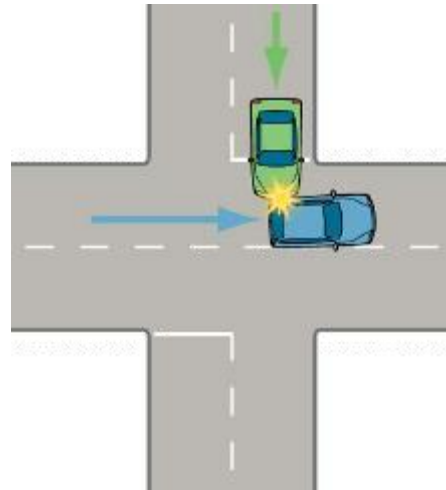

Passing: You hit a vehicle you are passing.

#### Risk reduction

- Check ahead and behind before pulling out to overtake.
- Signal your intentions.
- Flash your lights or sound your horn if you think the other driver is not aware of your intentions.

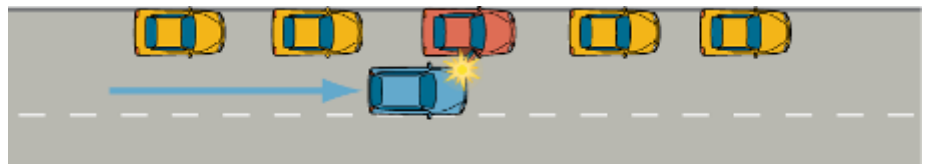

- Make sure you have at least 100m clear visibility throughout the whole manoeuvre.
- Pull back in when you can see both headlights of the vehicle you have overtaken in your rear-view mirror.
- Don't run too close to the vehicle you are overtaking.
- Look for doors opening on parked cars.
- Avoid distractions.

Being passed: You are hit by a vehicle passing you.

#### Risk reduction

- Frequently scan your mirrors for following traffic.
- Maintain your lane position.
  - Reduce speed, if necessary, to assist overtaking vehicles.
- Do not speed up.
- Be prepared to pull over and stop.
- Check behind before opening doors when parked.

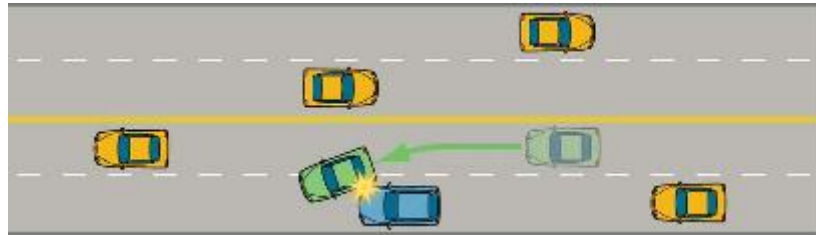

It has been said, quite correctly, that every crash could be avoided if one driver, and not necessarily the one at fault, had done something differently. To achieve this, drivers have to understand their legal obligations, possess a reasonable standard of practical driving ability, understand the effects of their actions, or inactions, on themselves and on other road users and apply a courteous driving style. With a professional standard of training these things can all be achieved reasonably easily.

Remember, risk reduction is dependent upon the driver consistently applying simple skills and knowledge in all manoeuvres irrespective of the driving conditions. For example, whether another vehicle is present or not, drivers must signal any intention to turn, obey traffic controls and observe speed limits. Failure to achieve this leads to 'selective' responses to driving manoeuvres and increases the risk of crashes.

## Observation techniques

The key to effective hazard identification, and a skill set that must be encouraged, from day one, are the observation techniques.

The observation techniques consist of five steps a driver must quickly develop to minimise risk both to themselves and to other road users.

1. Aim high in steering.
2. Get the big picture.
3. Keep the eyes moving.
4. Leave yourself an 'out'.
5. Make sure other road users see you.

Safe, effective driving is achieved when drivers correctly assess the ever changing driving environment in front of, to both sides and to the rear of their vehicles. They should be making driving decisions methodically and without hesitation. Their decisions should be based on the principle that every crash can be avoided if one person does something to mitigate the risk.

Good drivers understand that their decisions will be based on:

- what they can see
- anticipation of what they can't see
- circumstances which may reasonably be expected to develop.

New Zealand has one of the most challenging driving environments in the developed world in relation to weather, traffic and road conditions. With more hills and corners per 100 kilometres than most comparable

countries, busy traffic conditions and changeable weather patterns there is a need for young drivers to develop the observation skills and develop risk management strategies as quickly as possible.

## Aim high

'Aiming high' means looking well ahead along the intended path of the vehicle. The driver should be looking at where they want the car to go. Aiming high has the driver scanning ahead at least 12 seconds. At 100km/h and with the vehicle velocity at around 27 metres per second, this means on the open highway, or on a motorway, the driver will be scanning for hazards more than 300 metres ahead. That's about the length of three football fields. Often, because of corners, hills or view-blockers, this is as far as the driver can see in any case. Around town, 12 seconds is about two city or residential blocks. This means the driver is not only checking the next intersection but also the one beyond it. A hazard identified 12 seconds away gives the driver 12 seconds to react.

Learner drivers tend to look at the road immediately in front of the vehicle but aiming high in steering improves with confidence and experience.

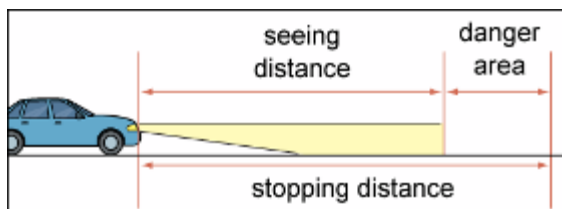

At night, or in particularly bad weather conditions, the ability to scan ahead 12 seconds will be limited by the distance that is illuminated in the headlight beam or is visible in the prevailing conditions. This means the driver, to achieve 12 seconds, will have to slow down. If something occurs within that 12-second search pattern, the driver must be

able to stop the vehicle safely. This lack of perspective causes some drivers (particularly beginners) undue

concern and leads them to make errors in judgement.



Other driving situations that might require a reduction in speed to achieve the 12-second rule include when following large heavy vehicles, when driving in busy city or urban conditions and when negotiating corners or hills.

Symptoms of low aim steering:

- Speed and steering both erratic.
- Failure to notice hazards in time to avoid them safely.
- Looking down at the front of the car.
- Car not centred in the lane.
- Using the centre of the bonnet or the boot of the car ahead, as a steering guide.
- Steering too far to the right to avoid an object to the left.
- Swinging wide during turns.
- Late reactions to corner advisory signs
- Failing to reduce speed when visibility is poor.
- Looking at the road directly in front of the car or down the centre line.

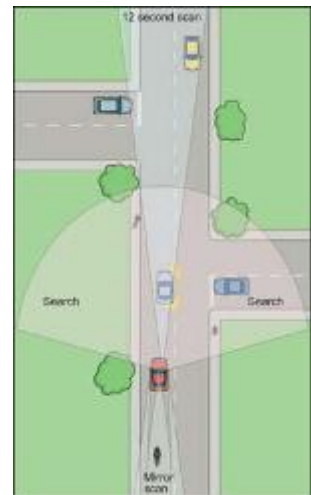

- Following too close.

## Get the big picture

This involves visual scanning, using the eyes and the brain, identifying and monitoring all the potential hazards present in the existing driving environment, not only in front of the vehicle but to both sides and to the rear.

Besides scanning 12 seconds ahead the driver should also be searching the scene between the vehicle and the most distant scanning point. As well as identifying potential hazards and points of conflict, this search will identify any changes in the speed, position and direction of other vehicles.

Getting the big picture also relates to the correct placement of the vehicle on the road. Identifying the potential hazards should influence where the driver chooses to place his vehicle in relation to other traffic. Getting this right allows the driver to have a degree of control over the actions of other drivers. On multiple lane roads, for example, a driver should use the left hand lane so that faster traffic moves past on the right hand side, not on the left where more blind spots exist and where other driver frustration can lead to problems.

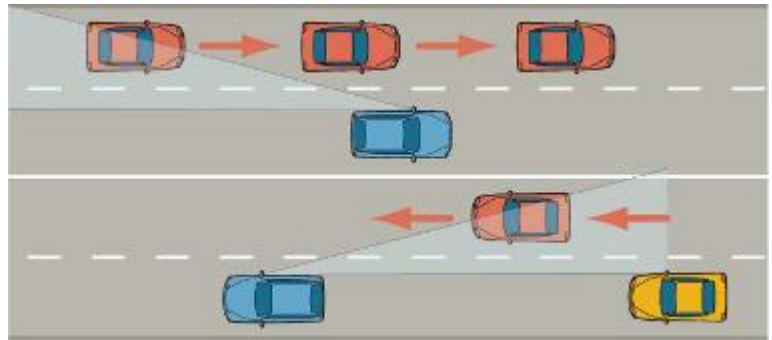

When following other traffic, applying the correct following distances is another way of reducing risk for everyone. Following distances provide a 'space cushion' ahead of and behind a vehicle which gives the driver ample time to react and brake safely without hitting, or being hit, by other vehicles.

### 2-second rule

The 2-second rule is used by light vehicle drivers in normal driving situations at any speed. The driver observes the rear of the vehicle ahead as it passes a road marker or other prominent road feature, eg power pole, tree, driveway and begins counting, 'one thousand and one, one thousand and two.' If the driver finishes counting before reaching the same point, then a safe following distance has been established.

If the driver finishes counting after reaching the same point then the following distance is too close. Slow down until a safe following distance is achieved. The 2-second rule is accurate at any speed and provides sufficient space to stop suddenly if an emergency should arise.

The faster the vehicles are travelling the greater the actual following distance will be. The slower they are travelling, the closer they will be.

In driver training many instructor instructors will apply a 3-second rule for trainees to emphasise the benefits of effective following distances and to address the potential for delayed responses resulting from trainee inexperience.

### 4-second rule

The 4-second rule is used at any speed when:

- being tail-gated
- the driver in front is tail-gating another vehicle
- towing
- driving a heavy vehicle
- in adverse weather or road conditions.

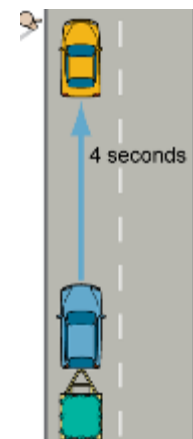
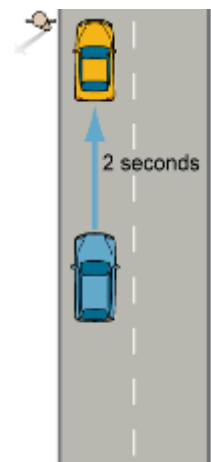

As well as making allowances for heavier vehicle weights when stopping, the 4-second rule also gives drivers some control over the vehicles that are following them. By doubling the following distance from 2 seconds to 4 seconds, any sudden braking by the vehicle ahead will allow our driver more time to react with less harsh braking. This, in turn, allows the following driver, especially if they are tail-gating, more time to brake without impacting the rear of our vehicle.

Applying the correct following distances also provides better visibility ahead, especially when following large vehicles like trucks and buses.

One factor to consider in relation to following distances is the exponential effects of kinetic energy as vehicle speed increases. Remember that a car travelling at 100km/h will require four times the distance to stop as one travelling at 50km/h.

Symptoms of not getting the 'big picture'

- Harsh, sudden stops.
- Tail-gating.
- Doesn't identify potential hazards, such as tail-gaters, soon enough.
- Responds too late to hazards.
- Frequently taken by surprise.

### Keep the eyes moving

Drivers should develop the habit of moving their eyes at least every two seconds (the eyes normally send 40 complete new pictures per second to the brain). Without this eye movement, a driver will focus on only one aspect of the driving scene while other potential hazards develop. A fixed stare is often a sign of mental distraction, target fixation or fatigue.

Target fixation occurs when a driver focuses their complete attention on just one hazard in a multiple hazard situation, to the exclusion of all others. This can occur as a result of inexperience, past experiences or selective perception and the driver may very well fail to make any steering corrections or speed reduction to avoid the hazard. Because drivers tend to aim the vehicle where they are looking, target fixation can lead to quite serious crashes. The application of effective search and scan techniques and 'aim high' steering will reduce this risk and should be addressed progressively through training. People see clearly through a small cone of central vision. When a person is standing still, their field of vision can be 180°. At 40km/h this field of vision is reduced to about 120°. At 70km/h it is further reduced to approximately 72° and once vehicle speed reaches 90km/h the field of vision has reduced by about 80% to 36°. This is only 20% of what they could see clearly while standing still.

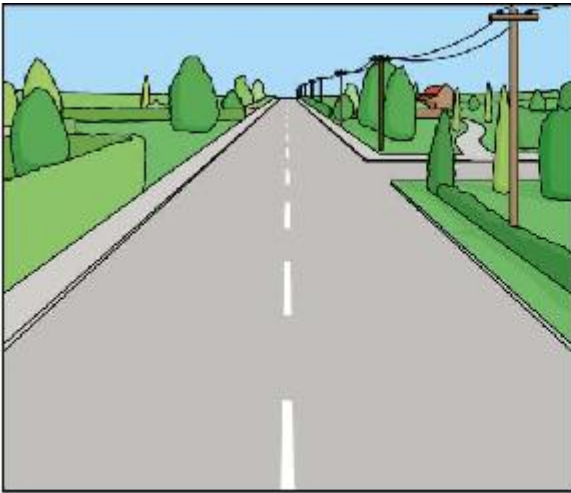

Stationary

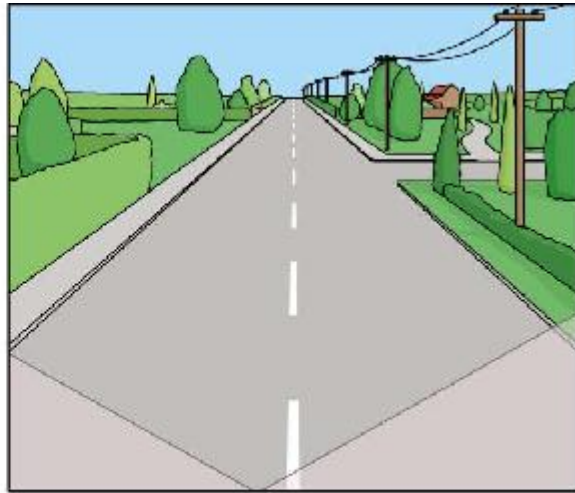

40km/h

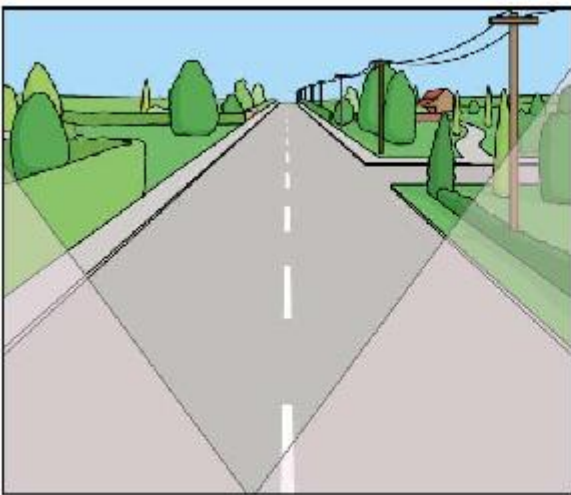

70km/h

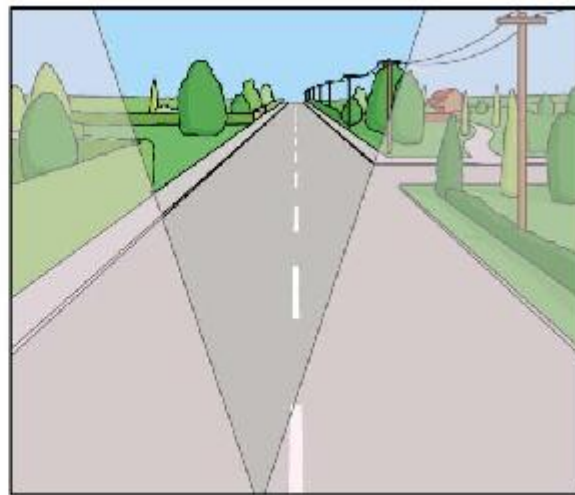

90km/h

Human vision is quite selective. Most objects outside the cone of central vision are first detected by a driver's peripheral vision (out of the corner of the eye), which alerts the central vision. When drivers use central vision alone, which is really tunnel vision, subtle and even significant changes in the wider traffic situation are often missed. Drivers should use central vision for steering, at the same time scanning the road ahead and searching to the sides for potential hazards. By developing this habit the car will track smoothly along the intended course and risk management will be achieved.

As vehicle speed increases, the ability of peripheral vision to detect hazards diminishes. At 90km/h, without keeping the eyes moving, what the driver sees is like looking down a pipe. Anything to the side becomes a blur.

Mirrors should be checked every 5-10 seconds, over shoulder checks made of blind spots before leaving the kerb, parking, merging with other traffic, turning, overtaking or changing lanes and searching the foreground out to 12 seconds applied consistently. Checking vehicle instruments also forms part of these visual checks.

When stopped at intersections, even for traffic lights, the driver should check the movement and intent of other vehicles before moving off. The first three seconds after the light changes from red to green are potentially the most dangerous.

Symptoms of failing to keep the eyes moving

- Fails to check rear vision mirrors frequently.
- Fails to check traffic movement before moving off at intersections.
- Fails to check other traffic before leaving the kerb.
- Fails to check blind spots before changing direction.
- A near miss, a surprise, when being passed by other vehicles.
- Failure to identify potential hazards outside the central cone of vision.

### Leave yourself an 'out'

'Leaving yourself an out' simply means driving in a manner whereby, should something go wrong, you can avoid a crash. Ensuring you have adequate time to take evasive action is a key factor in achieving this, identifying the potential hazards before they become 'actual' hazards.

The ability of a driver to predict the outcome of a hazard avoidance decision will be influenced by the following:

- Driver experience produces knowledge and skills. Personal experiences in a variety of hazard avoidance situations will establish a good grounding for the decision making process as will an awareness of how the vehicle will react and perform under different driving conditions. Observation techniques developed and fine tuned over time, will allow drivers to react much more effectively to potential hazards, reducing associated risk. Experience on its own, however, does not count for much if the driver has high risk tolerance or fails adopt a responsible driving style.
- Available options in response to hazards will be influenced by the driver's observation techniques, hazard recognition skills and reaction times and the driving conditions (including vehicle speed and condition). The application of basic safe driving skills such as the 12 second rule, the 2 and 4 second rules, speed for the conditions and avoiding fatigue and distractions will allow the driver to apply the hazard action plan, a key component of leaving yourself an out, effectively without any increased risk.
- Driver priorities in response to multiple hazards will be influenced by risk tolerance factors, knowledge and experience. Understanding what the vehicle will do, applying safe driving skills and effective observation techniques and concentrating on the driving task will allow the driver to prioritise responses that might be as simple as slowing down or changing direction or as drastic as driving off the road to avoid a head on collision.

The first step in achieving an 'out', however, is to observe the rules of the road. Observing correct speeds and following distances, maintaining correct lane positions, signalling and wearing seatbelts, being well rested and not drinking before driving, will reduce the potential risks not only for yourself and your family and friends, but also for other road users.

Three good driving habits that will create an 'out' are:

1. Create a space cushion around your vehicle by adopting correct lane and road positions and applying effective following distances.
2. Drive at a speed that reflects the driving conditions, which may not necessarily be at the maximum posted speed limit.
3. Apply the hazard action plan and system of vehicle control at all times and be prepared to stop if need be.

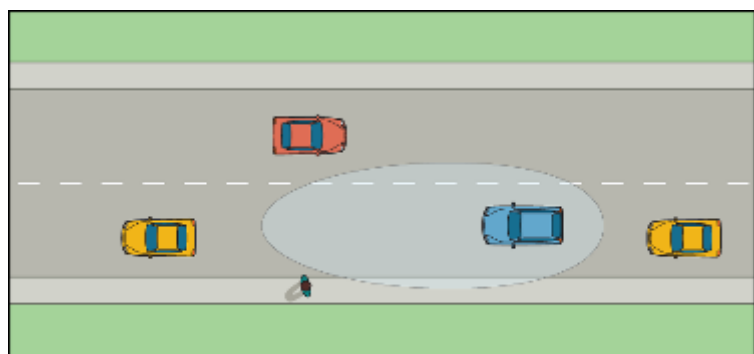

Space cushion

### Symptoms of failing to leave an 'out'

- Sudden stops or lane changes.
- Tail-gating.
- Frequently taken by surprise.
- Fast turns.
- Close calls and near misses.
- Drives too fast for conditions.
- Incorrect lane position.
- Failing to indicate.
- Poor observation skills.
- Driving under the influence of alcohol or while fatigued.
- Discourtesy.

### Make sure other road users see you

See and be seen. Take steps to ensure that not only do you know where you are going but so too does the other driver.

Communication is the key to the interaction necessary between drivers. It is achieved in a number of ways but to be of any real use it has to be transmitted effectively, received and processed correctly and perceived in the correct context.

Basic driving obligations such as headlight and indicator use and simple courtesies such as making space available, waving other vehicles on and acknowledging the courtesy of others, are all forms of driver communication. They are also examples of modelling good driving practices that other drivers, often subconsciously, 'take onboard'. Positive non-verbal communication between drivers can quickly defuse a potentially volatile situation and reduce some of the risks associated with driving.

Your vehicle, in itself, can communicate your intentions to other drivers. For example, its position on the road, the position of the front wheels when stationary and its speed can provide valuable information to other drivers who are looking for those clues.

When one driver receives information from another, whether intended or not, that information will be processed based on the perception of the receiver, and then acted upon. The identification of potential hazards is dependent upon sensory information received from the driving environment and driver communication, therefore, is part of that. There is a real risk, and it occurs all too frequently, that the messages will be misconstrued and the potential for conflict increased. Probably the best forms of communication transmitted by trainee drivers are the correct application of the driving rules in all driving situations and, with the encouragement of the instructor, a courteous, patient driving style.

A common form of driver communication is the use of vehicle lighting which serves two key purposes. Firstly, it allows you to see where you are going when it gets dark and, secondly, it allows others to see you when light levels deteriorate. Weather and light conditions, and even the colour of your vehicle, can make it difficult for other road users to see you.

The law requires drivers to turn their headlights on from 30 minutes after sunset until 30 minutes before sunrise or when visibility is less than 100 metres. In practice, this might be in the morning or afternoon on a wet, dark mid-winter's day. An overtaking manoeuvre requires 300-400 metres (12 seconds) of clear road to complete safely so it is logical that any oncoming traffic must be able to see you, and you them, much further away than 100 metres. If you can't see another vehicle 12 seconds ahead (300-400m), it's time to turn your headlights on.

Don't use park lights for driving. The fact is, you will see the car before you see the park lights.

The consistent use of indicators is another way of ensuring other road users see you and understand your intentions. The use of these should not be dependent upon the presence of other traffic. Indicator use is a good safe driving habit that must be developed early with young trainee drivers.

Symptoms of failing to see and be seen

- Irrate, unhappy pedestrians and drivers.
- Failure to use headlights correctly, courteously or when light levels deteriorate.
- Inappropriate overtaking manoeuvres.
- Failure to signal at intersections, lane changes, etc.
- 'Near misses' in low light conditions.

As we have already identified, a hazard is any situation which contains an element of actual or potential danger or risk which must be negotiated by the driver. These include:

- physical features, such as intersections, roundabouts, corners and hills
- the position or movement of other road users, including pedestrians and animals
- variations in the road and weather conditions.

## The hazard action plan

When teaching new drivers it is useful to have a systematic approach to hazards that trainees can employ from day one and which allows them to develop responses that will serve them well in all situations. This is known as the hazard action plan and with experience becomes second nature. It consists of the following four steps:

- Identify using the appropriate scanning techniques (including application of the 12-second rule), all potential hazards. Upon identifying a potential hazard the driver must then
- Predict what might happen, and then
- Decide what action to take to manage the risk, and then
- Act upon that decision.

Example: A driver is travelling down a suburban street with cars parked on the left and children playing with a ball on the footpath.



- Identify the children playing with the ball.
- Predict the ball might bounce out onto the road and a child follow it.
- Decide to play it safe, slow down, stay out to the right of the lane and be prepared for sudden movement onto the road.
- Act upon that decision.

Remember the hazard action plan: IPDA (identify, predict, decide, act).

## The system of vehicle control

While the application of the Hazard Action Plan is a mental skill, the actual response is a practical one and there is, once again, a systematic approach to teaching new drivers, and even experienced ones, how to respond. Each step of the response, known as the System of Vehicle Control, is carried out sequentially when approaching a hazard. The system develops a logical sequence for responding to hazards that learner drivers can relate to, and develop, and requires only basic skills to ensure that the vehicle is always in the correct place on the road, at the right speed and in the right gear before the hazard is negotiated.

The system can be applied to a wide range of potential hazards.

It consists of eight sequential steps. Depending on the circumstances it may be that only some of the steps relevant to the situation need to be put into action (or repeated to suit a particular situation).

1. Course: position the vehicle in the correct place on the road.
2. Mirrors: check the position of all traffic behind and alongside the vehicle.
3. Signal: indicate early, if appropriate, the intention to change direction.
4. Brake: to reduce speed.
5. Gears: change down, where necessary, and select the appropriate gear.
6. Mirrors: check, again, the position of other traffic.
7. Execute: the manoeuvre to negotiate the hazard.
8. Accelerate: away from the hazard.

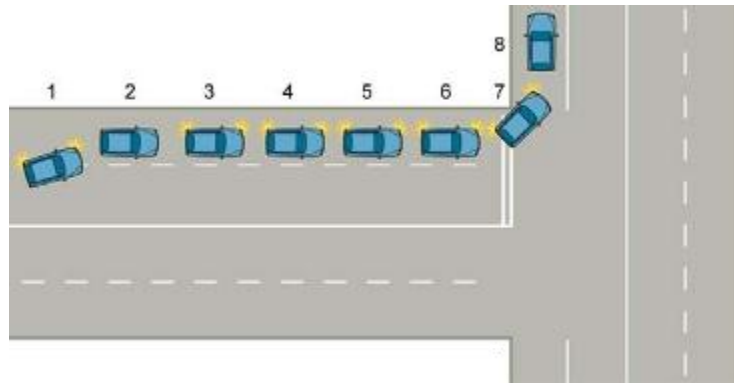

Use this memory jogger to remember and teach the sequence of the system of car control.

Can My Safety Be Given More Effective Attention.

## Blind zones and view blockers

The field of view available to a driver is divided into zones where driver vision is unaffected and where driver vision is obscured. The view through the windscreen, to the immediate rear in the rear-view mirror, and to the sides through the driver and passenger windows, will generally be very good. However there are blind zones, created by the vehicle itself (vehicle pillars), and view blockers (outside obstructions to driver vision) that can, and often do, obscure potential hazards. This is a very good reason to apply the observation skills already discussed.

The influence of these blind zones and view blockers on hazard recognition can be managed by applying a few simple observation rules.

To minimise the risks of blind zones, drivers must always conduct over the shoulder checks before leaving the kerb, parking, merging with other traffic, turning or changing lanes. They should also position their vehicles to maximise the effectiveness of rear view mirrors and to allow faster traffic to always pass on the right hand side.

View blockers can be addressed by initially positioning the vehicle to the outside of the turn, before cornering to see further into the corner, by adopting correct lane positions in intersections, by staying back (2 and 4-second rules) when following large vehicles and by reducing speed before entering any situation where vision is obscured.

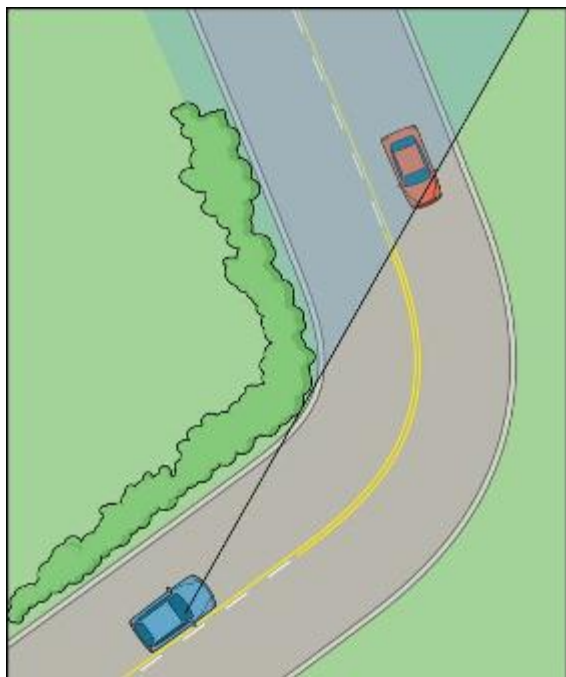

Left hand bend/ right lane position

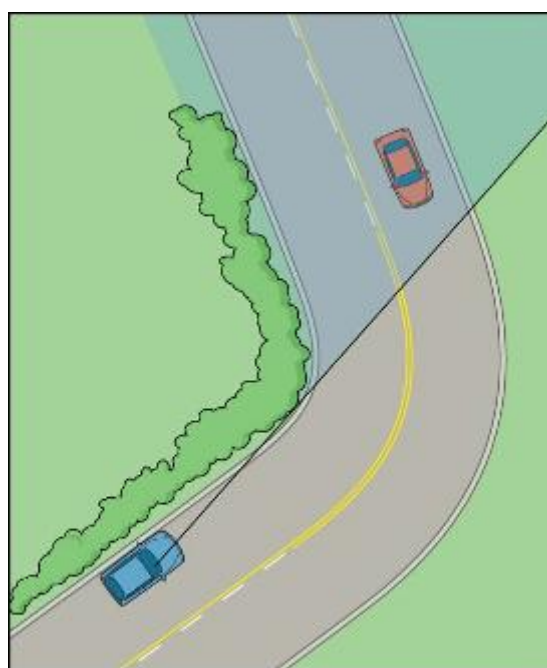

Left hand bend/ left lane position

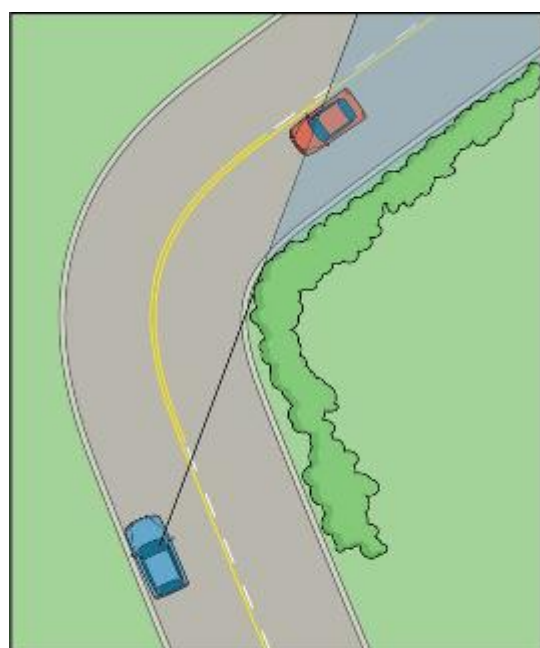

Right hand bend/ left lane position

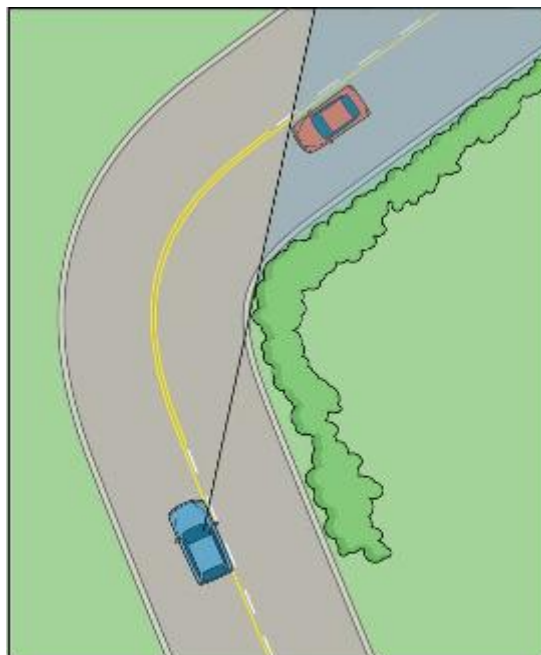

Right hand bend/ right lane position

A common view blocker at intersections is another larger vehicle alongside that blocks the line of sight to the right or left. There is a commonly held misconception among many drivers that, even though their view of any approaching traffic is obscured, they can move off safely from the intersection when the larger vehicle does so. This 'shadow effect' is fraught with danger as it relies on the judgement of the other driver and, if that driver changes their mind and suddenly stops, can leave the unsuspected vehicle exposed to a serious crash situation. Shadowing other vehicles must be discouraged at an early stage in training.

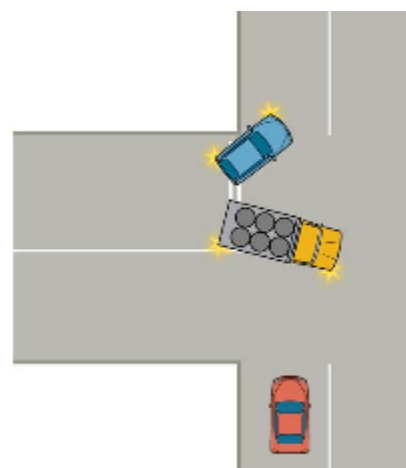

Shadow effect

Detecting and interpreting available clues when searching and scanning the road ahead, to the side and behind us requires drivers to be alert and observant. The driving task requires constant concentration and undivided attention. A driver who is constantly talking to passengers or admiring the scenery is not applying the concentration required to drive safely, particularly in busy traffic or road conditions.

An observant driver takes advantage of open spaces and breaks in hedges, fences or walls to maximise observation through corners and when approaching intersections.

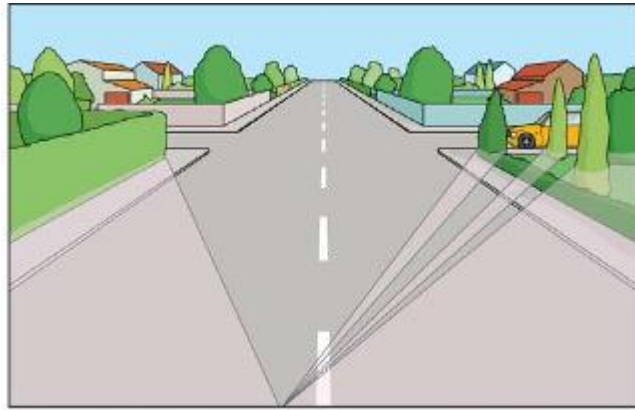

Maximising observation

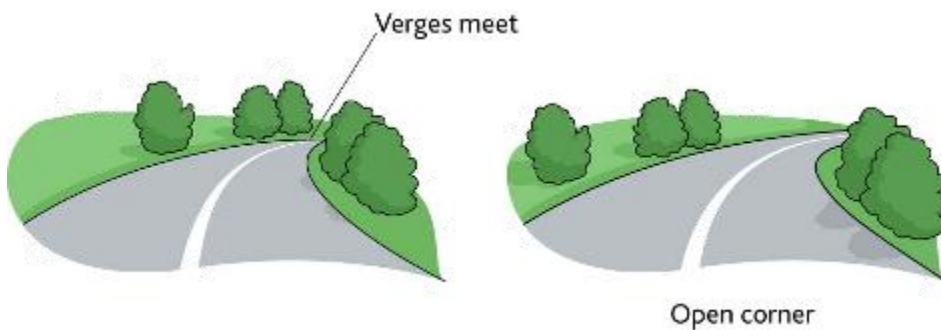

Bends in the road can restrict vision but the problem can be alleviated, to a degree, by the driver noting the position and colour of marker posts and speed advisory signs while maintaining correct lane position. The 12-second scan should have the driver looking as far into the corner as possible. This is the point

where the left and right verges of the road appear to meet. Only when the verges begin to separate again does the driver know that the severity of the corner is reducing.

Often, a driver's ability to perceive a potential hazard will be adversely affected by delayed perception. In general the causes of delayed perception tend to be:

- inexperience
- the driver not paying attention to the driving task
- obstruction to vision caused by environmental issues, view blockers and blind zones.

Specific examples may include:

- the driver failing to wear prescription glasses
- dirty windscreen or mirrors
- poor positioning of mirrors
- internal and external distractions
- incompatible driver/vehicle matching
- improper seat adjustment
- other vehicles, buildings, trees, fences etc
- visibility
- sun strike, headlight glare
- poor search and scan techniques
- corners and hills.

The influence of speed on hazard recognition should not be underestimated. As speed increases, peripheral vision decreases so it becomes critical for drivers to keep their eyes moving and be aware of the 'big picture' at all times.

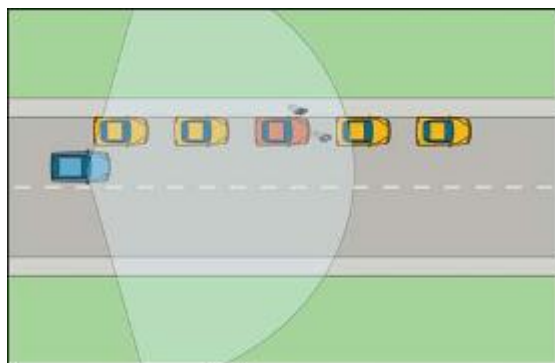

Obstructed view

Perception/reaction time, the time it takes to identify and react to a hazard, is adversely affected by speed, especially if the driver is distracted or their view is obstructed.

Colour detection, an aspect of hazard recognition, is affected by both light conditions and speed. As ambient light levels reduce, so too does the influence of colour, especially at a distance. A red car in low light conditions, for example, just becomes a dark coloured car. Excessive speed, particularly if the driver is not using correct scanning techniques, causes colours, and detail, in peripheral vision to 'wash out' and become less conspicuous.

In simple terms, excessive speed reduces the driver's ability to process information quickly enough to react to many of the driving hazards. When this deficiency is applied to over-confident young drivers with limited experience, undeveloped perceptual skills and poor hazard awareness, the risk of serious crashes increases dramatically.

Light conditions can also affect observation. Zones of vision can be limited to the 'throw' of the headlight beam and street lighting and can be temporarily, but seriously, affected by headlight glare from oncoming vehicles. Sun strike, early or late in the day, can also cause serious problems for a driver's ability to discern problems ahead. The ability to react to hazards is totally dependent upon what the driver can see. At night this is seriously limited and vehicle speed may need to be reduced so that the vehicle can be stopped safely within the limits of the headlight beam. Bright light in the driver's eyes, whether by day or night, removes detail. For example, a vehicle running on park lights at dusk and travelling in a queue of traffic, will become almost invisible if the vehicles around it have their headlights on. During the day, with the sun low in the sky and behind oncoming vehicles, those vehicles will also become almost invisible. The solution to both these problems is for the oncoming vehicles to turn their headlights on and become more visible.

## Gap selection

Driving instructors and their trainees must remember that driving is a task that includes the management of time and space. There is only a limited amount of space available to drivers on New Zealand's roads and when two vehicles try to occupy the same piece of road space at the same time, a crash will occur! It stands to reason then that not only does the driver have to maintain correct road position and following distances, but when they want to overtake, move through an intersection or cross another vehicle's path, there is only a limited amount of space and time to do so. This 'gap selection' should allow any manoeuvre to be completed safely without causing other drivers to adjust their speed or direction.

The 'gap' is the distance between the manoeuvring vehicle and other traffic estimated in seconds or metres. It can never be a precise calculation because people's perceptions of time and distance vary greatly. It also presumes that other drivers are abiding strictly by the speed limits (which is sometimes not the case) and that they will, at all times, meet their other general driving obligations such as maintaining correct road position, applying correct following distances and signalling their intentions. Gap selection will be adversely affected by vehicles exceeding posted speed limits as both time and distance calculations become more ineffective as closing speeds increase.

Gap selection improves with driving experience but some basic time and distance facts need to be understood.

- When moving off and turning left from an intersection, it will take about 8-10 seconds to accelerate steadily to 50km/h and about 20 seconds to 100km/h.

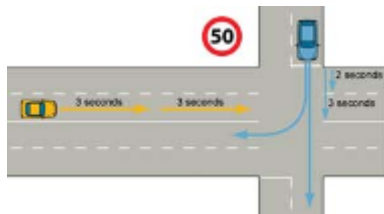

- On leaving a stop sign, under normal acceleration, it will take about two seconds for a car to cross the first lane of an intersection and about one second for each lane after that.

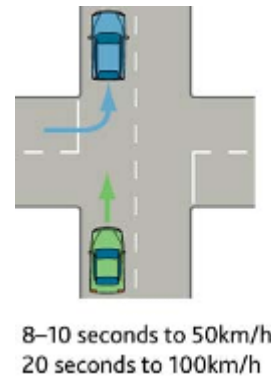

- A truck and trailer in the same situation will require about three seconds for each part of the combination in the first lane (six seconds) and about two seconds for the whole combination in each lane after that.
- For every 10km/h of speed a vehicle covers 2.7 metres every second. This means that at 100km/h a vehicle covers 27 metres per second and at 50km/h about 14 metres per second.
- At 100km/h the driver of a car would need nearly 80 metres of clear road to identify a problem and bring the vehicle to a stop. ( A truck, because of its much greater weight, and the effects of kinetic energy, would require exponentially more distance to do the same.) At 50km/h the car driver would need about 25 metres to identify a problem and come to a stop.

- Traffic law states that when overtaking, a driver must have at least 100 metres of clear road ahead of them throughout the whole manoeuvre. It takes approximately 12 seconds to overtake safely so at 100km/h this equates to about 320 metres plus the 100 metres required at the end of the passing manoeuvre. A total of 420 metres!



A driver's average reaction time to a hazard is about 3/4 of a second. At 100km/h this is about 20 metres on the road and at 50km/h, about 10 metres. Reaction times can be much longer if a driver has to make a decision about what to do. For example 'Shall I brake or steer around the hazard?'

- To reaction time must be added braking distance. At 50km/h this will be about 15 metres and at 100km/h, four times this, at 60 metres.
  - 100 metres, a commonly distance reference in driving, is the length of a football or rugby field. A four second gap in traffic in a 50km/h area is about half the length of a football field. On the open road, four seconds is the length of a football field.



- Road marker posts on the sides of straight roads tend to be about 100 metres apart and can provide a rough guide to distance.

These considerations can influence a driver's decisions, consciously or not, when carrying out a variety of manoeuvres where the potential for conflict with other traffic exists.

Developing gap selection skills takes practice. By encouraging trainees to observe the 2 and 4-second rules for following distances, for example, they quickly begin to appreciate the relationship between time and distance. Opportunities for trainees to estimate these between clearly defined points should be taken regularly both in and out of the vehicle.

Gap selection is not an 'exact science' but rather a critical safe driving skill that develops quite quickly provided the instructor incorporates the concept into training at an early stage.

## Distractions

Driver distraction is a common contributing factor in many road crashes. The issue has to be addressed at an early stage in driver development so that the serious risks associated with them are minimised. As driver confidence and ability improves there is a tendency for outside influences to start creeping in. While some distractions, like monitoring gauges are to be expected, many others can be managed with a little forethought and consideration to the possible consequences.

### Internal distractions

These are distractions that occur inside the vehicle that relate either directly to the driver, to the car or to passengers. They include apparently minor tasks such as lighting cigarettes, changing a CD and eating or drinking. This type of distraction can be managed by planning ahead and choosing the right time and place.

Of a more serious nature are distractions such as mobile phones ringing or unruly or noisy passengers, particularly children. If a mobile phone does ring it must not be answered by the driver (unless it can be operated using a hands free device). The driver must find a safe and legal place to stop and park before answering the call. Turning the phone off while driving is therefore the most sensible option to avoid any distraction. No call or message is that important that lives need to be put at risk.

Children must, by law and in terms of parental responsibility, be restrained in a vehicle so there shouldn't be any issues relating to them moving around in a car. If they become noisy or start misbehaving, the only option, once again, is to pull over and stop until the problem has been sorted. On long trips children should have access to snacks and drinks and any activities that can distract them but not the driver.

### External distractions

External distractions are those that occur outside the vehicle and include scenery, advertising hoardings, street signs, other road users including pedestrians and animals, weather and temperature effects.

The key message for trainees is that they must concentrate on the driving task and, if any of these distractions require rectifying or further investigation, then they should pull over and stop. If looking for street addresses, drivers should move over to the left, slow down and consider the effects of their driving on following traffic.

## Road craft

The term 'road craft' has been used periodically in this manual and is worthy of some explanation as it relates to a driving standard to which all drivers should aspire. Road craft is the effective application of driving knowledge and skills in a manner that reflects an appreciation of the risks associated with driving and their effects on other road users. This takes time and experience to develop and the driver must be able to anticipate what effects his/her actions, or inactions, will have on the traffic scene and what effect the actions or inactions of other drivers will have on them. Road craft, applied at its highest level, requires familiarity with the vehicle being driven, a sound understanding of the road rules, total concentration on the driving task and a courteous, responsible driving style.

Examples of road craft being applied might include:

- indicating early prior to making a turn because of tail-gating traffic
- considering the possible effects of, and on, other traffic before turning on or off a highway
- using the foot brake, rather than the park brake, when stopped at intersections because this will illuminate the brake lights and apply all of the brakes, not just the rear ones
- driving at speeds that reflect the driving conditions, which may not necessarily be at the maximum posted speed limits
- maintaining the vehicle in a safe mechanical condition
- avoiding unnecessary distractions like mobile phones by turning them off when driving

- understanding that the legal driving obligations have to be met consistently, at all times, not just when the driver thinks it might be necessary.

## Section 6: Individual lesson plans (car)

### Introduction

This section of the *Learning system for driving instructors* offers you a resource that can be used to complement or, if preferred, replace existing training material. The intention is not to dictate teaching style or the method of delivery but rather to identify the learning and assessment points that might be relevant to individual trainees. Each performance objective addresses a specific skill and/or knowledge set that, in light of current technology, can be used for either novice or more experienced trainees. This allows driving instructors and trainers to select the performance objectives, and the learning points within them, to suit specific needs, whether that relates to preparation for driver licence testing or organisational in-house introductory or remedial training.

Performance objectives continue to be a simple means of identifying what a trainee must achieve, to what standard and with what resources. The concept of explanation, demonstration and practice has particular relevance in driver instruction where repetition develops skills and knowledge and where visual and kinaesthetic learning play primary roles.

### Layout

While these lessons contain much of the information included in the original LSFDI, the basic layout for each objective has been standardised and includes the following:

- a. Space for the name of the trainee, the location of training and the training vehicle details.
- b. An introduction that provides some information that you can build upon to commence a lesson.
  - c. Tranzqual ITO publication references that might offer you some additional information or provide study material for the trainee. These references can be downloaded free of charge from [www.tranzqual.org.nz](http://www.tranzqual.org.nz). Select 'Training and assessment' then navigate to 'Downloads and forms'. Enter the unit standard number to access the appropriate study guide.
- d. The performance required of the trainee, the standards that must be achieved by the trainee to be judged as competent and the conditions that must be provided for that to occur.
- e. Recommended revision, which should be a component of any lesson.
- f. A reminder to you to demonstrate each learning point, explain your actions and the reasons for doing them in the way you have and to have the trainee practice each learning point as often as possible (explain - demonstrate - practice).
- g. Each performance objective is broken down into learning points that should be addressed through instruction and then assessed. As these are completed the date and your initials are entered. Each learning point is numbered for easy reference. 13-2e for example, relates to objective 13 (steep grades) learning point 2e (overtaking during ascents). 2-2b relates to objective 2 (cabin drills) learning point 2b (moving the shift lever to park or neutral when shutting down).
- h. Comments can be added, as appropriate, during and at the conclusion of any lessons or assessments. These latter comments should include, by reference, any learning points that need to be revisited.
- i. Instructor's notes provide a raft of information that has relevance to achieving the objective. You can add your own notes to these as required.
- j. Common faults, symptoms of those faults and suggested responses to them are also provided but additions can be made to this list to reflect personal experiences and knowledge.

Each performance objective has been presented as a lesson plan and they can be used as such or simply as a reference for use with in-house resources. Photocopying will produce individual lesson plans that can be adapted

to meet individual or company training needs. Those sections of the documents that are not relevant should be marked 'NA'. The detail of these documents reduces the detail required on the individual training record included in this section. These documents together provide ample evidence of training undertaken which would satisfy NZTA auditing requirements. While the disposal of lesson plans must meet NZTA guidelines for the retention of records, the individual training record would become a permanent record, available for reference at much later dates.

While many learning points appear to be repeated across a range of objectives, this is deliberate as each document is designed to stand on its own as well as being part of a larger training programme. A novice driver, someone hoping to gain a class 1 driver licence will need to start off with the basic lessons and progress gradually through to the more advanced lessons. A more experienced driver, someone who already holds a full or restricted class 1 licence, might only need to receive instruction in some of the more advanced lessons or components of them.

The more advanced performance objectives reflect the six driving conditions from which all potential hazards arise. This allows you to focus on specific aspects of trainee risk management.

One point to consider is that as young drivers progress through the graduated licensing system, many will have very little, if any, experience with manual transmissions. This means, in effect, that those who do wish to be taught in a car with a manual transmission will likely require more time to achieve objectives. This must be factored into a learner's training programme. The duration of an individual's training cannot be pre-determined just to meet the commercial demands of the driving school or training provider. Each trainee will have specific training needs and some will progress much quicker than others. At the completion of training a competent student should be able to consistently achieve all of the relevant learning points set out in this section. Where this is achieved, success in the practical driver licensing tests should follow.

For instructors preparing trainees for the restricted or full class 1 driver licence test, reference should be made to, and assessments made against, the NZTA publications *Driver training syllabus: Learner stage - Preparing for the restricted licence test* and *Driver training syllabus: Restricted stage - Preparing for the full licence test*.

Copies can be ordered at: [www.nzta.govt.nz/resources/order/](http://www.nzta.govt.nz/resources/order/).

The lesson plans contained in this section are also supported by a selection of blank road layouts (in the back of this manual) which you may choose to laminate and use during training to enhance lesson delivery.

## Individual training record

Trainee name	
Address	
Driver licence number	
Licence expiry date	
Phone	
Classes held	
Date of birth	
Driving school reference number	

	Performance objectives	Learning points	Comments	Date completed	DI initials
1	Pre-driving checks	General			
		Under bonnet checks			
		Interior checks			
		Exterior checks			
2	Cabin drills	Starting the engine.			
		Shutting down the engine			
3	Moving off and stopping – straight ahead	Moving off			
		Stopping			
4	Steering	Steering			
5	Moving off and stopping – at an angle	Moving off			
		Stopping			
6	Signals	Use of indicators			
7	Basic gear changing	Changing up			
		Changing down			
8	Automatic transmissions	Automatic			
9	Hazards and system of vehicle control	Hazards			
		Observation			
		Hazard action plan			
		System of vehicle control			
10	Intersection techniques	General			

		Uncontrolled turning left			
		Uncontrolled turning right			
		Controlled turning left			
		Controlled turning right			
		Controlled straight through			
		Roundabouts			
11	Cornering	General			
		Cornering technique			
		Cornering line right			
		Cornering line left			
12	Moving off – up hill and down hill	Moving off up hill			
		Moving off down hill			
13	Negotiating steep grades	General			
		Steep ascents			
		Steep descents			
14	Overtaking and use of passing lanes	General			
		Overtaking			
		Passing lanes			
15	Town driving	General			
		Road conditions			
		Traffic conditions			
		Vehicle conditions			
		Weather conditions			

		Light conditions			
		Driver conditions			
16	Motorway driving	General			
		Road conditions			
		Traffic conditions			
		Vehicle conditions			
		Weather conditions			
		Light conditions			
		Driver conditions			
17	Rural/open road driving	General			
		Road conditions			
		Traffic conditions			
		Vehicle conditions			
		Weather conditions			
		Light conditions			
		Driver conditions			
18	Night driving	Night driving			
19	Reversing	Straight back			
		90 degrees right			
		90 degrees left			
20	Emergency stops	Progressive braking			
		Cadence braking			
		ABS			

21	Parallel parking	Parallel park			
		Exit a parallel park.			
22	U-turns and three-point turns	U-turns			
		Three-point turns			

## Lesson plans

### 1 Pre-driving checks

1	Pre-driving checks
Trainee name	
Location	
Vehicle details	
<p>This first competency develops the ability to conduct comprehensive pre-trip inspections and should allow trainees to gain confidence through knowledge and vehicle familiarisation and develop an appreciation for vehicle empathy and safety. A checklist has been provided for the trainee's use.</p>	
<p>References: <a href="#">Tranzqual ITO Study Guide US17676</a> Carry out pre-drive vehicle checks on a light motor vehicle and start and shutdown the vehicle.</p>	
Performance	Conduct pre-trip checks on a light motor vehicle.
Standard	<p>Without assistance.</p> <p>In a logical sequence.</p> <p>In repeated trials.</p> <p>Without omitting any inspection points.</p> <p>Correctly answering any questions posed by the instructor.</p>
Conditions	<p>On a light motor vehicle.</p> <p>In daylight or good artificial light.</p> <p>In a safe area away from other traffic.</p> <p>With a checklist.</p>
Revision	Nil

## Explain - demonstrate - practice

1. Learning points (general)		Comments	Date completed	DI initials
a.	Explains reasons for conducting pre-trip inspections.			
b.	Where necessary refers to the driver's handbook.			
c.	Applies personal safety precautions.			
d.	Follows a logical sequence for checks.			
e.	Records and/or rectifies any faults on the vehicle checklist.			
2. Learning points (under bonnet checks)		Comments	Date completed	DI initials
a.	Checks engine oil level for level (between 'add' and 'full') and colour.			
b.	Checks power steering oil level and condition.			
c.	Checks coolant level and condition (additives).			
d.	Checks condition and security of hoses.			
e.	Checks condition and tension of belts.			
f.	Checks for general leaks around engine.			
g.	Checks brake fluid level.			
h.	Checks automatic transmission fluid level (where appropriate).			
i.	Checks windscreen washer fluid level and additive.			
j.	Checks battery for fluid level, corrosion and security.			

3. Learning points (interior checks)		Comments	Date completed	DI initials
a.	Checks park brake on/gear shift in neutral.			
b.	checks warrant of fitness, vehicle licence and RUC licence (if appropriate) are current and displayed correctly.			
c.	Checks rear-view mirror adjustment and cleanliness.			
d.	Checks seat position so that lower back is fully supported and arms are slightly bent when holding the steering wheel correctly.			
e.	Checks position of steering wheel and adjusts where appropriate.			
f.	Checks seat belts for damage and operation (retractor, coupling).			
g.	Turns key to 'acc' position.			
h.	Checks operation of wipers and washers even if not raining.			
i.	Checks for cleanliness of windscreen and windows.			
j.	Checks operation of horn.			
k.	Checks door releases and locks for operation.			
4. Learning points (exterior checks)		Comments	Date completed	DI initials
a.	Checks headlights, tail lights, brake lights, indicators and number plate light for operation, damage and cleanliness.			
b.	Checks tyres for side wall damage, pressure and tread.			
c.	Checks for loose wheel nuts and visible damage.			

d.	Checks for panel and/or glass damage.
e.	Checks for oil and water leaks under vehicle.
f.	Checks condition and security of spare wheel and tools.
g.	Checks security of registration plates.

### Instructor's notes

1.	Reasons for checks include personal safety, safety of other road users, legal requirements and vehicle empathy.
2.	Encourage reference to manufacturer's driver's handbook. Where possible, ensure a copy of the driver handbook is available for the vehicle being used.
3.	Explain that these full checks are not likely to be conducted every day but that they should be conducted at least weekly if the vehicle is getting a lot of use. Water and oil should be checked every time the vehicle is refuelled.
4.	Demonstrate and explain, in detail, each inspection point.
5.	When assessing the lesson, ask questions to confirm the trainees understanding of the tasks.
6.	Retain the trainee's inspection checklist as part of the trainee record.
7.	Emphasise the need to note and rectify all faults so that the vehicle always meets the WoF standard.
8.	Ensure adequate tools and equipment are at hand to conduct all check

Common faults	Symptoms	Address/check
Misses specific checks.	Checklist items not marked.	A logical sequence is followed and checklist used correctly.
Insufficient attention to detail.	Fails to identify fault.	Understanding of checks to be conducted. Importance of / reasons for all checks.

## Pre-drive inspection checklist

Date							
Location							
Vehicle registration							
Make/model							
Odometer start							
Vehicle licence expires							
WoF/CoF expires							
RUC licence expires							
Under the bonnet							
	Check	√	x		Check	√	x
1	Coolant			6	Windscreen washer		
2	Engine oil			7	Hoses		
3	Brake fluid			8	Belts		
4	Power steering			9	Automatic transmission fluid (if applicable)		
5	Battery			10	Leaks		
Outside the vehicle							
	Check	√	x		Check	√	x
11	Body panels and leaks			18	Number plate lights		
12	Wheel nuts			19	Spare wheel and tools		
13	Tyres			20	Registration plates		
14	Windscreens/ windows						
15	Headlights/tail lights						
16	Indicators						
17	Brake lights						
Inside the vehicle							
	Check	√	x		Check	√	x
21	Park brake on/in neutral			29	Door release/locks		
22	Seat belts			30	Vehicle documents		
23	Seat position			31	Cleanliness of windscreen and windows		
24	Mirrors						
25	Wipers						

26	Windscreen washer			
27	Horn			
28	Steering wheel			

Damage or faults

Ser #	Description

Driver's name \_\_\_\_\_ Signature: \_\_\_\_\_

## 2 Cabin drills

2	Cabin drills
Trainee name	
Location	
Vehicle details	
<p>It is important that trainees understand that each vehicle, depending on manufacturer, may differ in dashboard layout, particularly in relation to control positions and complexity. Light vehicles all share common internal features but rapidly developing technology demands a more methodical and detailed approach to the training of new drivers who must understand, and be able to confidently operate, that technology.</p>	
<p>References: Tranzqual ITO study guide US17676 Carry out pre-drive vehicle checks on a light motor vehicle and start and shutdown the vehicle.</p>	
Performance	Demonstrate correct procedures for starting and shutting down a light motor vehicle.
Standard	<p>Without assistance.</p> <p>In the correct sequence.</p> <p>In repeated trials.</p> <p>Without omitting any points.</p> <p>While observing the manufacturers requirements or recommendations.</p> <p>Correctly answering any questions posed by the trainer.</p>
Conditions	<p>In a light motor vehicle.</p> <p>In daylight or good artificial light.</p> <p>In a safe area away from other traffic.</p>
Revision	Performance objective 1: Pre-driving checks.

Explain – demonstrate – practice

1. Learning points (starting the engine)		Comments	Date completed	DI initials
a.	Ensures park brake is applied.			
b.	Checks gear shift lever is in 'neutral' (or 'park' if fitted with an automatic transmission).			
c.	Adjusts seat and steering wheel, if necessary, so that lower back is supported and arms are slightly bent when on the steering wheel.			
d.	Checks doors are closed. Does not lock these.			
e.	Adjusts mirrors if necessary so that a clear view is provided to the rear (rear-vision mirror) and down both sides of the vehicle (side mirrors).			
f.	Checks location and position of all controls. If in an unfamiliar vehicle, familiarises with operation of all controls.			
g.	Checks operation of seatbelt including retractor and couplings and fastens seatbelt.			
h.	Switches on ignition key and observes all gauges and warning lights.			
i.	Depresses the clutch (if fitted) to reduce transmission drag when starting (releases once the engine has started).			
j.	Starts the engine and allows it to idle with the right foot clear of the accelerator.			
k.	Checks that the engine oil light goes out. If this does not happen, immediately switches the engine off.			
l.	Checks instrument readings and notes any incorrect responses.			
m.	Ensures there is sufficient fuel for the journey.			
2. Learning points (shutting down the engine)		Comments	Date completed	DI initials
a.	Applies foot brake and depresses clutch pedal (if fitted).			
b.	Moves shift lever to 'neutral' or 'park'.			

c.	Applies park brake.
d.	Turns the engine off and removes the ignition key.

Comments:

### Instructor's notes

1.	Explain and demonstrate all actions required of trainee. Observe trainee actions from the passenger's seat.
2.	Explain and, where necessary, demonstrate the function and operation of all controls, gauges and switches on the training vehicle. Emphasise importance of familiarisation before operating an unfamiliar vehicle.
3.	Explain reason for not locking doors is to allow access in event of an emergency.
4.	Explain the reasons why the clutch is depressed before starting the engine (car not in gear) to reduce the drag of the transmission when starting and to ensure the engine is not started with the transmission engaged.
5.	Explain the legal requirements for the wearing of seatbelts by driver and all passengers.
6.	Explain that in automatic vehicles, select 'Neutral' or 'Park' before switching on ignition and apply footbrake before selecting 'D' or 'R' using right foot. Emphasise that left foot is redundant when driving an automatic vehicle.
7.	Explain importance of checking manufacturers handbooks for correct starting procedures and to identify controls and instruments.

Faults	Symptom	Check/address
Seat not correctly adjusted.	Sitting too low, arms straight, hunched forward, poor vision, cannot reach controls.	Seat height and/or position.
Mirrors not correctly adjusted.	Leaning forward to check mirrors.	Adjustment of mirrors with trainee in correct seated position.
Windows dirty or obscured.	Unable to see clearly through windscreen or side windows.	Clean all windows, check operation of air-con or demisters.
Unfamiliar with vehicle starting procedure.	Does not check park brake or gear-shift lever position.	Starting procedure for vehicle being driven.
Right foot on throttle during start-up.	Over-revving.	Switch engine off and run through procedure again.

Fails to fasten seat belt.	Tries to fit seatbelt after starting to move off.	Stop and rectify.
Doors not properly closed.	Interior light on, warning gauge on, door rattling.	Stop and rectify.
Operating brake with left foot.	Uncoordinated brake/accelerator control. Movement of left foot or failure to move right foot.	Explain reasons for using right foot for braking include excessive brake wear due to resting foot on brake pedal, poor throttle coordination.

### 3 Moving off and stopping – straight ahead

3 Moving off and stopping – straight ahead	
Trainee name	
Location	
Vehicle details	
Transmission	
<p>While this lesson is fairly straight forward in a vehicle fitted with an automatic transmission, it becomes somewhat more complex if the new trainee is operating a manual transmission. Instructors must be mindful of the coordination issues that exist and be prepared to focus solely on this before assessing the lesson as a whole. Because of the difficulties encountered by some trainees in these initial driving lessons, 'stopping' has been included so that, should the trainee need to stop the vehicle and move off again, the activities are completed safely with due regard for other road users. This lesson might very well be conducted concurrently with lesson 6: Basic gear changing.</p>	
<p>References: Tranzqual ITO study guide US3469 Apply control in driving a light motor vehicle.</p>	
Performance	Demonstrate the ability to move off in a straight line from a stationary position and, after moving off, bring the vehicle to a complete stop.
Standard	<p>In the correct sequence.</p> <p>Without stalling.</p> <p>Without over-revving the engine.</p> <p>In repeated trials.</p> <p>While meeting all legal obligations.</p>
Conditions	<p>In a light motor vehicle.</p> <p>In daylight.</p> <p>On level ground.</p> <p>On a manoeuvring area without other road users.</p>
Revision	Performance objective 2: Cabin drills

Explain –demonstrate – practice

1. Learning points (moving off) - manual		Comments	Date completed	DI initials
a.	Ensures the vehicle is ready to move off with all doors closed, seatbelt worn and engine running.			
b.	Depresses clutch with left foot.			
c.	Selects first gear.			
d.	Checks rear-view mirrors to ensure road behind is clear. Check over shoulder into blind spot.			
e.	Depresses accelerator slightly with right foot to increase engine speed.			
f.	Checks rear-view mirrors again.			
g.	Releases clutch pedal slowly until engine note changes and drive is starting to engage.			
h.	Ensures road ahead is clear.			
i.	Releases park brake, returns hands to steering wheel.			
j.	Depresses accelerator slowly to increase engine speed and slowly releases the clutch while looking ahead.			
k.	Ensures left foot is clear of the clutch pedal and that the hands are in the correct position on the steering wheel.			
l.	Gently accelerates vehicle in a straight line.			
1. Learning points (moving off) - automatic		Comments	Date completed	DI initials
a.	Ensure the vehicle is ready to move off with all doors closed, seatbelt worn and engine running.			
b.	Place right foot on brake pedal.			
c.	Select drive.			
d.	Check rear-view mirrors to ensure road behind is clear. Check over shoulder into blind spot.			
e.	Release park brake and return hands to steering wheel.			

f.	Depresses accelerator slowly to increase speed.			
g.	Ensure that hands are in correct position on steering wheel.			
h.	Gently accelerate vehicle in a straight line.			
<b>2. Learning points (stopping)</b>		<b>Comments</b>	<b>Date completed</b>	<b>DI initials</b>
a.	Selects a safe place to stop.			
b.	Checks rear view mirrors for following traffic.			
c.	Removes right foot from accelerator and gently applies foot brake to slow down.			
d.	Maintains two handed steering.			
e.	In the last few metres, just prior to stopping, depresses the clutch with the left foot (manual) and brings the vehicle to a complete stop on the foot brake.			
f.	Applies the park brake.			
g.	Moves the gear lever into neutral (manual) or 'park'. (automatic).			
h.	Turns the vehicle off, if required.			

Comments:

### Instructor's notes

1.	Select initial training areas with care so that there is minimal interference from other road users.
2.	Take into account nervousness of trainees exposed to driving for the first time.
3.	Explain and demonstrate all activities.
4.	This lesson might very easily be combined with lessons 5 and 6 (steering and basic gear changing).
5.	Emphasise need to check blind spots and time required to match speed of other traffic.

6.	Check to ensure the trainee does not ride the clutch.	
7.	Emphasise the need NOT to rush any aspect of driving.	
8.	Check that the trainee does not ride the clutch (manual) or use left foot braking (automatic).	
9.	Expect to spend some time fine tuning coordination of both feet.	
10.	Explain braking effects of foot brake (all four wheels) and park brake (only back wheels).	
11.	Introduce trainees to effects of engine braking effect especially in lower gears.	
Faults	Symptom	Check/address
Fails to check position of gear lever prior to starting vehicle.	Vehicle jerks or fails to fire.	Use revision to eliminate this problem.
Excessive acceleration.	Races engine.	Clutch/accelerator control.
Fails to fully depress clutch pedal.	Gear clash. Gear not engaged.	Nervousness. Rushing.
Uses wrong gear to start.	Stalls engine.	Gear position.
Fails to release park brake.	Stalls engine.	Nervousness. Sequence.
Poor clutch/accelerator co-ordination.	Moves off in jerks or stalls.	Clutch/accelerator control.
Moves off without checking other traffic.	Reaction of other road users.	Nervousness. Sequence.
Coasting.	Depresses clutch before braking when stopping.	Vehicle control.
Depresses clutch too late when stopping.	Stalls engine.	Clutch/brake coordination.
Brakes too hard when stopping.	Driver / passengers thrown forward.	Brake pedal pressure control for training vehicle.
Stops too far from designated position.	Rushed, or delayed, response to instructions.	Rushing, nervousness, sequence.

## 4 Steering

4	Steering
Trainee name	
Location	
Vehicle details	
<p>The steering techniques that should be applied when driving a car have to be introduced and monitored from the commencement of this lesson onward. Modern vehicles have power steering which means that only a very few turns of the steering wheel are required from full lock to full lock but the need to maintain an efficient steering style becomes very important in these initial stages of training as it goes some way to developing safe driving practices.</p>	
<p>References: Tranzqual ITO study guide US3469 Apply control in driving a light motor vehicle.</p>	
Performance	Demonstrate the ability to steer a vehicle in a forward direction.
Standard	<p>Accurately and smoothly.</p> <p>Without inconveniencing other road users.</p> <p>In repeated trials.</p> <p>While meeting all legal obligations.</p>
Conditions	<p>In a light motor vehicle..</p> <p>In daylight.</p> <p>Over both straight and curved courses.</p> <p>On a public road or manoeuvring area.</p>
Revision	Performance objective 3: Moving off and stopping – straight ahead.

## Explain – demonstrate – practice

1. Learning points (steering)		Comments	Date completed	DI initials
a.	Seated with lower back supported and arms slightly bent when hands are on the steering wheel.			
b.	Maintains two hands on the wheel unless operating other controls.			
c.	Applies smooth steering movements.			
d.	Positions hands at 'quarter to 3'.			
e.	Demonstrates hand over hand steering method.			
f.	Demonstrates push-pull steering method.			
g.	Steers vehicle over selected course using safe, effective steering technique.			
Instructor's notes				
1.	Select initial training areas with care so that there is minimal interference from other road users.			
2.	Take into account nervousness of trainees exposed to driving vehicles for the first time.			
3.	Check trainee posture prior to commencement and ensure seating position is correct.			
4.	Candidates should be encouraged not to turn the front wheels when stationary. This places undue stress on steering components.			
5.	Any tendency to rest the left hand on the gear lever must be dealt with early.			
6.	Emphasise importance of looking well ahead to determine the path of travel. Don't look at the ground immediately in front of the vehicle.			
7.	Discourage the habit of letting the wheel spin through the hands during centering. While a common habit, this equates to non-existent steering control.			
8.	Practice both hand-over-hand and push-pull steering techniques, and encourage the use of the latter as it minimises oversteer in corners.			
9.	Do not accept low hand positions on the steering wheel or frequent one handed steering.			
10.	Explain the characteristics of the steering system including caster, toe-in and toe-out, line of travel of front and rear axles etc.			
11.	Best practice used to recommend hand position at 10 to 2. With the advent of airbags this position will result in the hands being forced into the face if the airbags are activated. For this reason 'quarter to 3 is now the accepted best practice.			

Faults	Symptom	Check/address
Incorrect hand position.	High or low hand position. Hands too close together.	'Quarter to 3' position.
Excessive one hand steering.	Hands resting on leg or left hand on shift lever or right arm resting on the door or arm rest.	Steering technique.
Oversteer or understeer.	Erratic steering movement.	Encourage 'push – pull' steering.
Both hands off the steering wheel.	Allows wheel to spin after a turn or removes both hands in physical expression.	Over-confidence. Steering technique.

## 5 Moving off and stopping – at an angle

5	Moving off and stopping – at an angle
Trainee name	
Location	
Vehicle details	
Transmission	
<p>This lesson is a continuation of lesson 3 Moving off and stopping – straight ahead and can be incorporated with it if the trainee has quickly achieved the outcomes from lesson 3 and understands the use of signals. Once again, the lesson is fairly straight forward in a vehicle fitted with an automatic transmission, but becomes more of a challenge in a car fitted with a manual transmission. This lesson might be conducted before, or concurrently with, lesson 6: Basic gear changing.</p>	
<p>References: Tranzqual ITO study guide US3469 Apply control in driving a light motor vehicle.</p>	
Performance	Demonstrate the ability to move off at an angle from a stationary position and, after moving off, pull over to the side of the road and bring the vehicle to a complete stop.
Standard	<p>In the correct sequence.</p> <p>Without stalling.</p> <p>Without over-revving the engine.</p> <p>In repeated trials.</p> <p>While meeting all legal obligations.</p>
Conditions	<p>In a light motor vehicle.</p> <p>In daylight.</p> <p>On level ground.</p> <p>On a public road or manoeuvring area.</p>
Revision	Performance objective 3: Moving off and stopping – straight ahead and 4: Steering

## Explain –demonstrate – practice

1. Learning points (moving off) - manual		Comments	Date completed	DI initials
a.	Ensures the vehicle is ready to move off with all doors closed, seatbelt worn and engine running.			
b.	Depresses clutch with left foot.			
c.	Selects first gear.			
d.	Checks rear-view mirrors to ensure road behind is clear. Check over shoulder into blind spot.			
e.	Signals intention to move out from the side of the road for at least three seconds.			
f.	Depresses accelerator slightly with right foot to increase engine speed.			
g.	Releases clutch pedal slowly until engine note changes and drive is starting to engage.			
h.	Ensures road ahead is clear and checks rear-view mirrors and blind spot again.			
i.	Releases park brake and returns hands to steering wheel.			
j.	Depresses accelerator slowly to increase engine speed and slowly releases the clutch while looking ahead.			
k.	Ensures left foot is clear of the clutch pedal and that the hands are in the correct position on the steering wheel.			
l.	Once vehicle begins to move, steers smoothly from parked position onto road way.			
m.	Gently accelerates vehicle.			
n.	Checks that signal has cancelled.			
1. Learning points (moving off) - automatic		Comments	Date completed	DI initials
a.	Ensures the vehicle is ready to move off with all doors closed, seatbelt worn and engine running.			
b.	Places right foot on brake pedal.			
c.	Selects 'drive'.			

d.	Checks rear-view mirrors to ensure road behind is clear. Check over shoulder into blind spot.			
e.	Signals intention to move out from the side of the road for at least three seconds.			
f.	Ensures road ahead is clear and checks rear-view mirrors and blind spot again.			
g.	Releases park brake and returns hands to steering wheel.			
h.	Depresses accelerator slowly to increase speed.			
i.	Ensure hands are in correct position on the steering wheel.			
j.	Once vehicle begins to move steers smoothly from parked position onto road way.			
k.	Gently accelerates vehicle.			
l.	Checks that signal has been cancelled.			
<b>2. Learning points (stopping)</b>		<b>Comments</b>	<b>Date completed</b>	<b>DI initials</b>
a.	Selects a safe place to stop.			
b.	Checks rear-view mirrors for following traffic.			
c.	Signals intention to pull over for at least three seconds.			
d.	Removes right foot from accelerator and gently applies foot brake to slow down.			
e.	Maintains two handed steering and steers smoothly out of traffic to side of road.			
f.	In the last few metres, just prior to stopping, depresses the clutch with the left foot (manual) and brings the vehicle to a complete stop on the foot brake.			
g.	Applies the park brake and cancels signal.			
h.	Moves the gear lever into neutral (manual) or 'park'. (automatic).			
i.	Turns the vehicle off, if required.			
Comments				

## Instructor's notes

1. Select initial training areas with care so that there is minimal interference from other road users.
2. On a manoeuvring area, use cones to create an obstruction around which the vehicle must be manoeuvred.
3. Take into account nervousness of trainees exposed to driving for the first time especially if other traffic is present.
4. Explain and demonstrate all activities.
5. This lesson might also very easily be combined with lessons 4 and 6 (steering and basic gear changing).
6. Emphasise need to check blind spots and time required to match speed of other traffic.
7. Emphasise importance of signals and ensuring these have cancelled due to 'shallow' nature of turns.

Faults	Symptom	Check/address
Fails to check position of gear lever prior to starting vehicle.	Vehicle jerks or fails to fire.	Use revision to eliminate this problem.
Excessive acceleration.	Races engine.	Clutch/accelerator control.
Fails to fully depress clutch pedal.	Gear clash. Gear not engaged.	Nervousness. Rushing.
Uses wrong gear to start.	Stalls engine.	Gear position.
Fails to release park brake.	Stalls engine.	Nervousness. Sequence.
Poor clutch/accelerator coordination.	Moves off in jerks or stalls.	Clutch/accelerator control.
Moves off without checking other traffic.	Reaction of other road users.	Nervousness. Sequence.
Coasting.	Depresses clutch before braking when stopping.	Vehicle control.
Depresses clutch too late when stopping.	Stalls engine.	Clutch/brake coordination.
Brakes too hard when stopping.	Driver/passengers thrown forward.	Brake pedal pressure control for training vehicle.
Stops too far from designated position.	Rushed, or delayed, response to instructions.	Rushing, nervousness, sequence.
Fails to signal.	Reactions of other drivers.	Sequence.

## 6 Signals

6 Signals	
Trainee name	
Location	
Vehicle details	
<p>The only true means of communication drivers have with each other is through the use of vehicle signals. A vehicle's indicators will provide information as to the driver's intentions but their use must be consistent, irrespective of traffic conditions, and should be developed as a professional driving skill that reduces the risk of on-the-road conflict. While the law is quite clear on when vehicle signals must be given, drivers should be prepared to use them not just to meet legal obligations but whenever they change direction or lane position and at any time when they cross the centre line of the road for any reason. During training, driving instructors should be encouraging and developing this very important driving skill. This lesson will probably only be fully completed late in the training cycle due to the range of learning points (ie the variety of situations where signals are required).</p>	
<p>References: Tranzqual ITO study guide US3465 Describe driving hazards and risk reduction strategies and responses to driving hazards            NZTA publication: The official New Zealand road code</p>	
Performance	Demonstrate the ability to consistently indicate the intention to change direction or road position.
Standard	<p>Using the vehicle indicators. (turn signals).</p> <p>In repeated trials.</p> <p>While maintaining proper control.</p> <p>To meet all legal obligations.</p> <p>With due consideration for other motorists.</p>
Conditions	<p>In a light motor vehicle.</p> <p>On public roads/manoeuvring area.</p>
Revision	General traffic law.

## Explain – demonstrate – practice

1. Learning points (use of indicators)		Comments	Date completed	DI initials
a.	Demonstrates correct use of vehicle indicators at intersections, vehicle entrances and roundabouts.			
b.	Demonstrates correct use of vehicle indicators when pulling over or pulling out onto the road.			
c.	Demonstrates correct use of vehicle indicators when overtaking or changing lanes.			
d.	Demonstrates effective use of vehicle indicators when entering or merging from passing lanes.			
e.	Demonstrates effective use of indicators when changing direction or crossing the centre line for any reason.			
f.	Indicator use reflects an appreciation of the need to reduce risk.			
g.	Waits to ensure other traffic has reacted before carrying out any manoeuvre.			
h.	Ensures signals have cancelled after use.			
i.	Explains details of pre-start checks that will eliminate this risk and ensure indicators are working properly (cleanliness, damage, operation) and does not use hazard lights to check indicators.			
j.	Explains alternate ways of communicating with other road users. Hand/arm signals, horn, flashing lights.			

## Instructor's notes

1.	Any vehicle with faulty lights or indicators must not be used for training.
2.	Ensure indicators are clean.
3.	Encourage indicating early.
4.	Legal requirements for indicating: three-second minimum, overtaking, turning, pulling over, pulling out, changing lanes, roundabouts.
5.	Other situations for indicating: merging off passing lanes, avoiding road debris/crossing centre line.
6.	Make sure other motorists are reacting to signal before manoeuvring.
7.	Emphasise that signalling is required irrespective of traffic conditions.

8.	Explain that 'road users' include pedestrians, cyclists etc. Even a person on a footpath might need to know what a driver's intentions are.
9.	Other ways of communicating: Use of foot brake to warn following motorists of intention to slow down or stop. Use of foot brake once stopped at intersections. Use of horn as a warning (signalling) device. Use of flashing headlights as a warning device. Use of hazard lights as warning device. Hand and arm signals if indicators are not working or are obscured.
10.	Explain that stop signals are not necessary in an emergency.
11.	Use other driver's actions, or inactions, to highlight risks associated with incorrect use of signals.

Faults	Symptom	Check/address
Fails to signal intentions.	Reactions of other motorists.	Legal obligations. Over confidence. Attitude.
Signals too early.	Other drivers confused.	Legal obligations.
Signals too late.	Fails to signal for at least three seconds, reactions of other drivers.	Legal obligations.
Unclear signals.	Unnecessary or incorrect signalling.	Nervousness. Legal obligations.
Wrong signal.	Signals right instead of left or vice versa. Faulty electrical connection.	Route planning. Pre-trip inspections.
Fails to signal intention to slow down or stop.	Late braking.	Observation.
Fails to anticipate need for signalling.	Late signals, fails to signal, incorrect or confusing signals.	Observation

## 7 Basic gear changing

7 Basic gear changing	
Trainee name	
Location	
Vehicle details	
Transmission	
Probably the most difficult manipulative skill a learner driver will have to learn is the operation of a manual transmission (gearbox). Trainees will have very little, or no, experience with the transmission type and lessons will need to start at a very basic level. The conduct of this lesson will be largely dictated by the trainee's ability to coordinate the operation of clutch, accelerator and gear shift lever.	
References: Tranzqual ITO study guide US3469 Apply control in driving a light motor vehicle.	
Performance	Demonstrate correct gear changing techniques with a manual transmission.
Standard	<p>Without rushing.</p> <p>Changing up and changing down.</p> <p>Without labouring or over-revving the engine.</p> <p>Without clashing gears.</p> <p>While maintaining control of the vehicle.</p> <p>In repeated trials.</p> <p>While meeting all legal obligations.</p>
Conditions	<p>With a manual transmission.</p> <p>In a light motor vehicle.</p> <p>On public roads or a manoeuvring area.</p>
Revision	Performance objectives 4: Steering .and 5: Moving off and stopping.- at an angle

Explain – demonstrate – practice

1. Learning points (changing up)		Comments	Date completed	DI initials
a.	Explains shift pattern and gear shift lever positions.			
b.	Positions left hand (open hand) on shift lever when gear changing and returns hand to steering wheel at completion of shift.			
c.	Selects first gear to move off.			
d.	Applies effective clutch and throttle control when moving off.			
e.	Right foot eases the accelerator pedal, left foot depresses the clutch pedal. Moves gear shift lever to next higher gear position. Left foot eases clutch pedal and right foot depresses accelerator.			
f.	Correct coordination applied for each gear shift.			
g.	Does not look at gear shift lever when changing gear.			
h.	Maintains steering control.			

2. Learning points (changing down)		Comments	Date completed	DI initials
a.	Anticipates need to down shift and, where necessary, reduces speed by deceleration and braking before changing down.			
b.	Uses the tachometer (where fitted) to identify engine speed before changing down.			
c.	Right foot eases accelerator pedal, left foot depresses clutch pedal. Moves gear lever to the required gear. Left foot eases clutch pedal, right foot depresses accelerator (if required).			
d.	Returns hand to steering wheel after changing down.			
e.	Avoids excessive or unnecessary downshifting.			

f.	Brings vehicle safely to a stop from road speed using transmission and brakes.			
g.	Selects reverse only when vehicle is stationary.			
Comments				

Instructor's notes	
1.	Trainee ability will vary greatly. Match training venues to trainee ability.
2.	Be patient. Once gear changing has been mastered, training will likely progress quickly.
3.	Explain the purposes and advantages of a manual gearbox.
4.	Explain the function of the clutch and the consequences of 'riding' the clutch when stationary or between gear changes.
5.	Explain effects of engine braking during deceleration and that there is usually no need to change down to a gear lower than third when stopping.
6.	Teach progressive shifting techniques. This means using only enough engine speed on each up-shift to pick up the next gear. Use the tachometer (if fitted) to highlight this.
7.	The correct gear to move off in will normally be first. If moving off down hill, then second might be appropriate.
8.	Skip shifting can be taught once competency is apparent with sequential shifting. The technique is possible with smaller vehicles. This technique allows drivers to miss gears out when gear shifting, especially when turning at relatively low road speeds.
9.	Explain that gears must not be forced. This will generally only occur when road speeds are too high and/or the clutch has not been fully depressed.
10.	Clashing will generally occur when changes are rushed and/or the clutch is not fully disengaged.
11.	Explain that coasting in neutral should not be an option.
12.	Explain basic driving obligations that will assist with smooth, efficient gear changing. (following distances, vehicle speed etc).

Faults	Symptom	Check/address
Difficulty changing gear.	Mistimed hand and foot co-ordination.	Basic gear shifting.
Not changing gear soon enough.	Over-revving.	Progressive shifting technique.
Changes gear too soon.	Vehicle labours or stalls.	Progressive shifting technique.
Selects reverse too soon.	Selects reverse before vehicle has stopped moving forward.	Potential damage to transmission.
Clashes gears.	Noise.	Basic shifting technique. Clutch operation. Rushing.
Lacks confidence.	Looks at gear shift lever when changing gear.	Confidence. Hand position and gear positions.
Fails to use tachometer.	Difficulty in changing gear.	Progressive shifting.
Coasts in neutral.	Transmission in neutral. Foot on clutch.	Slowing and stopping.
Poor knowledge of gears.	Hesitancy, selects wrong gear.	Gear positions.
Rides clutch.	Foot on clutch pedal.	Monitor.

## 8 Automatic transmission

8 Automatic transmission	
Trainee name	
Location	
Vehicle details	
Transmission	
<p>The vast majority of light vehicles, in New Zealand, operate automatic transmissions and most, but not all new drivers will use cars of this type, certainly in the early stages of their development.</p> <p>Automatic transmissions simply require the driver to select the required gear and then operate the accelerator and brake pedal. There is no clutch assembly to link the engine to the transmission but rather a torque converter (a fluid coupling) that hydraulically connects the two drive line components and allows the engine to idle without stalling. Some time should be taken to introduce trainees to the advantages and limitations of automatic gearboxes.</p>	
References: Tranzqual ITO study guide US3469 Apply control in driving a light motor vehicle.	
Performance	Demonstrate correct driving techniques with an automatic transmission.
Standard	<p>In repeated trials.</p> <p>While maintaining vehicle control.</p> <p>While meeting all legal obligations.</p>
Conditions	<p>With an automatic transmission.</p> <p>In a light motor vehicle.</p> <p>On public roads.</p>
Revision	Performance objectives 4: Steering .and 5: Moving off and stopping.- at an angle

Explain – demonstrate – practice

1. Learning points (automatic)		Comments	Date completed	DI initials
a.	Explains use of shift lever and gear positions.			
b.	Follows correct vehicle starting procedures.			
c.	Selects correct gear options for driving conditions.			
d.	Positions left foot away from brake pedal (redundancy).			
e.	Demonstrates accelerator control to change up and change down.			
f.	Demonstrates efficient manual over-ride.			
g.	Demonstrates effective and safe hill driving techniques.			
h.	Reverses the vehicle safely.			
i.	Demonstrates correct shut down and parking procedures.			
j.	'Tiptronic' function is used effectively.			

Comments

Instructor's notes	
1.	Where possible, ensure manufacturer's driver's handbook is available for the transmission being used and ensure the trainee has had time to familiarise themselves with the operating guidelines.
2.	Automatic transmission technology is improving all the time. Make sure you keep up with this and check and familiarise yourself with the transmission fitted to any unfamiliar training vehicle before commencing instruction.
3.	Ensure starting procedures are covered in detail.
4.	If the transmission has a 'tiptronic' function ensure the use of this is covered in training.
5.	Ensure trainees make the left foot redundant. Left foot braking is not acceptable.
6.	Have the trainee practice manual over-ride with the gear selector, particularly prior to descents, and encourage them to avoid just selecting 'Drive' under all driving conditions.
7.	Accelerator control includes the ability to balance the accelerator to cause the engine to change up and to change down early. The first is achieved by lifting off the accelerator and the latter by kicking the accelerator down.

Faults	Symptom	Check/address
Fails to select correct gear to move off.	Fails to accelerate.	Gear selection.
Fails to follow starting procedure.	Vehicle will not start.	Starting procedures.
Incorrect braking.	Brakes with left foot.	Right foot speed control.
Holds 'drive' position in all situations.	Excessive gear shifting.	Options.

## 9 Hazards and the system of vehicle control

9	Hazards and the system of vehicle control
Trainee name	
Location	
Vehicle details	
<p>The risks associated with driving all relate to the driver's perception of, and responses to, the hazards that arise from the six driving conditions. Every driver action is, in fact, a reaction to an event in the driving environment. If the driver fails to react to an event, the consequences can almost invariably be costly and often dangerous. The hazard detection and response skills develop with experience but trainees must be introduced to these at a very early stage in their training.</p>	
<p>References: Tranzqual ITO study guide US3465 Describe driving hazards and risk reduction strategies and responses to driving hazards and US3466 Apply risk reduction techniques and strategies while driving.</p> <p>NZTA publication: The official New Zealand road code</p>	
Performance	Demonstrate the ability to observe, assess and react to hazards while driving a light motor vehicle.
Standard	<p>Without incident.</p> <p>Without inconveniencing other road users.</p> <p>While applying the hazard action plan and system of vehicle control.</p> <p>While meeting all legal obligations.</p> <p>In repeated trials.</p>
Conditions	<p>In a light motor vehicle.</p> <p>In daylight.</p> <p>On public roads.</p>
Revision	N/A

## Explain – demonstrate – practice

1. Learning points (hazards)		Comments	Date completed	DI initials
a.	Defines a hazard.			
b.	Explains the terms 'actual' and 'potential' hazards.			
c.	Describes the six driving conditions and provides two examples of hazards arising from each.			
2. Learning points ( observation)		Comments	Date completed	DI initials
a.	Applies 12-second search pattern.			
b.	Keeps eyes moving to create a search pattern all around the vehicle (to sides, behind, ahead) avoiding a fixed stare and reliance on peripheral vision.			
c.	Checks rear-view mirrors frequently and before any manoeuvre.			
d.	Checks blind spots (over shoulder check) where appropriate.			
e.	Applies 2 and 4-second rules and observes correct speeds.			
f.	Uses vehicle lights to reflect prevailing light conditions.			
g.	Uses vehicle signals in accordance with legal requirements.			
3. Learning points (hazard action plan)		Comments	Date completed	DI initials
a.	Identifies potential hazards.			

b.	Predicts possible developments.			
c.	Decides what action to take should the hazard develop.			
d.	Acts upon that decision using the system of vehicle control.			
e.	Identifies early and reacts safely to all driving hazards.			
<b>4. Learning points (system of vehicle control)</b>		<b>Comments</b>	<b>Date completed</b>	<b>DI initials</b>
a.	Selects appropriate lane or road position to avoid hazards.			
b.	Checks mirrors to determine position of other traffic.			
c.	Signals intentions (if necessary) and observes reactions of other traffic.			
d.	Brakes to reduce vehicle speed in advance of any hazard.			
e.	Downshifts to the correct gear for any manoeuvre.			
f.	Executes the manoeuvre to avoid the hazard.			
g.	Accelerates away from the hazard.			
h.	Applies the system of vehicle control consistently in all hazard avoidance.			
Comments				

## Instructors' notes

1. As trainee confidence grows, try commentary drives as a means of assessing hazard detection skills.
2. The system of vehicle control does not have to be applied in its entirety for each hazard. Indicators, for example, may not be required or a change of course necessary.
3. A hazard is any situation that contains an element of actual or potential risk. They arise from the six driving conditions.  
An actual hazard requires immediate driver reaction to prevent an incident.  
A potential hazard becomes an actual hazard only when something else occurs. Any hazard can be negotiated successfully even if this means stopping and waiting for conditions to change.
4. The six driving conditions are: road, vehicle, driver, weather, light and traffic.
5. The required observation skills are: aim high, get the big picture, keep your eyes moving, leave yourself an out and make sure they see you.
6. The hazard action plan is: identify, predict, decide and act.
7. While much of this lesson can be assessed practically, elements of it require explanation and practical teaching. The learning points can be integrated into other lessons as required.
8. Emphasise that all driving is a series of responses to the hazards that arise from the six driving conditions and, therefore, each response will influence the degree of risk that those hazards present.
9. Anticipation is the ability, based on knowledge and experience, to predict changes in the existing driving conditions that will, or might, require a response by the driver. It takes time to develop but all practical training should be conducted with this development in mind.

Faults	Symptom	Address
Fails to negotiate hazard safely.	Breaches legal or safety requirements.	Understanding of hazard action plan and system of vehicle control. Confidence with vehicle type.
Unreasonably slow.	Inconveniences other traffic . Travels well below posted speeds limits.	Driver confidence issues.
Erratic speed.	Unnecessary changes in speed.	Familiarity with vehicle. Driver confidence.
Infrequent use of mirrors.	Unaware of following traffic. Fails to check mirrors every 5–10 seconds.	Mirror use.
Fails to identify potential hazards.	Stops suddenly.	Search technique, particularly 12-second scan.

	Violent steering avoidance.	
Fails to select correct gear for road speed.	Jerky progress. Engine labours.	Familiarity with vehicle transmission.
Fails to adjust lane position early.	Late lane changes.	12-second search. Familiarity with route.
Uncertain of obligations.	Hesitation.	Knowledge of traffic regulations. Vehicle familiarity.
Fails to give way.	Reactions of opposing traffic. Failure to observe signs.	Basic obligations.
Fails to react to hazard warning signs.	Does not take steps to deal with potential hazard.	Observation skills. Purpose of hazard warning signs.
Fails to react to mandatory signs and markings (speed, stop, no entry etc).	Does not act on advice of signs. Last moment avoidance or braking.	Basic obligations. Observation skills.
Causes inconvenience to other road users.	Travels at excessively slow speeds.	Driver confidence.

## 10 Intersection techniques

10	Intersection techniques
Trainee name	
Location	
Vehicle details	
<p>Intersections continue to account for a large proportion of motor vehicle crashes resulting in death and injury. Nearly all of these crashes are attributable to poor judgement and/or a failure to abide by simple rules. Trainee drivers must be encouraged to not only meet their legal obligations in relation to intersections (which include roundabouts) but also to appreciate the effects their vehicles can have on other road users in these busy, and potentially dangerous, road features.</p> <p>This lesson has relevance to intersections in both urban and rural settings.</p>	
<p>References: Tranzqual ITO study guide US3465 Describe driving hazards and risk reduction strategies and responses to driving hazards and US3466 Apply risk reduction techniques and strategies while driving.</p> <p>NZTA publication: The official New Zealand road code</p>	
Performance	Negotiate a range of intersections.
Standard	<p>Safely, while turning right, turning left and proceeding straight through.</p> <p>Without inconveniencing other road users.</p> <p>While applying the system of vehicle control.</p> <p>While reacting to changing conditions.</p> <p>While meeting all legal obligations.</p>
Conditions	<p>In a light motor vehicle.</p> <p>On public roads.</p> <p>Through controlled and uncontrolled intersections including roundabouts.</p> <p>In daylight.</p> <p>In repeated trials.</p>
Revision	Performance objective 9: Hazards and the system of vehicle control.

Explain – demonstrate – practice

1. Learning points (general)		Comments	Date completed	DI initials
a.	Observes all road signs and markings at intersections.			
b.	Selects correct lanes and lane positions.			
c.	Identifies, in advance, type and status of intersection controls.			
d.	Early observation of traffic lights to anticipate possible changes.			
e.	Identifies, and reacts appropriately, to traffic volume and speeds.			
f.	Abides by intersection blocking rule.			
g.	Applies, in all situations, the system of vehicle control.			
h.	Understands and applies correctly, in all intersections, the give way rule.			
i.	Holds vehicle when stationary with foot brake.			
2. Learning points (uncontrolled intersections/turning left)		Comments	Date completed	DI initials
a.	Checks mirrors (entry and exit).			
b.	Indicates, irrespective of traffic conditions.			
c.	Appropriate speed throughout turn.			
d.	Positions vehicle as close as practicable to the left and, if necessary, stops in correct position.			
e.	Searches intersection before proceeding.			

f.	Applies the give way rule and proceeds only when safe to do so.			
g.	Gap selection reflects speed and position of intersecting traffic.			
h.	Maintains correct lane position throughout turn.			
i.	Accelerates steadily and smoothly to road speed after completing turn.			
<b>3. Learning points (uncontrolled intersections/turning right)</b>		<b>Comments</b>	<b>Date completed</b>	<b>DI initials</b>
a.	Checks mirrors (entry and exit).			
b.	Indicates early, irrespective of traffic conditions.			
c.	Appropriate speed throughout turn.			
d.	Positions vehicle to left of centre line and, if necessary, stops in correct position.			
e.	Searches intersection before proceeding.			
f.	Applies the give way rule and proceeds only when safe to do so.			
g.	Gap selection reflects speed and position of intersecting traffic.			
h.	Maintains correct lane position throughout the turn.			
i.	Accelerates steadily and smoothly to road speed after completing turn.			
<b>4. Learning points (controlled intersections/turning left)</b>		<b>Comments</b>	<b>Date completed</b>	<b>DI initials</b>
a.	Checks mirrors (entry and exit).			

b.	Indicates intentions early irrespective of traffic conditions.			
c.	Adopts correct lane position to make the turn.			
d.	Appropriate speed throughout turn.			
e.	Searches intersection before proceeding (even if holding the right of way).			
f.	Obeys all controls. (give way, stop, traffic lights, police officers) and if required to stop does so in correct position.			
g.	Maintains correct lane position throughout the turn or turns into correct lane.			
h.	Accelerates steadily and smoothly to road speed after completing turn.			
<b>5. Learning points (controlled intersections/turning right)</b>		<b>Comments</b>	<b>Date completed</b>	<b>DI initials</b>
a.	Checks mirrors (entry and exit).			
b.	Indicates intentions early irrespective of traffic conditions.			
c.	Adopts correct lane position early.			
d.	Appropriate speed throughout turn.			
e.	Searches intersection before proceeding (even if holding right of way).			
f.	Obeys all controls. (give way, stop, traffic lights, police officers) and if required to stop does so in correct position.			
g.	Maintains correct lane position throughout the turn or turns into correct lane.			
h.	Any turning bays/flush medians/acceleration lanes are used correctly.			
i.	Accelerates steadily and smoothly to road speed after completing turn.			

6. Learning points (controlled intersections/straight through)		Comments	Date completed	DI initials
a.	Checks mirrors (entry and exit).			
b.	Adopts correct lane position early and holds lane through intersection.			
c.	Appropriate speed throughout manoeuvre.			
d.	Searches intersection prior to proceeding (even if holding right of way).			
e.	Obeys all controls. (give way, stop, traffic lights, police officers) and if required to stop does so in correct position.			
f.	Monitors mirrors prior to any merge point and indicates prior to merging.			
7. Learning points (roundabouts)		Comments	Date completed	DI initials
a.	Check mirrors (entry and exit).			
b.	Adopts correct lane position early and holds lane position through roundabout.			
c.	Searches into roundabouts before entering and gives way to traffic from the right.			
d.	Indicates intentions early. - If moving straight through at a roundabout does not indicate right and only indicates left to exit the roundabout when passing the entry point immediately before the required exit. - If turning left, signal left of approach and leave on until roundabout has been exited. - If turning right, signal right on approach and in the roundabout, then indicate left to exit when passing the entry point immediately before the required exit.			
e.	If there are more than two lanes, uses the left lane for turning left and moving straight through and the right lane for turning right.			

f. Negotiates, where applicable, traffic light/roundabout combinations safely.

g. Speed reflects road and traffic conditions.

## Comments

### Instructor's notes

1. This lesson comprises a number of intersection scenarios and, as a result, will probably require some organisation and time to complete.
2. Look for aggressiveness (overconfidence) and nervousness (lacking confidence) that will probably reflect degrees of experience.
3. Emphasise the need to never take it for granted that right of way will be yielded.
4. Use the system of vehicle control as the basic framework for teaching and developing these particular skills.
5. Emphasise the risks associated with heavy vehicles in intersections, as a result of their tracking and rate of acceleration. Explain the tendency for many car drivers to try and 'beat' a heavy motor vehicle at intersections. The trainee should, if in doubt, give way to trucks even in situations where they might have the right of way.
6. Emphasise observation skills and anticipation of changing conditions.
7. Where possible have the candidate observe and comment on the movement of other vehicles through intersections and roundabouts.
8. The intersection blocking rule states that no vehicle may enter an intersection if the path through it, or exit from it, is blocked by stationary traffic. This includes the vehicle ahead. Trainees must not commit to an intersection if there is insufficient room for the vehicle to complete the manoeuvre.
9. Turning bays, flush medians and acceleration lanes all offer the opportunity for any vehicle to move safely out of or into traffic streams. They are not to be used for overtaking.
10. When turning into multiple lanes, drivers are required to turn into the lane closest to them. This applies both in urban and highway driving.  
Trainees should not move across into a left hand lane if turning right.
11. Care must be taken to ensure trainees do not receive misleading or improper signals from other road users. These might include failure to signal, incorrect signals, lane positions, driver clues etc. Explain these potential hazards.
12. Encourage correct approach speeds into intersections. The trainee must be able to stop safely, even if they have right of way.
13. When turning right on the open road, have the trainee signal left and pull over to the left if there is following and oncoming traffic. Once traffic has cleared, signal right and make the turn.

14.	When stationary at intersections, have the trainee hold the vehicle on the foot brake not the hand brake. Applying the foot brake will activate the brake lights and operate the brakes on all four wheels. The hand brake does not operate the brake lights and only applies the rear wheel brakes, insufficient in the event of rear-end collision.
15.	Make sure sufficient room is left between the trainee's vehicle and the one ahead when stopped at intersections. You should be able to see the rear wheels of the vehicle ahead. This also reduces the damage in the event of a rear-end collision.
16.	Reinforce steering control.
17.	Explain need for front wheels to be pointing straight ahead when stopped at intersections.
18.	Discuss consequences of excessive acceleration on dry and wet roads.
19.	Consider actions of cyclists and pedestrians and avoid kerb strikes.
20.	Anticipate green traffic lights changing to amber.
21.	Discourage overtaking in multiple laned roundabouts.
22.	Three-second signalling requirement not always possible in roundabouts. This should not prevent their use.

Faults	Symptom	Address/check
Lacking in confidence.	Approaches intersections too slowly. Stops when not required. Unnecessarily gives way.	Discuss. Use intersections with low traffic density for early lessons and progressively increase the degree of difficulty.
Excessive speed.	Approaches too fast.	System of vehicle control.
Fails to look both ways.	Fails to give way.	Observation / search techniques.
Proceeds before signal turns green.	Poor anticipation.	System of vehicle control.
Turns from incorrect position on road.	Illegal or unsafe turn.	System of vehicle control.
Proceeds on 'late' amber light.	Fails to stop when safe to do so.	System of vehicle control.
Fails to observe controls including traffic lights.	Enters intersection without stopping or giving way.	Check attitude and confidence.
Stops in wrong place to give way.	Stops too far back or, alternatively, in the opposing traffic stream.	Check that basic obligations are understood.
Fails to give way.	Vehicle with right of way is inconvenienced.	Basic obligations.
Fails to stop at a stop sign.	Disregards or fails to notice stop sign.	Check basic obligations are understood.

Not completely in correct lane.	Straddling lanes/too far right or left.	Discuss road positioning.
Uses wrong lane.	Fails to observe road marking arrows.	Observation skills. Discuss markings and lane use, particularly in roundabouts.
Poor use of lanes.	Turns into incorrect lane.	Basic obligations.

## 11 Cornering

11	Cornering
Trainee name	
Location	
Vehicle details	
<p>Given the high number of single vehicle crashes that occur in corners this lesson is an important component of the driver training programme. These loss of control incidents can occur at roundabouts and when turning, but are much more frequent, at higher speeds on the open road. Almost without exception, they occur as a result of driver error and a failure to react to the prevailing driving conditions. Of these the two key considerations must always be the 'vehicle' and the 'road'. This lesson focuses on open road cornering technique and line, particularly where a reduction in speed is required, and encourages the ongoing application of the system of vehicle control. This ensures that the same principles are applied when cornering or turning in town.</p>	
<p>References: Tranzqual ITO study guide US3465 Describe driving hazards and risk reduction strategies and responses to driving hazards and US3469 Apply control in driving a light motor vehicle.</p>	
Performance	Demonstrate correct cornering line and technique.
Standard	<p>Without inconveniencing other road users.</p> <p>While applying the system of vehicle control.</p> <p>While meeting all legal obligations.</p> <p>While maintaining vehicle control.</p>
Conditions	<p>In a light motor vehicle.</p> <p>On public roads.</p> <p>Through left and right hand corners.</p> <p>In daylight.</p> <p>In repeated trials.</p>
Revision	Performance objective 9: Hazards and the system of vehicle control.

Explain – demonstrate – practice

1. Learning points (general)		Comments	Date completed	DI initials
a.	Explains effects of speed, centrifugal force and vehicle centre of gravity on cornering stability.			
b.	Explains the purpose of corner advisory signs.			
c.	Explains the use of roadside markers to assist with cornering at night.			
d.	Explains the terms 'understeer' and 'oversteer'.			
e.	Explains the effects of loading on a vehicle during cornering.			
f.	Applies the system of vehicle control in all turning or cornering manoeuvres.			
2. Learning points (cornering technique)		Comments	Date completed	DI initials
a.	Explains the three points of a corner. (entry, apex and exit).			
b.	Identifies, interprets correctly and reacts to any advisory speed signs.			
c.	Completes all deceleration, braking and any downshifting before entering the corner.			
d.	Sets appropriate speed before entering corner.			
e.	Assesses severity of corner by reference to the search limit point at entry.			
f.	Maintains speed from the entry to the apex.			
g.	Accelerates gently from the apex to the exit.			

3. Learning points (cornering line – right hand bends)		Comments	Date completed	DI initials
a.	Adopts left hand lane position prior to entering corner.			
b.	Maintains speed and follows cornering line from left hand lane position at entry to right hand lane position at apex.			
c.	Accelerates gently from right hand lane position at the apex back to left hand lane position at the exit.			
d.	Maintains two handed steering control throughout the manoeuvre.			
4. Learning points (cornering line – left hand bends)		Comments	Date completed	DI initials
a.	Adopts right hand lane position prior to entering corner.			
b.	Maintains speed and follows cornering line from right hand lane position at entry to left hand lane position at apex.			
c.	Accelerates gently from left hand lane position at the apex back to right hand lane position at the exit.			
d.	Maintains two handed steering control throughout the manoeuvre.			

### Comments

### Instructor's notes

1.	Select corners for training that have advisory speed signs and, where possible, also include other corners that do not have these signs but require reductions in speed.
2.	The trainee should be able to explain the effects of centrifugal force, kinetic energy, friction and vehicle centre of gravity.
3.	Minimal, if any, downshifting (manual) should be required in highway cornering unless the recommended cornering speed is extremely low.
4.	Emphasise the advantages of the system of vehicle control in all cornering.

5.	Discuss the effects of loads on vehicle handling including load placement, the effects of load shift and towing a trailer.	
6.	Discuss intersections and roundabouts and the need to control vehicle speed especially in roundabouts. Explain the risks associated with road camber (positive and negative).	
7.	Explain highway speed advisory signs and the information presented on them.	
8.	Discuss the importance of making the final corner assessment by reference to the search limit point on approach to the entry. This means that, as the vehicle approaches the entry to the corner, the driver looks as far into the corner as he can and bases his cornering speed on this. This, obviously, is critical when advisory speed signs are not available.	
9.	Leaving the designated lane is not an option during cornering. This means that, at no time, should the vehicle cross the centre line or, particularly on blind corners, the left hand 'fog' line.	
10.	Emphasise that no two corners the same. Corner radii might be the same but road surface and condition, lane width and camber all differ. Each must be approached with caution.	
11.	Explain 'understeer' and 'oversteer' and provide examples of what might cause these. Include the effects of reduced traction on low friction surfaces and how to correct the problem if it occurs.	
12.	Emphasise the need for correct two handed steering technique.	
13.	Emphasise need to complete all braking in a straight line NOT in the corner. This, and excessive acceleration, are the key causes of 'oversteer' and 'understeer'.	
14.	Discuss dangers on narrow rural roads of speed and position of oncoming traffic, farm gateways on or near corners etc.	
Faults	Symptom	Address/check
Fails to observe speed advisory signs.	Excessive speed during cornering. Late braking or downshifting.	System of vehicle control/observation techniques.
Poor cornering technique.	Braking or over acceleration in corners.	System of vehicle control/observation technique.
Poor cornering line.	Crosses centre line/fog line.	Steering technique/lane position.
Poor steering control.	One handed steering. Oversteer. Hand position.	Steering technique.

## 12 Moving off – uphill and downhill

12	Moving off – uphill and downhill
Trainee name	
Location	
Vehicle details	
<p>While this lesson is a natural progression from lesson 5 Moving off and stopping- at an angle, and can be incorporated with that lesson where appropriate, there is a higher level of competency required to <u>move off up a grade. This performance objective relates to vehicles with manual transmissions although relevant assessment points can be used for those driving cars fitted with automatic transmissions.</u></p>	
<p>References: Tranzqual ITO study guide US3469 Apply control in driving a light motor vehicle.</p>	
Performance	<p>Move off on an uphill grade.</p> <p>Move off on a downhill grade.</p>
Standard	<p>Without inconveniencing other road users.</p> <p>While meeting all legal obligations.</p> <p>While maintaining vehicle control.</p> <p>Without excessive clutch slip or over revving the engine.</p> <p>Without stalling.</p> <p>Without rolling backwards/forwards.</p>
Conditions	<p>In a light motor vehicle</p> <p>On public roads.</p> <p>On uphill and downhill grades.</p> <p>In daylight.</p> <p>In repeated trials.</p>
Revision	Performance objective 5: Moving off and stopping – at an angle

Explain – demonstrate – practice

1. Learning points (moving off – uphill)		Comments	Date completed	DI initials
a.	Signals intention to move.			
b.	Uses mirrors to check behind.			
c.	Selects first gear.			
d.	Applies extra rpm while slowly releasing the clutch.			
e.	Holds the vehicle on the hand brake until the clutch starts to take up.			
f.	Checks mirrors again and checks over shoulder.			
g.	Releases the hand brake.			
h.	Releases the clutch and applies gentle power.			
i.	Does not roll back.			
j.	Does not stall the vehicle.			
k.	Steers right onto the road.			
l.	Accelerates as necessary and cancels signal.			
m.	Moves off without inconveniencing other road users.			

2. Learning points (moving off – downhill)		Comments	Date completed	DI initials
a.	Signals intention to move.			
b.	Uses mirrors to check behind.			
c.	Selects first or second gear. (dependent on grade) and keeps clutch depressed.			
d.	Holds on footbrake and releases hand brake.			
e.	Checks mirrors again and checks over shoulder.			
f.	Releases clutch pedal and footbrake together.			
g.	Steers right onto the road.			
h..	Accelerates as necessary and cancels signal.			
i.	Moves off without inconveniencing other road users.			

Comments

### Instructor's notes

1. This lesson is a continuation of lesson 5. Initial practice should be deliberate and focused until confidence and ability improves.
2. If using an automatic car, simply assess relevant points and, if appropriate, add others in the spaces provided. This manoeuvre in an automatic is very straight forward.
3. Explain reason for extra power and encourage trainees to listen for the change in engine noise as the clutch starts to take up.
4. Explain that the left foot should cover the clutch pedal until the vehicle is underway. In this way the likelihood of stalling the vehicle is minimised.

5.	Consider practicing the uphill sequence on flat ground first if this helps.	
6.	Explain the action to be taken if the car does stall. Apply the hand brake so the vehicle cannot roll back when the clutch is depressed. Start again.	
7.	Explain the importance of the foot brake when moving off downhill. Hand brake is not required when moving off.	
8.	When teaching moving off – down hill, follow the basic sequence of Lesson 5 but consider the effects of vehicle mass and encourage the trainee to start off in a higher gear and let the slope start the vehicle moving. This saves unnecessary gear shifting.	
Faults	Symptom	Address/check
Races engine when moving off uphill.	Excessive engine speed, vibration, slipping clutch.	Practice. Coordination.
Fails to depress clutch pedal fully.	Gear clashing.	Confidence/practice. Coordination.
Poor clutch, accelerator and hand brake co-ordination when moving off uphill.	Vehicle moves off in jerks, stalls or rolls back.	Practice. Coordination.
Inconveniences other road users.	Fails to indicate, fails to check mirrors, complete shoulder check.	Practice sequence.

## 13 Negotiating steep grades

13 Negotiating steep grades	
Trainee name	
Location	
Vehicle details	
<p>It is a simple dynamic fact that, as a result of gravity, hills will adversely affect the performance of a vehicle unless the driver anticipates the climb or descent and manages the transmission and brakes. There are often additional potential hazards present on steep hills and crashes due to poor decision making are not uncommon. The correct hill driving techniques are very simple but the trainees must understand the limitations of their own vehicle, and other road users, especially trucks, and appreciate the possible consequences of getting it wrong, not only to themselves but also to other motorists.</p>	
References: N/A	
Performance	<p>Negotiate a steep ascent.</p> <p>Negotiate a steep descent.</p>
Standard	<p>Without inconveniencing other road users.</p> <p>While meeting all legal obligations.</p> <p>While maintaining vehicle control.</p> <p>Without stopping the vehicle.</p> <p>While applying correct gear selection.</p> <p>Without excessive braking.</p>
Conditions	<p>In a light motor vehicle.</p> <p>On public roads.</p> <p>On steep uphill and downhill grades.</p> <p>In daylight.</p> <p>In repeated trials.</p>
Revision	Performance objective 9: Hazards and the system of vehicle control and 12 Moving off uphill and downhill.

Explain – demonstrate – practice

1. Learning points (general)		Comments	Date completed	DI initials
a.	Identifies, explains and reacts correctly to road signs that indicate steep gradients.			
b.	Explains and, if necessary, uses slow vehicle bays and passing lanes on hills.			
c.	Demonstrates a patient response to slower vehicles on grades.			
d.	Checks following traffic on approach to grades.			
2. Learning points (steep ascents)		Comments	Date completed	DI initials
a.	As road speed drops, selects a lower gear to maintain road speed (manual).			
b.	Uses the tachometer (if fitted) effectively to monitor engine speed.			
c.	Maintains correct following distances behind slower vehicles.			
d.	Makes use of available lanes to minimise interference to following traffic.			
e.	Overtakes (where appropriate) safely.			
f.	Maintains correct lane position.			
g.	Displays courtesy to other road users.			
3. Learning points (steep descents)		Comments	Date completed	DI initials
a.	Selects suitable gear (manual and automatic) to reflect road conditions and maximise engine braking effect.			

b.	Uses brakes to control engine rpm and/or road speed.
c.	Monitors tachometer (where fitted) to manage engine speed.
d.	Brakes to reduce road speed before making any additional down shifts on the gradient.
e.	Uses slow vehicle bays or lanes to allow faster traffic past.
f.	Maintains correct lane position
g.	Displays courtesy to other road users.

### Comments

### Instructor's notes

1.	Explain gradient road signs and reactions to these.
2.	Explain the effects of gradients on other traffic, especially heavy motor vehicles and vehicles towing loaded trailers and consequences for the drivers of these if they get it wrong.
3.	Ensure the trainee understands the various shift options available in their vehicle whether manual or automatic. The use of the tachometer in terms of monitoring engine speed should be explained.
4.	Ensure the trainee understands how to recognise a labouring engine on an uphill gradient and how a lower gear will rectify this situation.
5.	Have the trainee experiment with descending grades in different gears to appreciate the effectiveness of the engine compression and the ability of the various gear options to control descent speed.
6.	Explain the causes and consequences of over-heated brakes.
7.	Loss of control relates, in particular, to a vehicle in neutral and rapidly picking up speed or one that has suffered serious brake fade. In these situations use everything available including park brakes and look for an 'out'. These might include running into a drain, along a bank or through a fence into a paddock. Anything that keeps the vehicle on the correct side of the road and brings it to a stop will suffice. Remember, however, that the situation will not arise if the correct driving techniques are applied.
8.	When climbing hills behind heavy vehicles, ensure following distances are being maintained. If the truck ahead misses a gear, for example, the driver should be able to avoid the problem without stopping, and trucks do miss gears!
9.	There is no 'correct' gear for descending a hill. The question that must be asked is 'Was it done safely?' One driver might select one gear higher than another driver and use a little more brake. A third driver might select one gear lower and use less brake but take just a little longer to make the descent. All three drivers would probably be doing just fine. As the instructor you must keep this point in mind.

10.	Discuss with the trainee the use of slow vehicle bays. During descents drivers, irrespective of vehicle type or size, should use slow vehicle bays if they are holding up following traffic and adjust speed to let all traffic past. Don't allow trainees to 'hang' left when descending hills but stay within the lane until a suitable turn out area has been reached.
11.	Discuss dangers of overtaking slower vehicles on grades, including 100m visibility, speed of oncoming traffic relative to speed of vehicle being overtaken.

Faults	Symptom	Address/check
Doesn't down shift soon enough on ascents.	Engine begins to labour.	Use skip/block shifting to regain engine speed and drive.
Changes to incorrect gear (too high) on ascents.	Immediate loss of engine speed.	As above.
Follows heavy vehicle ahead too closely.	Inadequate following distance. Build up of traffic behind.	Back off in case vehicle ahead stops suddenly.
Incorrect gear (too low) for ascent.	Engine over-revving.	Back off the accelerator or change up a gear.
Uses incorrect lane during climbs.	Faster traffic passing on left.	Indicate, move into left hand lane.
Fails to monitor tachometer.	Over-revving.	Revisit key tachometer.
Wrong gear selection for down hill grade.	Vehicle speed too high or excessively slow.	Identify early, slow down and select appropriate gear.
Excessive brake use or rides the brake.	Vehicle speed high, brake smell.	Check tachometer, slow vehicle and select lower gear.
Fails to check mirrors frequently or disregards slow vehicle bays.	Build up of following traffic.	Revisit observation techniques Use slow vehicle bays to clear following traffic
Fails to hold correct lane position.	Crosses centre line in corners.	Revisit basic obligations.
Fails to anticipate relative speeds of vehicles when overtaking.	100m not achieved.	Revisit basic obligations and discuss risks associated with overtaking on hills.

## 14 Overtaking and use of passing lanes

14	Overtaking and use of passing lanes
Trainee name	
Location	
Vehicle details	
<p>While overtaking is an option for every driver who encounters slower traffic, it is a manoeuvre that should only be considered if there is a considerable amount of clear road, 300–400m, for the manoeuvre to be carried out safely. While the number of passing lanes continues to grow around the country, trainees should be encouraged to overtake where these are not available but only when it is safe to do so. While overtaking represents probably the most dangerous manoeuvre a driver can carry out, if done properly the risks can be managed and progress maintained. Slower vehicles are a fact of life on New Zealand roads and trainees should not be discouraged from carrying out what is a fairly standard driving manoeuvre. Both the legal requirements and the recommended sequence for overtaking must be dealt with by instructors so that trainees quickly develop confidence and an ability to safely undertake overtaking manoeuvres.</p> <p>The use of passing lanes must also be managed by drivers so that they don't interfere with the opportunity for faster following traffic to overtake. Driver responses to these road features often lead to frustration and, as a consequence, serious mishaps.</p>	
<p>References: ITO study guide US 3465 Describe driving hazards and risk reduction strategies and responses to driving hazards and US 3466 Apply risk reduction techniques and strategies while driving.</p>	
Performance	<p>Safely overtake a slower vehicle.</p> <p>Make efficient and courteous use of passing lanes.</p>
Standard	<p>Without inconveniencing other road users.</p> <p>While meeting all legal obligations.</p> <p>While maintaining vehicle control.</p> <p>Using the system of vehicle control.</p>
Conditions	<p>In a light motor vehicle.</p> <p>On public roads.</p> <p>In daylight.</p> <p>In repeated trials.</p>
Revision	Performance objective 9: Hazards and the system of vehicle control

Explain- demonstrate - practice

1. Learning points (general)		Comments	Date completed	DI initials
a.	Explains places where overtaking is prohibited.			
b.	Applies the 12-second search pattern.			
c.	Explains risks associated with overtaking.			
d.	Applies the system of vehicle control.			
e.	Displays a courteous approach to overtaking, passing and being passed.			
f.	If in doubt, stays back.			
2. Learning points (overtaking)		Comments	Date completed	DI initials
a.	Maintains correct following distances.			
b.	Checks ahead for sufficient clear road (including any side roads or driveways where other vehicles may enter from).			
c.	Checks behind in mirrors and blind spots for other overtaking traffic.			
d.	Signals right for at least 3 seconds.			
e.	Checks mirrors again and moves to the right to overtake.			
f.	Accelerates to overtaking speed but not in excess of speed limit.			

g.	Taps horn or flashes light if this is deemed necessary (eg situations such as vehicle overtaken appears unstable or driver is inattentive).			
h.	Signals left for at least 3 seconds.			
i.	Checks near side mirrors for clearance.			
j.	Moves left back into the correct lane position.			
k.	Cancels signal and resumes speed.			
l.	Has 100m clear road throughout the whole overtaking manoeuvre.			
<b>3. Learning points (passing lanes)</b>		<b>Comments</b>	<b>Date completed</b>	<b>DI initials</b>
a.	Identifies warning signs in advance.			
b.	Signals intention to move into left hand lane or slow vehicle bay.			
c.	Moves into left hand passing lane (or slow vehicle bay).			
d.	Delays own overtaking manoeuvre if this will hinder ability of faster following traffic to overtake.			
e.	Adjusts speed to allow all faster traffic past.			
f.	Indicates, at least 3 seconds, intention to merge at end of lane.			
g.	Checks mirrors and completes shoulder check before merging.			
h.	In general driving does not attempt to move left for following traffic in situations where vehicle safety may be compromised or overtaking vehicles are still forced to cross the centre line.			
Comments				

## Instructor's notes

1. This lesson should cover both overtaking in passing lanes and the correct use of slow vehicle bays (where available). Depending on traffic conditions it might not be possible to teach or assess overtaking on a highway. The overtaking procedures for this are mirrored in the sequence for overtaking in passing lanes and this might be the more sensible approach to the lesson.
2. While the road centre line will lead traffic into the left hand lane in passing lanes, encourage the use of the left hand indicator as this will often cause tail-gating drivers to realise there is a passing lane ahead and delay any ill considered overtaking to get into the right hand lane.
3. Indicating the intention to merge at the end of passing lanes should not occur immediately prior to moving right. Encourage the use of indicators halfway between the advance warning sign and the actual merge point sign. This will allow following drivers a little extra time to decide whether to overtake or stay back. Drivers should, however, anticipate the last second 'mad dash' to get past the slower vehicle and adjust speed, where possible, to let them past.
4. Places where overtaking is prohibited include the following: in advance of corners or the crests of hills, through some intersections, where insufficient room exists for overtaking, through right turn bays, over flush medians, over a solid yellow line, within 60m of a railway crossing, pedestrian crossings.
5. Overtaking includes not only moving around other slower vehicles but also any other objects or situations that require the driver to cross the road centre line or change lanes for any reason. These might include cyclists, pedestrians, animals, objects lying on the road, road irregularities (potholes etc) and moving past parked vehicles.
6. Emphasise that indicators are the only means of communication between drivers. Use them early and consistently in all traffic conditions.
7. Slow vehicle bays or lanes are not 'passing lanes' in the normal sense. Slower vehicles (and this includes cars) need only use these when there is traffic being held up behind. In passing lanes drivers are obliged to use the left hand lane unless overtaking.
8. Assess the trainee's ability to judge speed, time and distance. They are the key to so many driving situations, not least of which is overtaking.
9. Emphasise the dangers of blind spots and the need to conduct shoulder checks before overtaking or merging.
10. The system of vehicle control forms the basis of any overtaking manoeuvre and this can be used as the basis for teaching.
11. Emphasise the old adage 'If in doubt, don't overtake!'
12. Determine if trainees can estimate the speed of other vehicles and choose appropriate times and places to overtake.
13. Identify trainees' confidence in their ability to overtake, noting whether they hesitate and then speed up, and whether they make the overtaking manoeuvre in one continuous manoeuvre.
14. As skill and the judgment of speed and distance develop over confidence may occur. Encourage patience and always leave a margin of safety for error.

Faults	Symptom	Address/check
Not using mirrors or checking blind spots.	Fails to check for other traffic.	System of vehicle control. Frequency of mirror checks 5–10 secs.
Overtaking into oncoming traffic.	Commencing overtaking manoeuvre with inadequate clear road.	System of vehicle control. Speed, time and distance.
Cuts in front of overtaken vehicle.	Flashing lights, horn sounded or braking by vehicle overtaken. Oncoming vehicle.	System of vehicle control. Use of mirrors. Time and distance.
Insufficient clearance.	Runs too close to vehicle being overtaken.	Observation skills, steering technique, spatial awareness.
Illegal overtaking.	Overtakes in the wrong place in breach of traffic law.	Revisit knowledge of traffic law.
Fails to move left for following traffic.	Build up of traffic behind the vehicle in situations where opportunity existed to let vehicles past.	Use of mirrors. Attitude.
Fails to indicate early.	Indicators used at last moment before changing direction.	Use of indicators and defensive driving.
Fails to adjust speed when being overtaken.	Last moment 'near hits' from faster vehicles. Reactions of other drivers. Speeds up in passing lanes.	Speed management in any 'being overtaken' situation.
Does not move away from vehicle that has been overtaken.	Now holds up the vehicle overtaken.	Confidence, use of mirrors.

## 15 Town driving

15	Town driving
Trainee name	
Location	
Vehicle details	
<p>While highway driving occupies a large part of a some drivers' time, the majority of drivers spend most of their time driving in towns or cities. Restricted manoeuvrability, high traffic volumes and a much wider range of potential hazards present a real challenge for drivers, especially new ones, and to manage these requires patience, skill and knowledge. All drivers share basic obligations in this environment and a responsible and courteous attitude must be applied. Trainees need to quickly develop the ability to anticipate and predict the movements of other road users and to apply the hazard action plan and the system of vehicle control. This lesson has been broken into segments that reflect the six driving conditions.</p>	
<p>References: ITO study guide US 3465 Describe driving hazards and risk reduction strategies and responses to driving hazards and US3466 Apply risk reduction techniques and strategies while driving.</p>	
Performance	Drive safely and efficiently in town.
Standard	<p>Without inconveniencing other road users.</p> <p>While meeting all legal obligations.</p> <p>While maintaining vehicle control.</p> <p>Using the system of vehicle control.</p> <p>Applying the hazard action plan.</p>
Conditions	<p>In a light motor vehicle.</p> <p>On public roads in town in 50–70km/h speed zones.</p> <p>In daylight.</p>
Revision	Performance objective 9: Hazards and the system of vehicle control

## Explain- demonstrate - practice

1. Learning points (general)		Comments	Date completed	DI initials
a.	Identifies potential hazards, predicts developments, decides on a course of action and acts on that decision.			
b.	Applies the system of vehicle control in all hazard avoidance situations.			
c.	Signals in advance of all turns or changes in direction.			
2. Learning points (road conditions)		Comments	Date completed	DI initials
a.	Maintains correct lane position.			
b.	Applies the system of vehicle control at intersections and obeys all controls.			
c.	Observes and reacts to all road signs and markings.			
d.	Reacts to railway crossings in the correct manner.			
e.	Reacts to pedestrian crossings in the correct manner.			
f.	Applies a cautious, courteous and patient driving style around busy shopping areas and schools.			

3. Learning points (traffic conditions)		Comments	Date completed	DI initials
a.	Applies 2-second rule.			
b.	Applies appropriate scanning techniques around the vehicle (to the sides, behind, 12-second search ahead and where appropriate shoulder checks).			
c.	Stays left in multiple lanes unless setting up to turn right or passing slower traffic.			
d.	Identifies and anticipates actions of turning, oncoming traffic.			
e.	Monitors parked vehicles and adjusts lane position around parked vehicles.			
f.	Monitors and anticipates the movement of pedestrians.			
g.	Identifies and reacts to avoid any animal on the road.			
h.	Identifies and, where appropriate, gives way to service vehicles.			
i.	Monitors and anticipates the movement of cyclists.			
4. Learning points (vehicle conditions)		Comments	Date completed	DI initials
a.	Vehicle meets warrant of fitness standard.			
b.	Driving performance reflects an appreciation of the power and transmission options of the vehicle.			
c.	Manoeuvres the vehicle safely with consideration to size.			
d.	Secures and distributes any load to meet legal and stability parameters.			

e.	Vehicle speed reflects the driving conditions and posted speed limits.			
f.	Maintains correct road position in all driving situations.			
<b>5. Learning points (weather conditions)</b>		<b>Comments</b>	<b>Date completed</b>	<b>DI initials</b>
a.	Driving performance reflects the prevailing weather conditions.			
<b>6. Learning points (light conditions)</b>		<b>Comments</b>	<b>Date completed</b>	<b>DI initials</b>
a.	Takes steps to minimise the effects of any sun strike or glare.			
b.	Uses vehicle headlights in any low light conditions.			
<b>7. Learning points (driver conditions)</b>		<b>Comments</b>	<b>Date completed</b>	<b>DI initials</b>
a.	Displays a courteous and patient driving style.			
b.	Displays effective observation and manipulative skills.			

Comments

<b>Instructor's notes</b>	
1.	Consider doing commentary drives as part of your demonstration and, if the trainee is capable, have them do the same once the teaching phase has been completed. This tool remains the only reliable method of assessing driver observation and anticipation skills.
2.	Encourage an unrushed driving style and the benefits of applying correct lane positions and following distances.
3.	The system of vehicle control, yet again, provides a systematic approach to driving that is crucial in these conditions.

4.	This session offers the opportunity to assess progress relating to a large number of the early lessons and the trainee should, by now, be consistently competent in the basic driving skills.	
5.	Excessive downshifting in a car fitted with a manual transmission, prior to stopping, should be discouraged. It adds unnecessary, and distracting, activity and is pointless in many situations. Downshifting into third gear should be all that is necessary.	
6.	Bright and low light conditions demand, for obvious reasons, different reactions by the driver. If the risk of sun strike exists the windscreen must be kept clean and sun visors and sunglasses used. In low light conditions, even in the middle of the day, consider the colour of the vehicle and encourage the trainee to switch on headlights to improve conspicuity.	
7.	Keep in mind that this driving environment contains more potential hazards and risks than any other. Effective observation skills become paramount and the development of the ability to anticipate and predict the movement of other road users has to be encouraged and targeted as a priority. Assess progress of this aspect of driving by applying the hazard action plan.	
8.	Initial lessons should be planned for quiet periods during the day and then 'ramped up' as confidence improves. Any final assessments should be conducted in medium to heavy traffic conditions.	
Faults	Symptom	Address/check
Fails to keep left.	Vehicle straddles lanes or stays in right hand lane.	Use of lanes.
Unreasonably slow.	Interference to other traffic. Well below speed limit.	Confidence. Is this lesson too soon?
Erratic speed.	Unnecessary changes in speed.	Confidence. Spatial awareness.
Unaware of surrounding traffic.	Not using mirrors.	System of vehicle control.
Too fast.	Exceeds speed limit.	Legal obligations. Overconfidence.
Follows too closely.	Too close to vehicle ahead.	2-second rule.
Too fast at railway or pedestrian crossings.	Fails to react to crossings in correct manner.	Observation, system of vehicle control, legal obligations.
Fails to obey controls.	Not stopping at stop signs or red traffic lights. Not applying give way rule.	System of vehicle control, observation, attitude.
Poor observation skills.	Late reactions to hazards, failure to check mirrors, erratic steering.	Observation, hazard action plan, system of vehicle control.
Impatience.	Vocal or physical responses to road users, following too close, excessive speed, poor signalling.	Time out. Legal obligations, attitude.

## 16 Motorway driving

16	Motorway driving
Trainee name	
Location	
Vehicle details	
<p>While, by world standards, New Zealand has a very limited number of motorways and expressways, and almost all of these servicing the main centres, they attract extremely high traffic volumes and present their own potential risks. There are also a large number of dual carriageways that present similar problems and much of what follows can be related to both of these busy driving environments.</p>	
<p>References: ITO study guide US 3465 Describe driving hazards and risk reduction strategies and responses to driving hazards and US3466 Apply risk reduction techniques and strategies while driving.</p>	
Performance	Enter, leave and drive safely and efficiently on a motorway.
Standard	<p>Without inconveniencing other road users.</p> <p>While meeting all legal obligations.</p> <p>While maintaining vehicle control.</p> <p>Using the system of vehicle control.</p> <p>Applying the hazard action plan.</p>
Conditions	<p>In a light motor vehicle</p> <p>On a motorway or expressway.</p> <p>In daylight.</p>
Revision	Performance objective 9: Hazards and the system of vehicle control

## Explain- demonstrate - practice

1. Learning points (general)		Comments	Date completed	DI initials
a.	Explains the basic rules of motorway driving.			
b.	Identifies potential hazards, predicts developments, decides on a course of action and acts on that decision.			
c.	Applies the system of vehicle control in all hazard avoidance situations.			
2. Learning points (road conditions)		Comments	Date completed	DI initials
a.	Adopts, and maintains, correct lane position.			
b.	Checks mirrors and blind spots and indicates for at least 3 seconds prior to any lane change.			
c.	Observes all road markings and reacts early to all motorway signs.			
d.	Accelerates to motorway speed (when travelling in merge lane), checks mirrors and blind spots, indicates for at least 3 seconds and selects appropriate gap before merging with other traffic on the motorway.			
e.	Identifies exit, adjusts lane position early, indicates intention to leave the motorway for at least 3 seconds and exits safely.			
3. Learning points (traffic conditions)		Comments	Date completed	DI initials
a.	Applies 2 second rule.			
b.	Overtakes slower traffic in the same lane safely and in accordance with traffic law.			
c.	Apply appropriate scanning techniques around the vehicle (to the sides, behind, 12 second search ahead			

	and where appropriate shoulder checks).			
d.	Stays left in multiple lanes.			
e.	Avoids unnecessary lane changes.			
f.	Identifies and, where necessary, adjusts speed for traffic joining the motorway.			
g.	Identifies and, where necessary, adjusts speed for traffic leaving the motorway.			
h.	Gap selection appropriate in all manoeuvres.			
<b>4. Learning points (vehicle conditions)</b>		<b>Comments</b>	<b>Date completed</b>	<b>DI initials</b>
a.	Vehicle meets warrant of fitness standard.			
b.	Driving performance reflects an appreciation of the power and transmission options of the vehicle.			
c.	Vehicle speed reflects the driving conditions and posted speed limits.			
d.	Maintains appropriate road position in all driving situations.			
<b>5. Learning points (weather conditions)</b>		<b>Comments</b>	<b>Date completed</b>	<b>DI initials</b>
a.	Driving performance reflects the prevailing weather conditions.			
<b>6. Learning conditions (light conditions)</b>		<b>Comments</b>	<b>Date completed</b>	<b>DI initials</b>
a.	Takes steps to minimise the effects of any sun strike or glare.			
b.	Uses vehicle headlights in any low light conditions.			

7. Learning points (driver conditions)		Comments	Date completed	DI initials
a.	Displays a courteous and patient driving style.			
b.	Displays effective observation and manipulative skills.			

Comments

Instructors notes	
1.	For the purpose of this lesson, the driving environment must include on ramps and off ramps. Motorways and expressways will both provide these features.
2.	Encourage an unrushed driving style and the benefits of applying correct following distances. While most drivers, at least initially, will disagree with the ability to maintain correct following distances in heavy motorway traffic, this is, in fact, a fallacy. Even in peak traffic, the 2 second rule can be applied quite successfully.
3.	The system of vehicle control, yet again, provides a systematic approach to driving that is crucial in these conditions.
4.	While most of our motorway systems are dual carriageways, there are those that have three, and sometimes more, lanes. While keeping left is the basic rule on these roads it is acceptable for drivers to adopt, and maintain, a centre lane position so that repeated lane changes (as a result of traffic joining and leaving the motorway), and their inherent risks, are avoided. Vehicle speed, however, should not be such that it is causing interference for faster traffic. If this occurs use the left hand lane. On dual carriageways always use the left hand lane unless moving around slower traffic or adjusting lane position for joining traffic.
5.	Unnecessary lane changes increase driving risk and the habit, of many drivers, to consistently change lanes in medium to heavy traffic in the belief that they will get to where they are going much quicker is simply not acceptable. Emphasise the risks associated with blind spots and unnecessary lane changes.
6.	Common hazards include faster traffic, slow traffic, traffic not indicating, late lane changes particularly to exit the motorway, tailgating traffic, vehicles changing lanes.
7.	Bright and low light conditions demand, for obvious reasons, different reactions by the driver. If the risk of sun strike exists the windscreen must be kept clean and sun visors and sunglasses used. In low light conditions, even in the middle of the day, consider the colour of the vehicle and encourage the trainee to switch on headlights to improve conspicuity.
8.	Keep in mind that this driving environment demands effective observation skills and the development of the ability to anticipate and predict the movement of other road users has to be encouraged and targeted as a priority.

9.	<u>Emphasise that the key ingredients for safe motorway driving in any vehicle are the maintenance of an appropriate lane position, correct following distances, signalling and early responses to all planned moves.</u>
10.	Teach trainees to expect frustrations on our motorways and accept that many other drivers are not as competent, as they are.
11.	The way in which other vehicles are driven on the motorway should not influence the trainee. The fact is that many drivers do not drive competently.
12.	Emphasise the correct use of on and off ramps in terms of acceleration, gap selection, signalling and use of mirrors and head checks.
13.	Discuss effects of cross winds, spray, especially from large vehicles, risks of aquaplaning at high road speeds etc.
14.	Discuss actions in the event of a break down on a motorway.
15.	Discuss effects of monotony, boredom and fatigue in relation to motorway driving, especially at the end of a long journey.

Faults	Symptom	Address/check
Fails to keep left.	Stays in right hand lane.	Use of lanes.
Unreasonably slow.	Interference to other traffic. Well below speed limit.	Confidence. Is this lesson too soon?
Improper use of acceleration or exit lane.	Doesn't adjust speed to traffic flow. Too slow or too fast.	System of vehicle control. Overconfident or lacking confidence?
Fails to indicate intentions.	Reactions of other drivers. Inconveniences traffic.	Legal obligations.
Too fast.	Exceeds speed limit.	Legal obligations. Overconfidence.
Follows too closely.	Too close to vehicle ahead.	2-second rule.
Fails to frequently check mirrors.	Unaware of movement of other traffic.	Confidence? Check every 5–10 seconds.
Fails to observe signs.	Misses, or late response to, exit. Exits from incorrect lane	Observation. Nervousness. Lesson too soon?
Fails to maintain constant lane position.	Unnecessary lane changes.	Over confidence. Correct lane use. Risk assessment.
Not completely in correct lane.	Straddles lane markings.	Spatial awareness. Vehicle references.

## 17 Rural/open road driving

17	Rural/open road driving
Trainee name	
Location	
Vehicle details	
<p>New Zealand offers one of the best driver training environments in the world. We have more corners and hills per thousand kilometres than most other developed countries and our weather and road conditions offer challenges that would test any driver.</p> <p>Unfortunately, these same conditions play a large part in far too many serious road crashes, often due to driver error. It is in these challenging conditions that many drivers spend only a very small amount of their total driving time and where they must take particular care given that many of the hazards are unique to that environment. This lesson covers the system of vehicle control and the six driving conditions and the potential hazards that might exist on our highways. This is an advanced lesson that brings together many of the points covered in earlier sessions. Instructors should use the appropriate columns to reflect sealed or unsealed road conditions.</p>	
<p>References: Tranzqual ITO study guides US 3465 Describe driving hazards and risk reduction strategies and responses to driving hazards and US3466 Apply risk reduction techniques and strategies while driving and US 17678 Drive a light motor vehicle on unsealed roads.</p>	
Performance	Drive safely and efficiently on a rural road.
Standard	<p>Without inconveniencing other road users.</p> <p>While meeting all legal obligations.</p> <p>While maintaining vehicle control.</p> <p>Using the system of vehicle control.</p> <p>Applying the hazard action plan.</p>
Conditions	<p>In a light motor vehicle.</p> <p>On sealed and/or unsealed rural roads.</p> <p>In daylight.</p>
Revision	Performance objective 9: Hazards and the system of vehicle control

## Explain - demonstrate - practice

1. Learning points (general)		Comments: sealed	Comments: unsealed	Date completed	DI initials
a.	Identifies potential hazards, predicts developments, decides on a course of action and acts on that decision.				
b.	Applies the system of vehicle control in all hazard avoidance situations.				
c.	Anticipates driving conditions and adjusts driving behaviours to the conditions.				
d.	Abides by all permanent and temporary speed signs.				
2. Learning points (road conditions)		Comments: sealed	Comments: unsealed	Date completed	DI initials
a.	Adopts, and maintains, appropriate lane or road position.				
b.	Checks mirrors and blind spots and indicates for at least 3 seconds prior to any change in direction that causes the vehicle to cross the road centre line.				
c.	Observes all road markings and reacts early to all warning and advisory signs.				
d.	Ascends and descends hills in an appropriate gear.				
e.	Negotiates corners in accordance with advisory speed signs, applying the correct cornering line and technique.				
f.	Where appropriate, slows for narrow or one lane bridges and obeys any right of way signs.				
g.	Positions vehicle to avoid contact with bridge structure or any oncoming vehicles.				
h.	Adopts correct turning positions.				
i.	Observes all controls or applies the Give Way rule correctly.				

j.	Indicates intention to turn at least 3 seconds in advance.				
k.	Reacts early to permanent and temporary warning signs.				
l.	Observes and complies with any changes to the speed limit including any temporary speed limits and obeys all controls.				
m.	Identifies unsealed roads by sign or road discolouration.				
n.	Reduces speed on unsealed roads.				
o.	Uses left lane in passing lanes unless overtaking.				
p.	Where necessary, adjusts speed to allow faster traffic past.				
q.	Uses indicators effectively.				
<b>3. Learning points (traffic conditions)</b>		<b>Comments: sealed</b>	<b>Comments: unsealed</b>	<b>Date completed</b>	<b>DI initials</b>
a.	Monitors traffic conditions.				
b.	Applies 2-second rule.				
c.	Applies appropriate scanning techniques around the vehicle (to the sides, behind, 12-second search ahead, and where appropriate shoulder checks).				
c.	Overtakes in accordance with legal requirements.				
d.	Overtakes safely.				
e.	Maintains correct lane position and speed.				
f.	Monitors overtaking traffic.				

g.	Where necessary reduces speed and applies correct overtaking procedures in response to cyclists and pedestrians.				
h.	Adjusts speed to avoid passing oncoming vehicles and cyclists / pedestrians at the same time.				
i.	Reacts to any signs that might indicate stock on the road.				
j.	If stock is encountered, slows down or covers brake and, if necessary, prepares to stop.				
k.	Observes any requests or directions from drovers.				
l.	Applies cautious approach to slow farm machinery.				
m.	Anticipates abrupt, or late, overtaking manoeuvres from other vehicles when encountering oncoming farm vehicles or machinery.				
n.	Does not exceed 20 kmph when passing a stationary school bus (from either direction).				
<b>4. Learning points (vehicle conditions)</b>		<b>Comments: sealed</b>	<b>Comments: unsealed</b>	<b>Date completed</b>	<b>DI initials</b>
a.	Vehicle meets warrant of fitness standard.				
b.	Driving performance reflects an appreciation of the power and gear selection options of the vehicle.				
c.	Vehicle speed reflects the driving conditions.				
d.	Maintains appropriate road position in all driving situations.				
<b>5. Learning points (weather conditions)</b>		<b>Comments: sealed</b>	<b>Comments: unsealed</b>	<b>Date completed</b>	<b>DI initials</b>
a.	Driving performance reflects the prevailing weather conditions.				

6. Learning points (light conditions)		Comments: sealed	Comments: unsealed	Date completed	DI initials
a.	Takes steps to minimise the effects of any sun strike or glare.				
b.	Uses vehicle headlights in any low light conditions.				
7. Learning points (driver conditions)		Comments: sealed	Comments: unsealed	Date completed	DI initials
a.	Displays a courteous driving style.				
b.	Displays an unrushed, patient driving style.				
c.	Applies knowledge and skills to produce a competent driving standard.				
d.	Explains simple steps to avoid driver fatigue.				
e.	Avoids internal and external distractions that might affect vehicle control and observation technique.				
f.	Maintains two handed steering unless operating other controls.				

Comments

Instructors notes	
1.	It is unlikely that this lesson will be achieved in one session. Instructors should select a training environment that reflects as many of the learning points as possible and teach and assess accordingly. It is likely that some elements will arise during other lessons and these can be addressed as, and when, they occur.
2.	Encourage an unrushed driving style and the benefits of applying correct following distances. While the 2-second rule takes some practice to maintain, the benefits should be obvious to trainees. There will be <u>reductions in braking, a less stressful drive, more room for overtaking traffic and better visibility. Emphasise 'rugby field' distance and the consideration that if you don't plan to, or can't, overtake the vehicle ahead</u>

	there is no point in increasing the risk factors.	
3.	The system of vehicle control, yet again, provides a systematic approach to driving that is crucial in all open road conditions. This should form the basis for teaching many of the specific points contained within the lesson.	
4.	Misconceptions of speed relate to the belief that the faster you go, the sooner you will get there. Average speed is the distance the vehicle will travel in one hour. In reality, on NZ roads this is about 70-90 km/h depending on the route. Maximum legal speed is 100km/h but grades, corners, towns, intersections, traffic etc all influence the actual distance covered in that hour. If one vehicle travels at 110km/h and another at 100km/h, whenever they can, for one hour over the same route, the actual arrival times will differ very little, if at all, because of those delays. Apart from breaking the law, the faster vehicle will also have incurred higher fuel and maintenance costs and considerably increased the risk factors.	
5.	On sealed roads common hazards include faster traffic, slow traffic, road works, hills, corners, intersections. On unsealed roads common hazards include road dimensions, school buses, farm machinery, trucks, stock, bridges, grades etc.	
6.	Bright and low light conditions demand, for obvious reasons, different reactions by the driver. If the risk of sun strike exists the windscreen must be kept clean and sun visors and sunglasses used. In low light conditions, even in the middle of the day, consider the colour of the vehicle and encourage the trainee to switch on headlights to improve conspicuity.	
7.	This aspect of driving can be monotonous but distractions must be avoided as much as possible. These include eating, drinking, smoking, stereo use, cell phone use, texting and some external distractions. While some, like texting and cell phone use, must by law, be avoided at all times, others require a little thought as to the appropriate time and place.	
8.	Emphasise that the 3 key ingredients for safe driving on open roads in a vehicle are the maintenance of an appropriate speeds, correct following distances and early identification of potential hazards.	
9.	Quiz the trainee in relation to personal fatigue management strategies, both at home and at work, and look for any signs of tiredness.	
10.	The way in which other vehicles are driven on the highway should not influence the trainee. The fact is that many drivers do not operate competently in this environment, especially in relation to speed. Trainees should not feel pressured by other drivers to increase speed.	
11.	Commentary driving should be used by the trainer during teaching and considered an option for trainees to confirm observation skills.	
12.	Signs of stock movement might include warning signs, broken fences, road discolouration, open gates etc	
13.	Advance warning of unsealed roads might consist of signs, road discolouration, dust etc.	
14.	Monitor vehicle speed on unsealed roads as posted speed limits are often too high. Encourage speed that suits the driving conditions.	
15.	Clues to the presence of stock include signs, broken fences, time of day, open gates, road effluent etc.	
16.	In wet weather ensure trainee understands effects of heavy rain on roads and verges i.e. soft ground, pot holing, slips, flooding, corrugations etc.	
Faults	Symptom	Address/check
One handed steering.	Hand resting on gear shift lever or door handle.	Steering technique, over confidence.
Unreasonably slow.	Interference to other traffic. Well below speed limit.	Confidence. Is this lesson too soon?

Fails to recognise signs of stock movement.	Late braking.	Observation technique.
Fails to indicate intentions.	Reactions of other drivers. Inconveniences traffic.	Legal obligations.
Too fast.	Exceeds speed limit or safe speed for driving conditions.	Legal obligations. Overconfidence.
Follows too closely.	Too close to vehicle ahead.	2 and 4-second rules.
Fails to frequently check mirrors.	Unaware of movement of other traffic.	Confidence? Check every 5–10 seconds.
Fails to observe signs.	Late responses. Caught unawares.	Observation.
Fails to let following traffic past.	Does not use available opportunities to move left.	Observation. Attitude.
Not completely in correct lane.	Straddles fog or centre line.	Courtesy. Safety limitations.
Fails to indicate.	Responses from other drivers.	Legal obligations.
Excessively nervous.	Slow speeds. Inappropriate reactions to hazards.	Confidence. Is this lesson too soon?
Overconfidence.	Excessive speed. Demeanour. One handed steering.	
Lacks perception.	Not concentrating. Easily distracted. Late reactions to hazards.	Observation skills.
Poor cornering line or technique.	Excessive speed in corners. Crossing centre line. Braking in corner.	Cornering line and technique.
Dangerous overtaking.	Overtakes over yellow line. Fails to have 100m of clear visibility. Fails to indicate or check mirrors.	Legal obligations. Overconfidence?
Fails to recognise signs of stock movement.	Late reactions to stock hazards. Excessive speed in presence of clues.	Observation. Hazard action plan.. System of vehicle control.

## 18 Night driving

18	Night driving
Trainee name	
Location	
Vehicle details	
<p>For most New Zealanders, driving at night generally consists of trips of reasonably short duration and usually local. During holiday periods, the duration of these trips often extends over much longer distances and often over unfamiliar roads. Some drivers find they prefer these journeys at night, due to reduced traffic volumes, but there are risks associated with night driving that must be taken into account. Even a basic understanding of these risks and the use of the night driving aids provided on the road, is not always apparent with a large percentage of the driving population.</p>	
<p>References: Tranzqual ITO study guides US 17677 Demonstrate knowledge of safe night driving.</p>	
Performance	Drive safely and efficiently at night.
Standard	<p>Without inconveniencing other road users.</p> <p>While meeting all legal obligations.</p> <p>While maintaining vehicle control.</p> <p>Using the system of vehicle control.</p> <p>Applying the hazard action plan.</p> <p>While correctly interpreting night driving aids.</p>
Conditions	<p>In a light motor vehicle.</p> <p>On public roads including urban and on-highway.</p> <p>At night.</p>
Revision	Performance objective 9: Hazards and the system of vehicle control, 15 Town driving and 17 Rural/open road driving.

Explain- demonstrate - practice

1. Learning points (night driving)		Comments	Date completed	DI initials
a.	Checks all lights and indicators for operation, damage and cleanliness.			
b.	Checks all windows for cleanliness.			
c.	Meets all legal obligations in relation to the use of vehicle lights when driving at night.			
d.	Drives at a speed whereby the vehicle can be brought safely to a stop at any time.			
e.	Does not drive with interior lights switched on.			
f.	In the event of oncoming traffic not 'dipping' headlights, slows down and looks to left of road and does not retaliate by switching to high beam.			
g.	Explains colours and purposes of reflective road markers (cats eyes).			
h.	Explains and uses roadside markers and signs to identify corner directions and aid speed judgement.			
i.	Explains bridge abutment reflectors.			
j.	Maintains correct road position at all times.			
k.	Explains the effects of heavily laden cars and trailers on headlight beam.			
l.	Explains correct responses to feeling tired when driving at night.			
Comments				

## Instructors notes

1. While this is a night driving lesson the risks associated with low visibility driving conditions (winter driving, fog etc) should also be discussed.
2. Check all vehicle lighting prior to the lesson to be satisfied that everything operates correctly.
3. Discuss reflective driving aids in detail and expect the trainee to react to these in the correct manner. 'Cats eyes' consist of white (centreline), yellow (no passing), blue (fire hydrant) and red (left edge of road where this is deemed necessary). Bridge abutments are marked with white diagonal markers left side and yellow diagonal markers right side. Marker posts on left side of road have one white reflector and those on the right, where a left hand corner exists, have two yellow reflectors. The severity of a corner will be reflected in the distance between marker posts. The closer they are together, the tighter the corner. This is because drivers must be able to see, within their headlight beam, at least three marker posts at all times. Corner chevron boards, with speed advisory signs, should also be discussed.
4. Legal requirements for driving at night include low beam use and being able to stop within the distance of visible clear road (half this distance on roads without a centre line). 'Out driving' headlights is a common fault. It simply means that a driver will not be able to stop in time if a hazard appears in the headlight beam.
5. Discuss the advantages of following other vehicles at night, especially on unfamiliar roads, where their tail and brake lights can provide information on conditions ahead.
6. The use of high beam in retaliation to oncoming vehicles failing to 'dip' their lights is not acceptable. This will result in two drivers, who are closing at a very high combined speed, being unable to see.
7. Any tendency to cut corners at night must be eliminated. This usually results from a belief that there is no oncoming traffic because there is no visible sign of approaching headlights. Extending the available lane simply increases the likely risks.
8. Discuss the causes of fatigue when driving at night, especially monotony, boredom, vibration, noise and cab temperature and suggest ways of alleviating these, most particularly regular breaks and napping strategies.
9. While 100m of clear road must be visible throughout any overtaking manoeuvre, remember that it can take 300-400m of actual road to carry out the manoeuvre and therefore at least this much clear road must be available before committing. In low light conditions, unless the driver can see clearly 300-400m of clear road, the manoeuvre shouldn't take place. There might be oncoming traffic without its lights on.
10. In unlit areas, headlights should be on high beam unless low beam is required when meeting preceding or opposing vehicles. Low beam can be used to advantage at left and right hand bends and humps in the road.
11. Discourage the use of park lights when driving in low light conditions. Encourage 'all or nothing'. Park lights achieve nothing in relation to improving visibility but dash lights come on and drivers often forget to switch to headlights as light levels fall.
12. Explain reasons for not driving with interior lights on. (windscreen reflection, loss of exterior detail)
13. Explain the adjustment of the rear-vision to reduce glare when being followed by other vehicles with their lights on high beam.
14. Discuss likely states of other drivers at night and need for courtesy.

## Faults

## Symptom

## Address/check

Fails to turn on headlights early enough.

Other traffic with lights on.

Legal obligations, defensive driving.

Out driving headlights.	Driving too fast, late reactions to potential hazards.	Legal obligations, over confidence.
Lack of courtesy.	Fails to 'dip' headlights for oncoming traffic, pedestrians, cyclists etc.	Legal obligations, attitude.
Only looks at area directly in front of vehicle.	Erratic or late responses to potential hazards	Observation
Fails to use marker posts as guide.	Late braking in corners, excessive cornering speeds	Observation, signs

## 19 Reversing

19 Reversing	
Trainee name	
Location	
Vehicle details	
<p>A measure of an experienced driver is often their ability to reverse a vehicle in different directions.</p> <p>Although drivers spend little time going backwards, this is a necessary driving skill when manoeuvring a vehicle and one that takes a little practice to master. Once a trainee has gained confidence in general driving, introduce simple reversing manoeuvres at the conclusion of each training session so that the skills can develop progressively.</p>	
References: Tranzqual ITO study guides US 3470 Execute low speed manoeuvres in a light motor vehicle.	
Performance	Reverse a car in a straight line and through a turn.
Standard	<p>In a straight line for at least 20 metres.</p> <p>Through a 90 degree turn to the right.</p> <p>Through a 90 degree turn to the left.</p> <p>With no more than one correction for each manoeuvre.</p> <p>Without contact with any obstacle.</p> <p>Without stalling or over-revving the engine.</p> <p>Without undue stress to the vehicle.</p> <p>Meeting all legal requirements.</p>
Conditions	<p>In a light motor vehicle.</p> <p>On a driving range or public road.</p> <p>In daylight.</p>
Revision	N/A

Explain- demonstrate - practice

1. Learning points (straight back)		Comments	Date completed	DI initials
a.	If necessary checks planned reversing path on foot and identifies designated completion position			
b.	Checks any potential obstructions before reversing.			
c.	Turns on hazard lights.			
d.	Selects reverse.			
e.	Makes final visual checks ahead and behind for hazards (including shoulder check) and releases park brake.			
f.	Does not slip the clutch excessively. (manual)			
g.	Covers the brake with the right foot (automatic).			
h.	Gives way to pedestrians or other traffic if necessary.			
i.	Maintains observation to the rear while reversing.			
j.	Corrects steering in small increments and, if in doubt, pulls forward and realigns before starting again.			
k.	Reverses slowly and remains within any boundary limits.			
l.	Completes manoeuvre safely in designated position.			
2. Learning points (90 degrees right)		Comments	Date completed	DI initials
a.	Drives past turn and positions vehicle within any boundaries to minimise severity of turn.			

b.	Checks planned reversing path and identifies designated completion position and turn reference point.			
c.	Checks any potential obstructions before reversing.			
d.	Turns on hazard lights.			
e.	Selects reverse.			
f.	Makes final visual checks ahead and behind for hazards (including shoulder check) and releases park brake.			
g.	Gives way to pedestrians or other traffic if necessary.			
h.	Does not slip the clutch excessively. (manual)			
i.	Covers the brake with the right foot (automatic).			
j.	Maintains observation to rear while reversing.			
k.	Reverses slowly to and around turn reference point and then straightens up at completion of turn.			
l.	After turn corrects steering in small increments and, if in doubt, pulls forward and realigns before reversing again.			
m.	Remains within any boundary limits			
n.	Monitors front end swing.			
o.	Completes manoeuvre safely in designated position.			

3. Learning points (90 degrees left)		Comments	Date completed	DI initials
a.	Drives past turn and positions vehicle within boundaries to minimise severity of turn.			
b.	Checks planned reversing path and identifies designated completion position and turn reference point.			
c.	Checks any potential obstructions before reversing.			
d.	Turns on hazard lights.			
e.	Selects reverse.			
f.	Makes final visual checks ahead and behind for hazards (including shoulder check) and releases park brake.			
g.	Gives way to pedestrians or other traffic if necessary.			
h.	Does not slip the clutch excessively. (manual)			
i.	Covers the brake with the right foot (automatic).			
j.	Maintains observation to rear while reversing.			
k.	Reverses slowly to and around turn reference point and then straightens up at completion of turn.			
l.	After turn corrects steering in small increments and, if in doubt, pulls forward and realigns before reversing again.			
m.	Remains within any boundary limits			
n.	Monitors front end swing.			

- |    |                                                    |
|----|----------------------------------------------------|
| o. | Completes manoeuvre safely in designated position. |
|----|----------------------------------------------------|

### Comments

### Instructors notes

- |     |                                                                                                                                                                                                                                                                                                                                                                                                                                                       |
|-----|-------------------------------------------------------------------------------------------------------------------------------------------------------------------------------------------------------------------------------------------------------------------------------------------------------------------------------------------------------------------------------------------------------------------------------------------------------|
| 1.  | Explain to trainees that there is no rule that states a reversing manoeuvre must be completed on the first attempt. The instructor's aim should be to achieve a trainee standard that allows him / her to complete the manoeuvres with no more than one realignment but the emphasis must be on completing it safely.                                                                                                                                 |
| 2.  | Encourage practice.                                                                                                                                                                                                                                                                                                                                                                                                                                   |
| 3.  | Steering responses change when a vehicle is reversing. Because the steering axle is now at the 'rear' of the vehicle that end is much more responsive to steering input while the leading axle, the rear axle, is far less responsive. This demands frequent small steering corrections rather than infrequent large ones.                                                                                                                            |
| 4.  | The position of the hands on the steering wheel is not an issue with this lesson. Trainees are most likely to steer with one hand on top of the wheel and change hands frequently.                                                                                                                                                                                                                                                                    |
| 5.  | Explain the tyre damage issues that can result from kerb strikes.                                                                                                                                                                                                                                                                                                                                                                                     |
| 6.  | Encourage reversing off a road rather than on to it. The driver has a better awareness of prevailing conditions when backing off a road than he would trying to reverse blind onto it.                                                                                                                                                                                                                                                                |
| 7.  | Encourage reversing to the right so that observation is simplified.                                                                                                                                                                                                                                                                                                                                                                                   |
| 8.  | Use driving ranges, with cones or gates, at least for initial lessons. This minimises interference and develops trainee confidence.<br>For safety reasons when any reverse turn manoeuvre is performed on a road ensure that it is performed into a suitable entrance way rather than reversing back through an intersection.                                                                                                                         |
| 9.  | Remind trainees that, often, the point of contact with obstacles during reversing manoeuvres, is the front corners of the car. This part of the vehicle must be included in the ongoing search pattern during reversing.                                                                                                                                                                                                                              |
| 10. | Explain the vehicle reference point (the point where the vehicle will pivot during reversing) is the rear axle.                                                                                                                                                                                                                                                                                                                                       |
| 11. | When the vehicle is moving back on a straight course, to enter a turning on the left a slight amount of right lock may need to be applied to move the rear of the vehicle away from the kerb. Left lock must then be progressively applied to bring the rear of the vehicle into the side turning. The left steering lock must then be progressively taken off by turning the steering wheel to the right to enable a straight course to be achieved. |
| 12. | When reversing into a turning on the right hand side the steering movements are opposite to those described above.                                                                                                                                                                                                                                                                                                                                    |
| 13. | The greater the speed, the more difficult it is to steer accurately. Anytime reversing is practised, it must be done at a slow speed with delicate use of the clutch, accelerator and brake pedals.                                                                                                                                                                                                                                                   |

Faults	Symptom	Address/check
Poor accelerator and clutch control.	Reverses 'jerkily', reverses too quickly.	Practice. Gear selection.
Fails to use key reference points.	Turns too soon, turns too late, strikes obstacle. Erratic steering	Practice. Judgement
Poor steering control.	Strikes boundaries or obstacles. Excessive realignments	Practice steering control
Fails to stop in designated position.	Strikes boundaries or obstacles.	Mirror settings. Judgement

## 20 Emergency stops

20	Emergency stops
Trainee name	
Location	
Vehicle details	
Braking system	
<p>Modern technology has improved safety standards for all vehicles. One of the advancements made in this respect relates to braking systems and the introduction of anti-lock brakes (ABS). This technology offers a specific advantage (avoidance steering) in emergency stopping situations, provided the driver understands the operating principle and correct driver responses. This lesson is designed to introduce new drivers to ABS and to two alternative braking techniques that can be used on any vehicle to minimise the risks of wheel lock up and any subsequent loss of steering or directional control.</p>	
<p>References: Tranzqual ITO study guides US 3469 Apply control in driving a light motor vehicle.</p>	
Performance	<p>Demonstrate progressive and cadence braking techniques.</p> <p>Demonstrate correct use of ABS. (where fitted).</p>
Standard	<p>While maintaining full steering control of the vehicle.</p> <p>Stopping in a straight line.</p> <p>At a speed of 60km/h.</p> <p>Without contact with any obstacle.</p> <p>Without stalling the engine.</p>
Conditions	<p>In a light motor vehicle.</p> <p>On a driving range or closed road.</p> <p>In daylight.</p> <p>In repeated trials.</p>
Revision	N/A

Explain- demonstrate - practice

1. Learning points (progressive braking)		Comments	Date completed	DI initials
a.	Initially applies foot brake firmly.			
b.	Progressively applies brake pedal pressure as vehicle speed decreases.			
c.	Looks ahead, not at the ground in front of the vehicle.			
d.	Maintains two handed steering and avoids any obstacles.			
e.	Depresses clutch pedal (manual) just before stopping to prevent stalling.			
f.	Stops short of any designated obstacle without excessive wheel lock up.			
2. Learning points (cadence braking), also known as pulse braking		Comments	Date completed	DI initials
a.	Depresses clutch pedal (manual) to the floor and holds it there.			
b.	Stabs brake pedal repeatedly to apply and release brakes.			
c.	Looks ahead, not at the ground in front of the vehicle.			
d.	Maintains two handed steering and steers around any hazards.			
e.	Stops short of any designated obstacle without excessive wheel lock up.			
3. Learning points (ABS)		Comments	Date completed	DI initials
a.	Explains basic operation and key advantages of ABS.			

b.	Pushes both clutch and brake pedal to the floor and leaves them there.
c.	Looks ahead, not at the ground in front of the vehicle.
d.	Maintains two handed steering and steers around any hazards.
e.	Stops short of any designated obstacles.

Comments

Instructors notes

1.	While the key teaching points for this lesson are progressive and cadence braking, cover the practical use of ABS if the training vehicle has it. Use every opportunity to make sure that trainees understand how to use the system properly and emphasise the steering response.
2.	If the training vehicle does not have ABS explain the technology anyway and the advantages that accrue from it. Remember, the main advantage is the ability to continue steering to avoid hazards.
3.	Select the training ground carefully and avoid the use of public roads. Use cones as braking markers and obstacles and slowly increase speed as trainee confidence grows.
4.	Depressing the clutch prevents momentary stalling of the drive wheels, which can happen on slippery surfaces, even with ABS. If this occurs the engine will stall and power steering will be lost.
5.	Expect trainees to be quite hesitant about stabbing the brake pedal during cadence braking and allow time for confidence to develop. The final results will surprise the trainee.
6.	Emphasise that drivers must not increase road speed or cornering speed, or reduce following distances, just because their vehicle is equipped with ABS. The normal safe driving practices still apply.
7.	Emphasise that emergency stops require the driver only to brake. If there is time to downshift it isn't an emergency!
8.	ABS operates when electronic sensors detect a wheel about to lock up and repeatedly releases the brake and reapplies it automatically until the risk has passed. The driver will sense the ABS operating through pulsing at the brake pedal.

Faults	Symptom	Address/check
In progressive braking, applies too much initial pressure.	Wheels lock up.	Practice. Confidence.
In progressive braking, applies too little pressure.	Vehicle does not slow quickly enough for emergency situation.	Practice. Nervousness.

In cadence braking, stabs brake pedal too lightly.	Vehicle does not slow quickly.	Practice. Explain need to maximise braking effort..
In cadence braking stabs brake pedal too slowly.	Vehicle lurches.	Practice. Confidence.
Does not depress clutch pedal.	Vehicle stalls.	Practice.
Does not look far enough ahead during braking.	Vehicle begins to step out of line.	Identify point of visual reference.
Does not maintain two handed steering.	One hand on gear lever. Poor steering avoidance.	Over confidence.
Anticipates instructions.	Begins braking too early.	Ensure trainee understands sequence and instructions. Practice.
Fixated.	Fails to steer to avoid.	Confidence. Practice

## 21 Parallel parking

21	Parallel parking
Trainee name	
Location	
Vehicle details	
<p>Of all the manoeuvres a driver has to perform, the one that obviously causes the most problems is parallel parking. On a daily basis in town or city driving we see drivers who fail to start the manoeuvre properly or who, even more frequently, fail to complete it successfully. Many drivers will try to avoid the exercise altogether and in doing so, might save some embarrassment but also miss good parking opportunities. There is no doubt that the drivers of larger cars are at a disadvantage in this regard, but the basics of parallel parking are the same for any vehicle. The first step in the process is to ensure that the car is not longer than the parking space and the final step is to ensure that once parked it is in the space and not parked on the road!</p>	
<p>References: Tranzqual ITO study guides US 3470 Execute low speed manoeuvres in a light motor vehicle.</p>	
Performance	Parallel park at a kerb between two cars.
Standard	<p>With no more than one forward and one reversing motion.</p> <p>Without contact with any obstacle including the kerb.</p> <p>Without stalling or over-revving the engine.</p> <p>Without inconveniencing other road users.</p> <p>Meeting all legal requirements.</p> <p>Centrally within the parking space no more than 30cm from the kerb.</p>
Conditions	<p>In a light motor vehicle.</p> <p>On a public road</p> <p>With other vehicles in front and behind.</p> <p>In repeated trials.</p> <p>In daylight.</p>
Revision	Performance objective 19: Reversing

## Explain- demonstrate - practice

1. Learning points (parallel park)		Comments	Date completed	DI initials
a.	Identifies suitable parking space			
b.	Signals left			
c.	Positions vehicle alongside the vehicle in front of the parking space leaving a space of about one metre between the two.			
d.	Searches for hazards in both directions using mirrors and head checks to both sides.			
e.	Selects reverse.			
f.	When safe to move, reverses and steers slowly to the left into the space until vehicle is at a 45 degree angle.			
g.	Once front door is in line with other vehicle's rear bumper, turns the steering wheel to the right until vehicle is parallel with the kerb.			
h.	Moves vehicle forward until central in the parking space.			
i.	Final position is no more than 30cm from the kerb.			
j.	Places gear shift lever into neutral or 'Park' and applies the hand brake.			
2. Learning points (exiting a parallel park)		Comments	Date completed	DI initials
a.	Signals right for at least three seconds before moving out of parking space.			
b.	Checks mirrors and conducts head check over shoulder into blind spots.			
c.	Selects reverse gear.			

d.	Releases hand brake.
e.	Reverses slowly until there is sufficient room ahead of the vehicle to turn out onto the road.
f.	Selects first gear or 'Drive' and conducts mirror and head checks again.
g.	Moves forward and steers out onto the road avoiding contact with the car ahead.
h.	Cancel signal and accelerates to road speed.

### Comments

### Instructors notes

1.	While car parking spaces are designed to allow small, medium and large cars to park safely, it is a fact that the larger the vehicle is the more difficult it will be to park, especially between other large cars. If a parking space is partially blocked by another vehicle, which happens frequently, find another park rather than deal with a very limited space.
2.	ALWAYS reverse into parallel parks. DO NOT allow trainees to try and drive forwards into a space unless there is more than one space available.
3.	Steering responses change when a vehicle is reversing. Because the steering axle is now at the 'rear' of the vehicle that end is much more responsive to steering input while the leading axle, the rear axle, is far less responsive. This demands small steering corrections rather than large ones.
4.	The position of the hands on the steering wheel is not an issue with this lesson. Trainees are most likely to steer with one hand on top of the wheel.
5.	Explain the tyre damage issues that can result from kerb strikes.
6.	If the trainee cannot park the vehicle within 300 mm of the kerb after 2 minutes or makes so many errors, that it is obvious that they cannot succeed, discontinue the lesson for the time being,
7.	If parking outside shops, show the trainee how reflections off shop windows can assist with spatial judgement.
8.	Use driving ranges, with cones or gates, at least for initial lessons. This minimises interference and develops trainee confidence.
9.	<u>Remind trainees that, often, the point of contact with obstacles during parking manoeuvres, is the front corners of the car. This part of the vehicle must be included in the ongoing search pattern during parking.</u>
10.	Explain the vehicle reference point (the point where the vehicle will pivot during reversing) is the inside rear axle.
11.	The greater the speed, the more difficult it is to park safely and accurately. Anytime reversing occurs it must be done at low speed with delicate use of the clutch, accelerator and brake pedals.

12.	Encourage practice.	
Faults	Symptom	Address/check
Poor accelerator and clutch control.	Reverses 'jerkily', reverses too quickly.	Practice. Gear selection.
Fails to use key reference points.	Turns too soon, turns too late, strikes obstacle. Erratic steering	Practice. Judgement
Poor steering control.	Strikes kerb or obstacles. Excessive realignments	Practice steering control
Fails to stop in designated position.	Strikes boundaries or obstacles. More than 30cm from kerb.	Judgement. Practice
Starts from wrong road position.	Too far away from other vehicle. Too far forward. Too far back.	Practice.
Fails to identify potential hazards.	Inadequate mirror use or head checks.	Observation.
Fails to signal.	Position of other vehicles. Other driver responses.	Legal requirements.
Parks illegally.	Parked over vehicle entrance, bus stop, too close to intersection or pedestrian crossing.	Legal requirements.

## 22 U-turns and three-point turns

22	U-turns and three-point turns
Trainee name	
Location	
Vehicle details	
<p>Eventually, every driver has to turn and reverse their route. Most often the quickest and simplest option, depending on road width, is to make a u-turn or three-point turn. There are obvious risks involved with these manoeuvres and, unfortunately, a large number of crashes, often serious, result from them. Many motorcycle accidents, for example, occur as a result of a car driver failing to check behind or to the side before turning. While the steps involved are very simple it is vital that everything that has to be done is done consistently well. For this reason, one of these manoeuvres may be included in the Class 1 driver licence tests.</p>	
<p>References: Tranzqual ITO study guides US 3470 Execute low speed manoeuvres in a light motor vehicle.</p>	
Performance	Make a u-turn and a three-point turn
Standard	<p>Without stalling or over-revving the engine.</p> <p>Without inconveniencing other road users.</p> <p>Meeting all legal requirements.</p> <p>Without striking the kerb or any obstacle.</p> <p>Without reversing (u-turn) and with only one reversing manoeuvre (three-point turn).</p>
Conditions	<p>In a light motor vehicle.</p> <p>On a public road</p> <p>In repeated trials.</p> <p>In daylight.</p>
Revision	Performance objective 21: Parallel parking

Explain- demonstrate - practice

1. Learning points (u-turn)		Comments	Date completed	DI initials
a.	Identifies a suitable place in which to make the turn.			
b.	Signals left and pulls over as close as possible to the left side of the road.			
c.	Searches ahead and behind using mirrors.			
d.	Selects first gear.			
e.	Signals a right turn.			
f.	Checks ahead and behind again (including over shoulder check into blind spots) to ensure the road is clear.			
g.	Moves off slowly and steers right until the car is on the opposite side of the road facing in the opposite direction.			
h.	Keeps left and checks mirrors again.			
i.	Cancels signal and accelerates to road speed.			
2. Learning points (three-point turn)		Comments	Date completed	DI initials
a.	Identifies a suitable place in which to make the turn.			
b.	Signals left and pulls over as close as possible to the left side of the road.			
c.	Searches ahead and behind using mirrors.			
d.	Selects first gear.			

e.	Signals a right turn.
f.	Checks ahead and behind again (including over shoulder check into blind spots) to ensure the road is clear.
g.	Moves off slowly and steers right until the car is at right angles facing the opposite side of the road.
h.	Stops before the front wheels strike the kerb and applies the handbrake.
i.	Selects reverse gear.
j.	Checks all around to ensure road is still clear.
k.	Releases the hand brake and reverses slowly immediately turning the steering wheel to the left until the vehicle is pointing in the new direction..
l.	Stops and selects first gear.
m.	Checks road is still clear and moves off steering the vehicle to the correct position on the left side of the road and accelerating to road speed.

Comments

Instructors notes	
1.	These are quite simple manoeuvres, frequently done wrong. Explain the risks of failing to ensure the road is clear and the subsequent need to perform the manoeuvres in a location that has good visibility in both directions.
2.	The use of the hand brake is not compulsory provided the vehicle does not roll forwards or backwards.
3.	Remind trainees that U turns cannot be made where signs prohibit the turns.
4.	The position of the hands on the steering wheel is not an issue with this lesson. Trainees might use hand over hand steering.
5.	Explain the tyre damage issues that can result from kerb strikes.

6.	If the trainee cannot complete either turn after a few minutes or makes so many errors, that it is obvious that they cannot succeed, discontinue the lesson for the time being.	
7.	Explain reasons for steering only when the car is moving.	
8.	Use driving ranges, with cones or gates, if this helps develop confidence.	
9.	Emphasise importance of observation skills and gap selection.	
10.	Make sure motorcyclists, cyclists and pedestrians are all included, and considered, in the search pattern.	
11.	Encourage practice and incorporate the turns frequently into training and coaching.	
Faults	Symptom	Address/check
Poor accelerator and clutch control.	Manoeuvres 'jerky' or too fast.	Practice. Accelerator, brake, clutch coordination.
Poor steering control.	Strikes kerb or obstacles. Excessive realignments	Practice steering control
Starts from wrong road position.	Too far away from kerb. Insufficient room for U turn.	Practice.
Fails to identify other traffic.	Inadequate mirror use or head checks.	Observation.
Fails to signal.	Position of other vehicles. Other driver responses.	Legal requirements.

## Section 7: Blank road layouts

